

Capture

HIGHLIGHTS OF NEW FEATURES

1.	New Capture Desktop - Experiment Mode	4
2.	New Capture Desk Top - Recipe Mode	5
3.	Export of Raw Data	6
4.	ESCA Control Panel – Replacement for A Quick	8
5.	Motor Control Panel – GPIB Interface	9
6.	Motor Control Panel – Ethernet Interface	10
7.	Position Table	11

TOPICAL DESCRIPTION OF SOFTWARE

In the following sections, topics of operation are discussed in alphabetical order

1.	Calibration and Setup	
	a. Introduction to applet	13
	b. Outline of steps	14
	c. Hardware configuration	14
	d. Software configuration	15
	e. Establishing starting calibration values	17
	f. Run DAC to calibrate BE span	19
	g. Run Detector Width Calibration	20
	h. Run V1 curves	21
	i. Signature correction	22
2.	Database Functions	25
	a. Creating a new database	26
	b. Get recipes from another database	27
3.	Depth Profiles	29
	a. Creating a new database	26
	b. Get recipes from another database	27
3.	Depth Profiles	29
	a. Open the depth profile table generator	29
4.	ESCA Control Panel	31
	a. Unscanned mode	31
	b. Scanned Mode	32
	c. Quick survey	33
5.	Experiment Names as part of the database structure.	35

6.	Graphics controls	
	a. Chart editor	36
	b. User Preferences	38
	c. Print Utility	39
	d. Spectrum color	41
	e. Clipboard	41
7.	Motion Control	
	a. Angle Resolve and tilt stage setup	42
	b. Enable/Disable Buttons	47
	c. Home controls	47
	d. Mode control of the Joystick buttons (6K4)	48
	e. Panic Button	50
	f. Position Table Setup	51
	g. Rotation	54
	h. System Configuration (GPIB, 6K4, disable axes)	55
	i. Units, coordinates	56
	j. Velocity Setup (GPIB with 2100 Indexers)	57
8.	MRS Tables	58
	a. Construction by selecting and editing Functions	59
	b. Templates	62
	c. Run Controls	63

Software conventions

1. When text boxes are White they will accept data entry.
2. When text boxes are Blue they are read only.
1. when text boxes are white they will accept data entry.
2. When text boxes are Blue they are read only.
3. Buttons or labels that are Red indicate something is turned off.
4. Buttons that are Green indicate something is turned on.
5. Buttons that are Yellow indicate something is turned on but temporarily not in a useable state.

New Capture Desktop - Experiment Mode

The screenshot shows the ESCA 2000 G software interface in Experiment Mode. The interface includes a menu bar (File, Help, Settings, Exit), a toolbar, and several main panels. A callout box labeled "Experiment Mode" points to the top of the window. A callout box labeled "Experiment Tree" points to the left sidebar containing a list of experiments such as "Iron from SS", "Multi scan Au", and "Phosphor 2". A callout box labeled "MRS table" points to the central table with columns for Function, LBE, Window/Width, Spot Size, Scans/Time, Rest#, and EV/Step. A callout box labeled "Clear MRS table" points to a "Clear" button on the right side of the MRS table. Below the MRS table is a plot showing a spectrum with counts on the y-axis (0 to 2.4K) and energy on the x-axis (550 to 0). To the right of the plot is a metadata section with fields for Proj Name, Exp Name, Exp Desc, and Analyst, along with a table for scan parameters.

Scan	Visible	Xoffset	Yoffset
Survey		0	0
C1s		0	0

A Quick is no longer available. There is no requirement to create a recipe. When in Experiment Mode, simply edit the MRS table to create a parameter set for the next data acquisition. The MRS table will be stored with the data.

The Experiment Tree shows the past experiments. Selecting an experiment will recall the stored MRS table. You have four options:

The Experiment Tree shows the past experiments. Selecting an experiment will recall the stored MRS table. You have four options:

1. Run MRS table with a new Project/Experiment name.
2. Modify MRS table and run with new Project/Experiment name.
3. Overwrite recalled Experiment.
4. Save MRS table as a Recipe. To save MRS as a recipe use File menu, Save As – Recipe.

The Clear button provides a quick way to start a new MRS table. Don't worry about the existing MRS table. If it has been run it is saved. All MRS tables saved with experiments have the Recipe name "None".

New Capture Desk Top - Recipe Mode



1. Save Recipe. Requires Recipe Mode. Saves current state of MRS table to active recipe. Save Icon causes same action.

2. Save As – Recipe creates a new Category/Recipe. May be used from Experiment Mode.

3. In Recipe Mode changes to MRS are NOT saved unless the Save Recipe or Save Icon is used. Recipes should not be changed after they are established. This can cause unexpected results in linked Position Tab

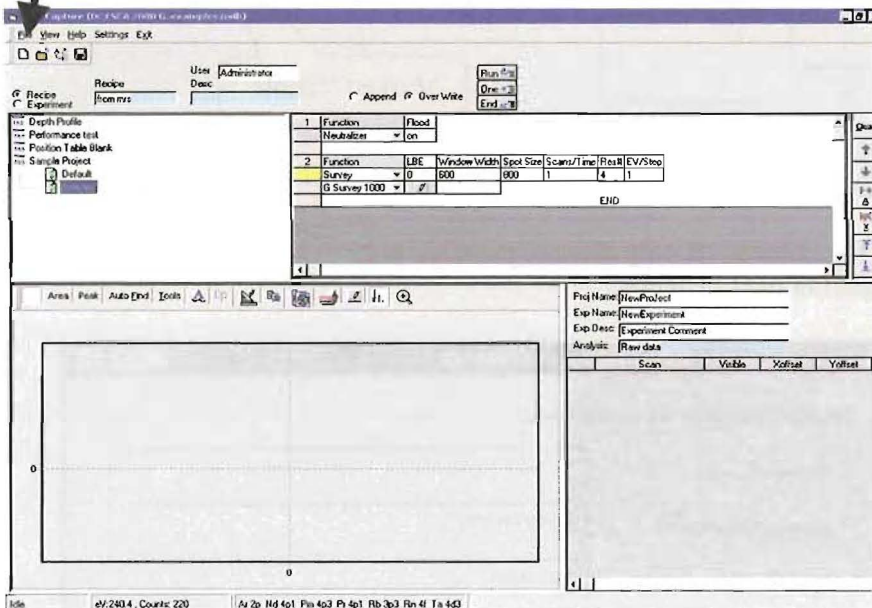

To create a new recipe just Clear the current MRS table and then compose a new table.

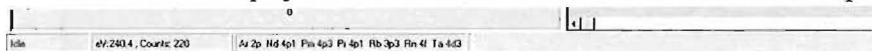

To create a new recipe just Clear the current MRS table and then compose a new table. Then to turn the MRS table into a Recipe:

1. Go to File menu and select Save AS - Recipe
2. File out the Category name, Recipe name and description.
3. You can browse to an existing Category and then edit the Recipe. This provides a fast way to add Recipes in a sequence.

Export of Raw Data

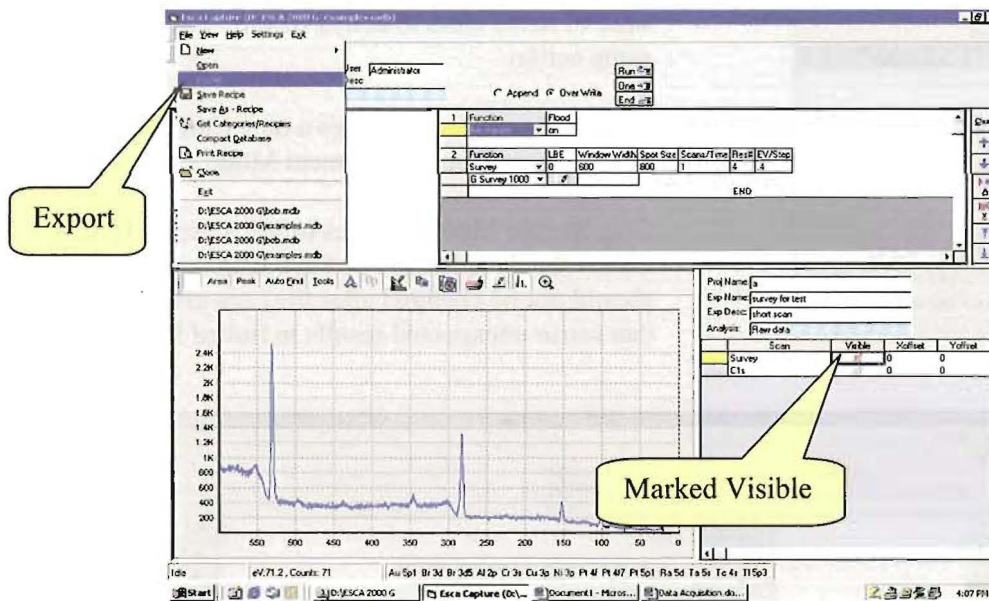

1. Select an Experiment. If only some regions are to be exported mark them visible.
2. Select Export in the File menu.

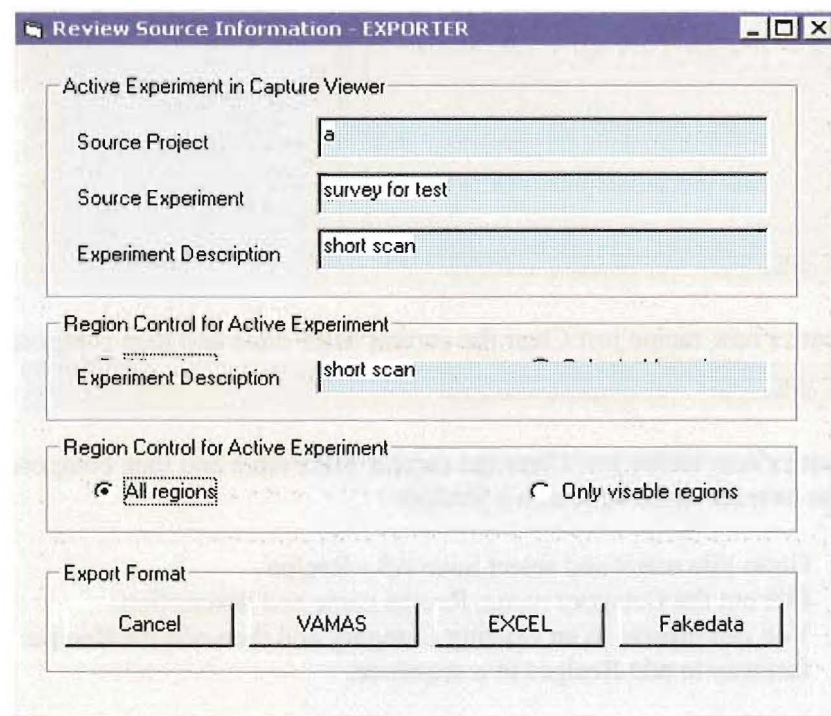

3. Choose All regions or Only Visible regions. Select type of export.

Export of Raw Data – Cont.

The VAMAS export is an ASCII file readable by any text editor. The arrangement of information follows the international standard for Surface Science Data. All region of the MRS can be included in one VAMAS file. The VAMAS file can hold a complete depth profile. This is a very flexible and well-defined export file.

To use the Excel export, Excel must be available on the computer running the ESCA application. It does not need to be running. The export will open an Excel notebook, fill header cells with instrument parameters and provide a column of numbers representing the spectrum data. A crude graph is also created for quick review. There will be one page per spectrum. All spectra for a MRS table or just the regions marked visible can be included. A depth profile can be exported.

Fakedata.txt is an internal text file used for demonstration purposes. Any spectra can be converted to a fakedata.txt file and then used by the Demo program to simulate the collection of data. This can be convenient for training and remote investigation of the program operation.

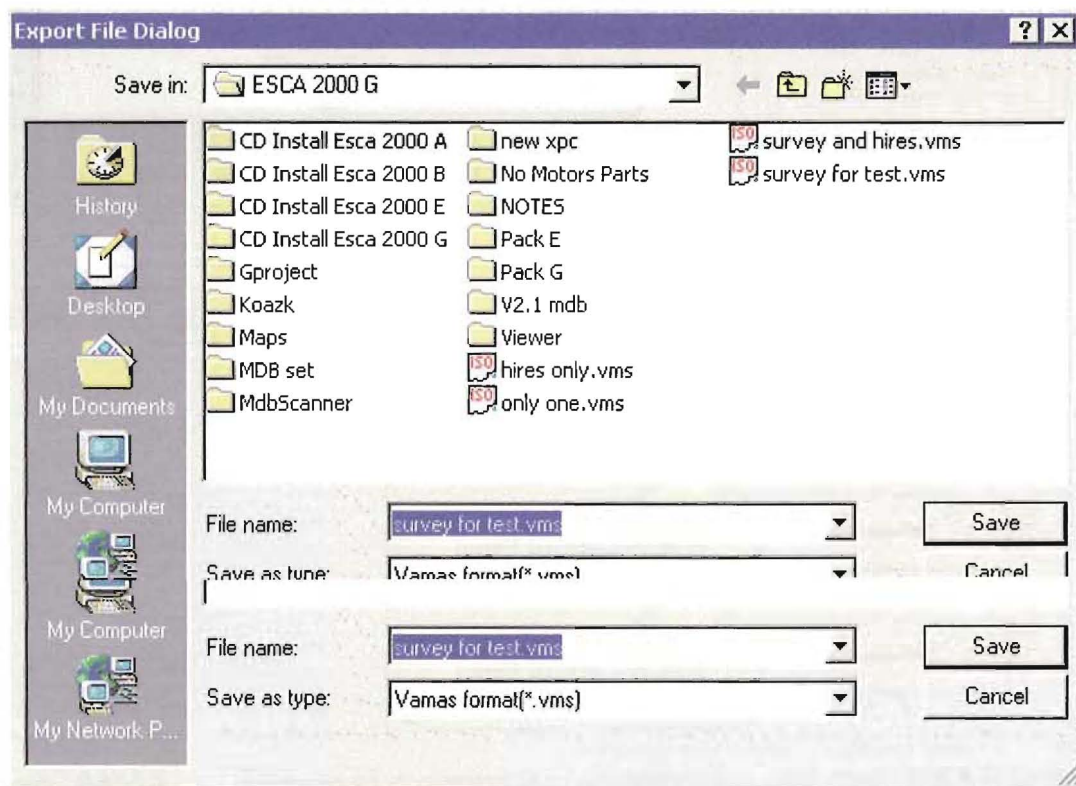

The Export File Dialog is used with the VAMAS export. This is a standard Windows dialog. File storage for the Excel is handled out of the Excel program.

ESCA Control Panel – Replacement for A Quick

The screenshot shows the ESCA 2000 software interface. The 'View' menu is open, highlighting the 'ESCA Control Pnl' option. A yellow callout bubble points to this menu item with the text 'View Menu item, ESCA Control Pnl'. Another yellow callout bubble points to the 'ESCA Control Panel' window, which is titled 'ESCA Control Panel' and contains various control options for the spectrometer. A third yellow callout bubble points to the 'ESCA Control Panel view screen' area, which displays three stacked plots: a top plot showing a flat line at 0.0, a middle plot showing a noisy signal between 200 and 600, and a bottom plot showing a similar signal between 350 and 550. The status bar at the bottom indicates 'eV:442.4, Count: 364' and 'Bi 4d5 Ge a In 3d In 3d5 Re 4p3 To 3p1'.

View Menu item, ESCA Control Pnl

ESCA Control Panel

ESCA Control Panel

ESCA Control Panel view screen

The ESCA control panel is used for direct access to the spectrometer. You may change a setup condition and hit start even if a scan is in progress. The scan will automatically abort and restart. The Time/Step can be changed. If scanned is checked "Capture T" provides an estimate of the total capture time. The top row of controls will change the state of the ESCA when the control is clicked. The eight controls in the frame change state when the Start button or Enter Key is hit.

Motor Control Panel – GPIB Interface

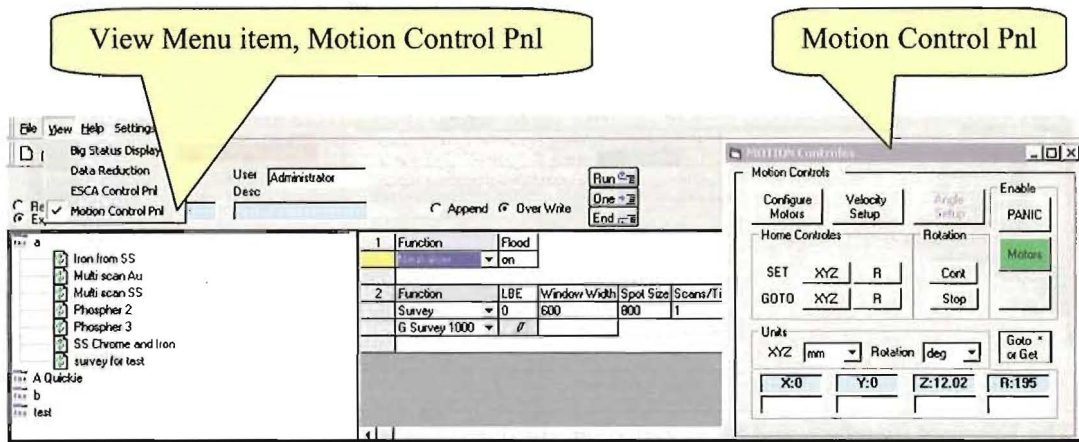

1. Configure Motors:
 - a. Set type of motion control interface
 - b. Turn on/off individual axes.
2. Velocity Setup:
 - a. Set velocity of individual axes.
3. Home Controls
 - a. Set XYZ: Set current XYZ position 0,0,0
 - b. Set R: Set current R position 0
 - c. GOTO XYZ: Return to XYZ = 0,0,0
 - d. GOTO R: Return to R = 0 or 360
4. Rotation
 - a. Cont. Starts continuous rotation.
 - b. Stop Stops continuous rotation.
5. Panic Stops all motion and disables Motors.
6. Motors: Green means Enabled. Yellow means computer control. Red means Disabled.
7. Units:
 - a. XYZ : Set scale system to MM, Inches or number of steps.
 - b. Rotation: Set scale system to Deg, number of steps or tilt.
 - c. GOTO or Get * IF number is present in any white box then motors will move to position. If all boxes empty then computer will get current position. This is useful after Joystick movement of stage. * denotes that the Enter Key will produce this function if form is active.

Motor Control Panel – Ethernet Interface

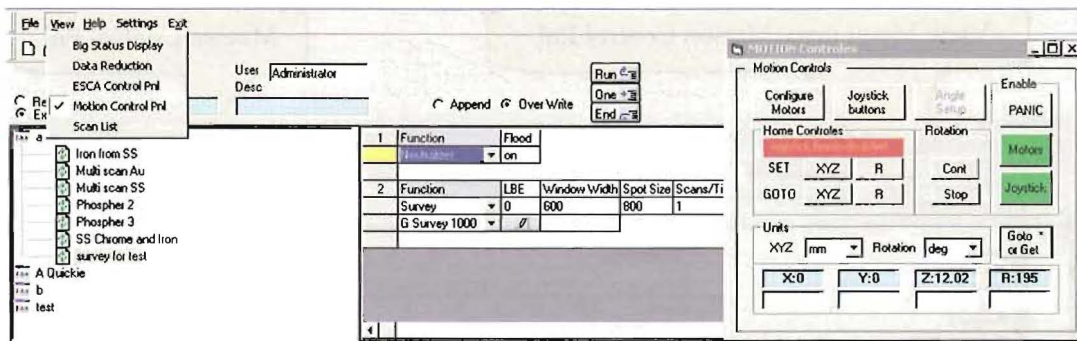

The Ethernet interface and 6K4 controller allow for use of a USB Joystick. The Joystick button has three states:

- Green – Enabled
- Yellow – Motion under computer control
- Red – Disabled. This secures the motion system from accidental input while running a position table.

The button labeled “Joystick Buttons” controls the state of the remote buttons located of the joystick. Two buttons can be set to update the home positions or to cause forward or back stepping through the position table. The state is toggled between these two functions by this button. The message box in red with yellow letters describes the current state.

It will be noticed that one additional difference between the GPIB/2100 Indexer system and the Ethernet/6K4 system is the speed of operation. The Ethernet communication provides real time position information during the motion of the stage. The blue read only boxes post the position in real time.

provides real time position information during the motion of the stage. The blue read only boxes post the position in real time.

Page 51 for Position Table Setup

Position Table

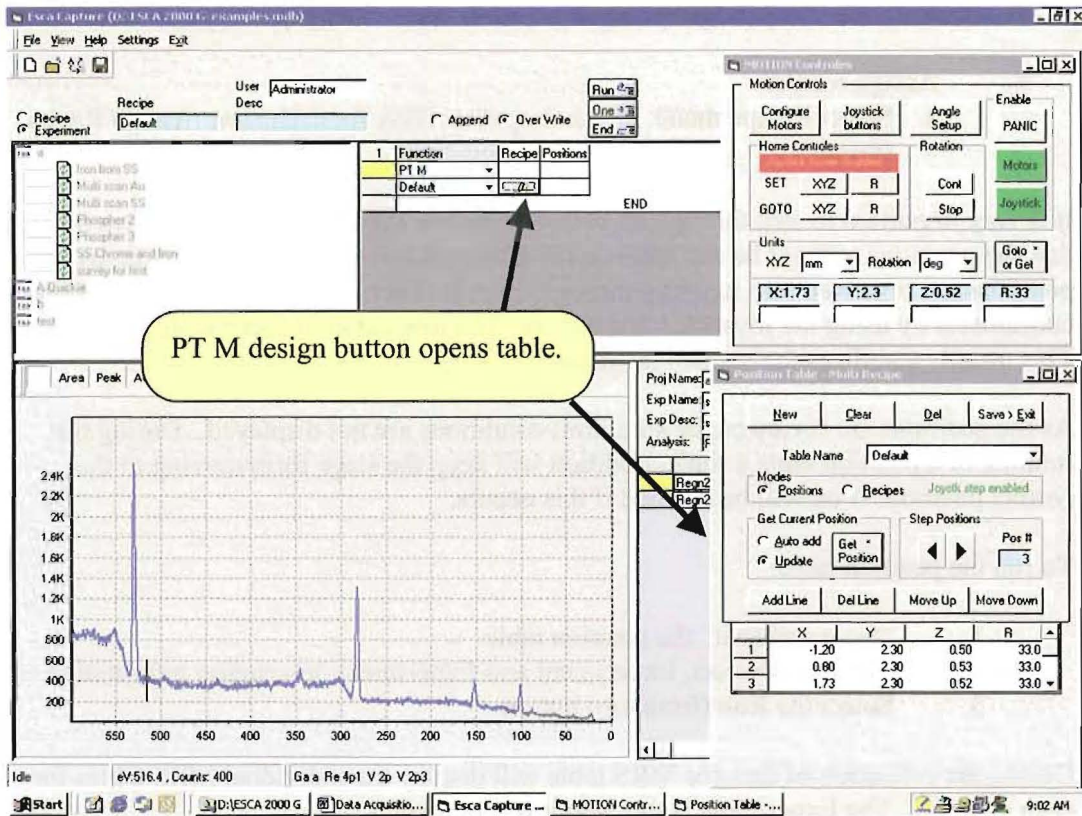

Steps to set up Position Table:

1. Tool Bar > View > Motion Control Pnl
2. MRS Table function > PT M > Table Name (Default in this case) > Design Button.
3. Table options:
 - a. Create a new table, Clear the displayed table, Delete the displayed table or Save and run table.
3. Table options:
 - a. Create a new table, Clear the displayed table, Delete the displayed table or Save and run table.
 - b. Create a table of positions:
 - i. Learn positions using joystick.
 - ii. Move to positions using control panel, then transfer to table.
 - iii. Numerical entry directly to table.
 - c. Table Row controls
 - i. Add row
 - ii. Delete row
 - iii. Move row up
 - iv. Move row down

4. Review of positions.
 - a. Select “numbered” buttons at end of Row. Stage will move to position.
 - b. Select Step forward/Step Back buttons on Table Form.
 - c. Select Step forward/Step Back buttons on USB joystick (6K4 controller).

5. Assign recipes
 - a. Select Recipe mode. Click drop down box for each row. Assign Recipe from list.

It is very important to step through all positions before running a table. We have noticed that the positions will not be the same on the first pass after learning. However, as the positions are reviewed by stepping through them in order, it is easy to refine the stored coordinates by using the joystick learn button. The row cursor automatically follows. This usually stabilizes the learned positions.

As the positions are reviewed, be sure limit conditions are not displayed. During the running of a position table a limit condition will keep the stage from moving to the correct position. You will be notified if this occurs.

To run the position table:

1. “Save and Exit” the position table
2. Enter the Project, Experiment and Experiment description information.
3. Select the Run (from top) button

During the collection of data the MRS table will display the individual MRS tables for each position. The Experiment Name window will display:

Your Experiment Name: POS X where X is the position number.

For more details on Position tables See “Position Table Setup” pg 51

Calibration and Setup – Outline of steps

It is very helpful if the calibration parameter values, from the previous software, are available. IF you are upgrading from ESCAVB without a change of operating system these steps are not required. If a new operating system was installed then proceed with calibration.

1. Configure the registry entries for the ESCA system hardware.
2. Configure calibration parameter values that were used in previous software. If these are not available then develop a rough set of starting values.
3. Run DAC to calibrate the span of the BE scale.
4. Run Detector Width to calibrate the detector and set the absolute BE.
5. If the ESCA Instrument has a V1 (lens focus voltage) supply in the Spectrometer Power Supply that is digitally controlled then run V1 calibration curves.
6. Return to the main program and set up Signature correction.

Calibration and Setup – Hardware configuration

Use the main tool bar and select the Settings menu. Select Capture Settings.

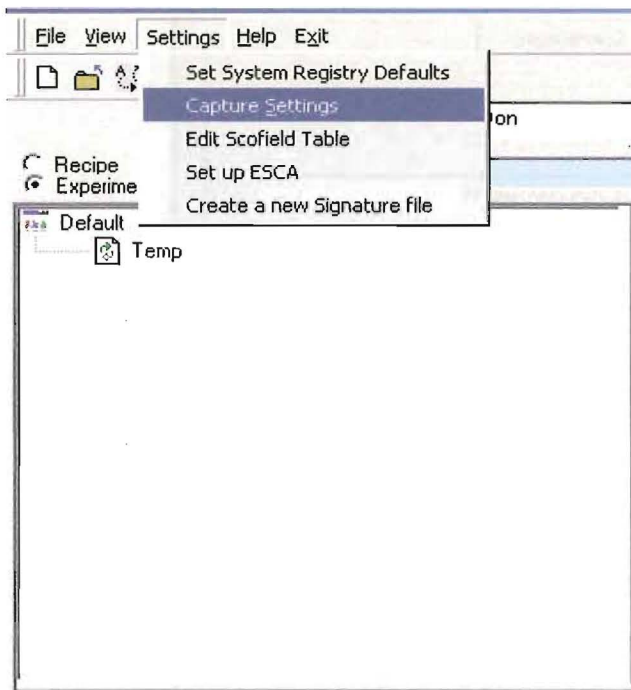

Calibration and Setup – Hardware configuration - Detector

Select the Detector Tab in the Dialog. If a valid signature file is available then check the Signature Correction ON box. If this is a new installation then see Signature Correction section below.

If the “Signature file could not be loaded” message was displayed during the startup of the program check the Signature File Path. The sig.txt file, that holds a valid signature, must be available. The installation will make a dummy sig.txt file that makes no signature correction. It is loaded in the ESCA 2000 folder. To use this default file make sure the path points to the ESCA 2000 folder. If you set up a custom folder then enter the custom path statement in the Signature file Path window.

The Dither box should be checked if a 2502 fast detector and 2503 buffer memory are used. If a 2401 Position computer is used do not check the Dither box.

Horizontal Linerization is not available in this release.

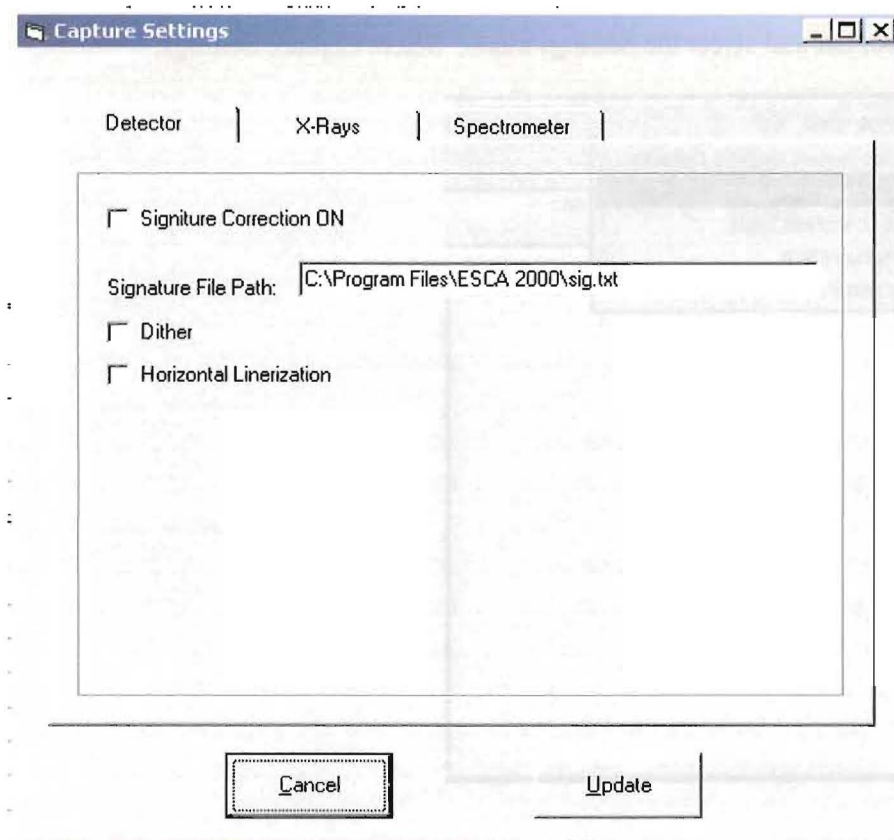

Calibration and Setup – Hardware configuration – X-Rays

Standard settings for a Monochromator system.

- A. Source Type: Al
- B. Filter: Monochromator
- C. Reference Energy: 1486.6 is provided as the accepted value
- D: Please select the type of X-Ray gun controller

Note: “Other” is used for X-Ray guns that are not controlled from this software. The VG 8730 can be controlled using the 8702 L/S.

The screenshot shows a software window titled "Capture Settings" with three tabs: "Detector", "X-Rays", and "Spectrometer". The "X-Rays" tab is active. The settings are as follows:

Source Type	Al	Reference Energy	1486.6
Filter	Monochromator	Spot controller	8702 Spot

Satellite Subtraction Parameters:

Satellite	Offset	Amplitude	Filter Transmission Fraction	
			Near Pk	Far Pk
			1	1

At the bottom of the dialog, there are two rows of buttons: "Cancel" and "Update".

Non-Monochromator Systems

- A. Select source Type from list
- B. Select None or Foil.

None will establish a list of satellite peaks with full intensities as specified in the literature. Foil will allow adjustment of the satellite intensities. This is an empirical process. We assume the satellites are attenuated by the window foil. The Filter Transmission Fraction is the Transmission for the satellite peak compared to the Primary

peak. The Transmission Fraction can be specified for the satellite nearest the Primary peak and the satellite farthest from the Primary peak. A linear variation in transmission is computed for the intermediate peaks.

The Filter Transmission Fractions are determined by collecting a spectrum and then using the Satellite subtract function in the Tools menu found at the top of the spectrum display window. Adjust the Filter Transmission Fraction for the Near Peak until the subtraction produces a smooth baseline in the region of the near satellite. Then adjust the Filter Transmission Fraction for the far peak. You may need to iterate the setting a few times. Your final Transmission values will be saved with all spectra at the time of capture. The satellite subtraction can be performed in the Capture program or the Data Analysis program.

Refer to Satellite Subtraction in the Data Analysis section under Manipulating Spectra.

Calibration and Setup – Hardware configuration – Spectrometer

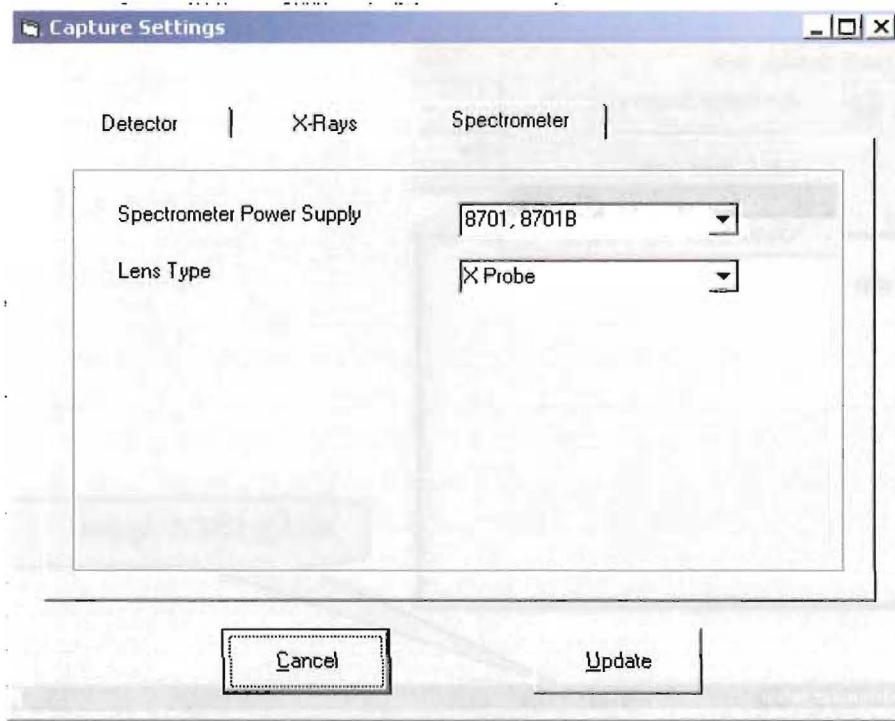

1. Select the type of spectrometer power supply from the drop down list.
2. Select the type of lens from the drop down list.

If the Spectrometer Power Supply entry is changed then you must exit the Capture Application and re-start it so the instrument interface and be re-initialized. You will be reminded of this requirement when the Capture Setting Dialog is closed.

Updating the Registry

If you Cancel the dialog or use the "X" button, none of the changes made during your

Updating the Registry

If you Cancel the dialog or use the "X" button, none of the changes made during your session with the Capture Setting Dialog will be saved. You must use the Update button to save your changes. The dialog will close after the Updates are complete, so it is convenient to make all desired changes before Updating.

Calibration and Setup – Calibration Parameters

The calibration parameters are entered into the Configuration Table located on the Configuration Tab.

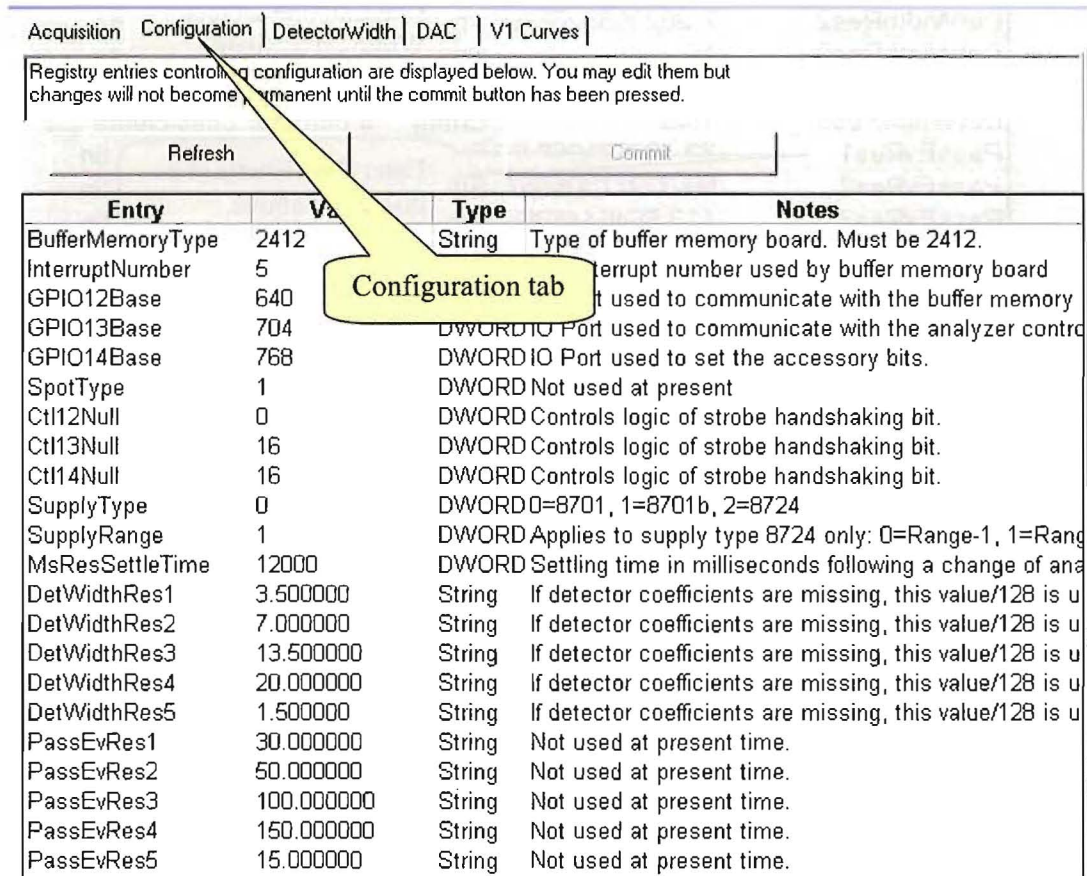

Acquisition | **Configuration** | Detector/Width | DAC | V1 Curves |

Registry entries controlling configuration are displayed below. You may edit them but changes will not become permanent until the commit button has been pressed.

Refresh

Entry	Value	Type	Notes
BufferMemoryType	2412	String	Type of buffer memory board. Must be 2412.
InterruptNumber	5	String	Interrupt number used by buffer memory board
GPIO12Base	640	String	IO Port used to communicate with the buffer memory
GPIO13Base	704	DWORD	IO Port used to communicate with the analyzer control
GPIO14Base	768	DWORD	IO Port used to set the accessory bits.
SpotType	1	DWORD	Not used at present
Ctl12Null	0	DWORD	Controls logic of strobe handshaking bit.
Ctl13Null	16	DWORD	Controls logic of strobe handshaking bit.
Ctl14Null	16	DWORD	Controls logic of strobe handshaking bit.
SupplyType	0	DWORD	0=8701, 1=8701b, 2=8724
SupplyRange	1	DWORD	Applies to supply type 8724 only: 0=Range-1, 1=Range-2
MsResSettleTime	12000	DWORD	Settling time in milliseconds following a change of analog
DetWidthRes1	3.500000	String	If detector coefficients are missing, this value/128 is used
DetWidthRes2	7.000000	String	If detector coefficients are missing, this value/128 is used
DetWidthRes3	13.500000	String	If detector coefficients are missing, this value/128 is used
DetWidthRes4	20.000000	String	If detector coefficients are missing, this value/128 is used
DetWidthRes5	1.500000	String	If detector coefficients are missing, this value/128 is used
PassEvRes1	30.000000	String	Not used at present time.
PassEvRes2	50.000000	String	Not used at present time.
PassEvRes3	100.000000	String	Not used at present time.
PassEvRes4	150.000000	String	Not used at present time.
PassEvRes5	15.000000	String	Not used at present time.

After entering changes to the values you must select the Commit button to write the changes to the registry.

Type 5000 for the MSResSettleTime. This will shorten the wait time when the resolution is changed from 12 seconds to 5 seconds. After entering changes to the values you must select the Commit button to write the changes to the registry.

Type 5000 for the MSResSettleTime. This will shorten the wait time when the resolution is changed from 12 seconds to 5 seconds.

If you have calibration values from the HP workstation (9800 series) then one adjustment to the calibration values is required. For each Resolution correct the pass energy. Use the Detector Width for the same Resolution as the Pass Energy.

$$\text{New Pass energy} = \text{Old Pass energy} + (\text{Detector Width})/2$$

If you are upgrading from the DOS Vectra software or have installed a new operating system then use the pass energy that was previously used.

Calibration and Set up – Calibration Parameters cont.

Make the following entries to the Configuration table if data is available.

Entry	Value	Type	Description
DetWidthRes1	2.6411791632707	String	Used to calculate the \
DetWidthRes2	7.2823583265405	String	Used to calculate the \
DetWidthRes3	15	String	Used to calculate the \
DetWidthRes4	21	String	If detector coefficients
DetWidthRes5	1.45	String	If detector coefficients
PassEvRes1	23.193691966457	String	Used to calculate the \
PassEvRes2	59.32277305557	String	Used to calculate the \
PassEvRes3	113.56464458566	String	Used to calculate the \
PassEvRes4	166.59617714210	String	Not used at present tin
PassEvRes5	12.8	String	Not used at present tin
SensitivityExpRes1	0.700000	String	Used in normalizing pe
SensitivityExpRes2	0.700000	String	Used in normalizing pe
SensitivityExpRes3	0.700000	String	Used in normalizing pe
SensitivityExpRes4	0.700000	String	Used in normalizing pe
SensitivityExpRes5	0.700000	String	Used in normalizing pe
V1OffsetRes1	59.857340	String	Used to calculate the \
V1OffsetRes2	84.0197	String	Used to calculate the \
V1OffsetRes3	142.721457	String	Used to calculate the \
V1OffsetRes4	226.855499	String	Used to calculate the \
V1OffsetRes5	100.000000	String	Used to calculate the \
V1SlopeRes1	0.423228	String	Used to calculate the \
V1SlopeRes2	0.442913	String	Used to calculate the \
V1SlopeRes3	0.492126	String	Used to calculate the \
V1SlopeRes4	0.545024	String	Used to calculate the \
V1SlopeRes5	0.500000	String	Used to calculate the \
DeltaEvSpot1	0.000000	String	Used to calculate the \
DeltaEvSpot2	0.000000	String	Used to calculate the \
DeltaEvSpot3	0.000000	String	Used to calculate the \
DeltaEvSpot4	0.000000	String	Used to calculate the \
DeltaEvSpot5	0.000000	String	Used to calculate the \
XyzMotorsOn	0	DWORD	Used to calculate the \
RMotorOn	0	DWORD	Used to calculate the \
DeltaEvSpot4	0.000000	String	Used to calculate the \
DeltaEvSpot5	0.000000	String	Used to calculate the \
XyzMotorsOn	0	DWORD	Used to calculate the \
RMotorOn	0	DWORD	Used to calculate the \
RCode	1106	DWORD	Determines GPIB devic
XCode	1107	DWORD	Determines GPIB devic
YCode	1108	DWORD	Determines GPIB devic
ZCode	1109	DWORD	Determines GPIB devic
Cal_VD_8701	40	String	Used to translate volta
Cal_VD_300_8724	640	String	Used to translate volta
Cal_VD_1500_8724	163.9	String	Used to translate volta
Cal_VD_3000_8724	80.000000	String	Used to translate volta
Cal_V1_8701	40.000000	String	Used to translate volta
Cal_V1_8701	40.000000	String	Used to translate volta

Calibration and Set up – Establishing starting calibration values cont.

3. Calculate the following:
New PassEVRes4 = $166 + (\text{measured peak position} - 84)$.
Enter the new pass energy into the configuration table and select Commit.
4. Set up following unscanned spectrum
 - a. Remove the check mark from the box titled “Scanned”.
 - b. Center BE = 85.8.
 - c. Window Width = It will use the Detector Width. No input needed.
 - d. Number of data points = It will use 128. No input needed.
 - e. Number of Scans/Reads = 200
 - f. Start AccumulationAfter spectrum is accumulated, use cursor to measure separation between the Au 4f 5/2 and Au 4f 7/2 peaks.
5. Calculate the following:
New DetWidthRes4 = $19 * (3.68 / \text{measured peak separation})$.
Enter new Detector Width into configuration table and select Commit.
6. Make following entries:
 - a. DetWidthRes2 = $(\text{DetWidthRes4}) / 3$
 - b. DetWidthRes3 = $(\text{DetWidthRes2}) * 2$
 - c. PassEVRes2 = $(\text{PassEVRes4}) / 3$
 - d. PassEVRes3 = $(\text{PassEVRes2}) * 2$

These starting values will now be used in the automatic program to refine the calibration.

Calibration and Set up - Run DAC to calibrate BE span.

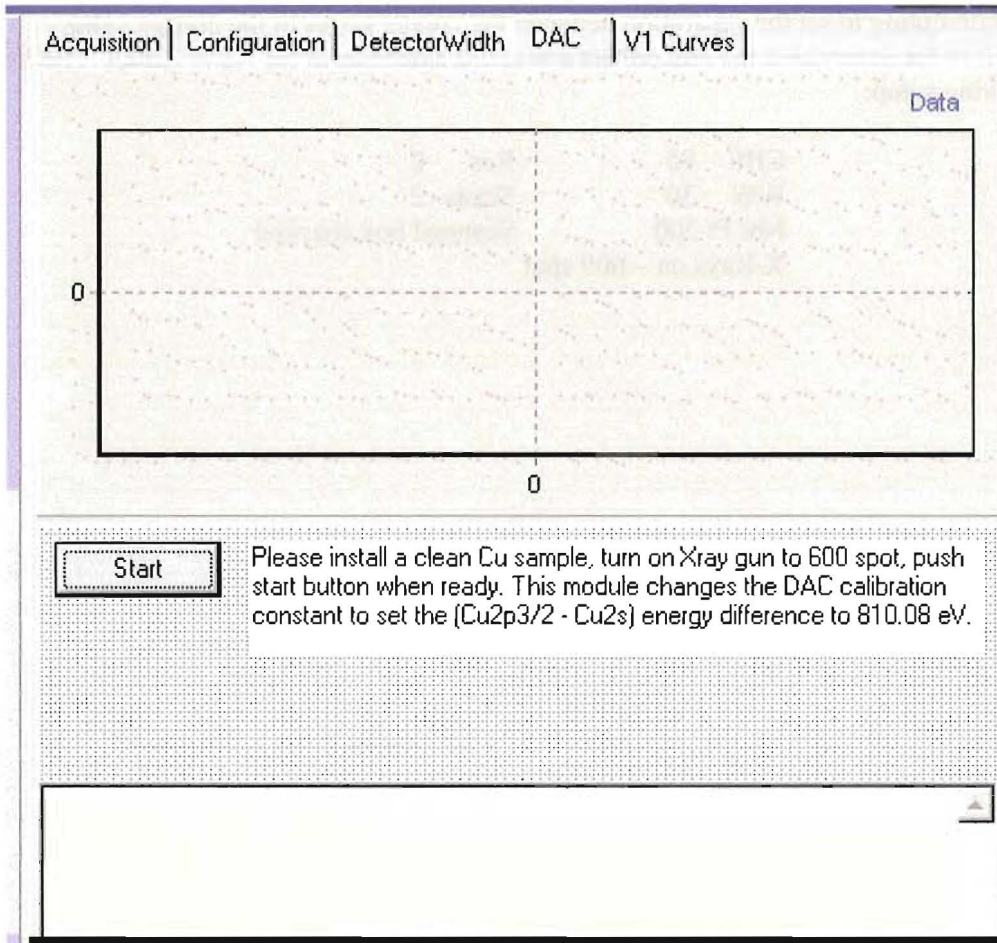

The DAC calibration is very simple. Align the copper sample under the microscope. Clean the sample with an Ion Etch. Then select start. The spectra will be displayed as they are collected. The display window will provide information as the calibration progresses.

The DAC calibration may fail to find the Cu 3s1/2 peak in the preset window. Small errors in the DAC constant will cause large errors in the Cu 3s1/2 peak location. You will need to provide an improved initial estimate of the DAC value. Run a 100 Ev wide scan centered at 120 Ev and a 50 Ev scan centered at 930 Ev. Find the centers of the Cu 3s 1/2 and Cu 2p 3/2 peaks using the cursor. Compute:

$$((\text{Cu } 2p_{3/2} - \text{Cu } 3s_{1/2}) \text{ energy separation} / 810) * \text{current DAC}$$

Enter this value of the DAC into the configuration table. Follow steps 1 through 3 above to re-establish the Au 4f7/2 line position to 84 Ev. Re-run the DAC calibration.

Calibration and Set up – DAC calibration – cont.

The DAC calibration can leave the absolute binding energy far out of adjustment. It is only attempting to set the separation between the copper peaks to the correct value. Return to the acquisition tab and collect a scanned spectrum at the Au 4f peaks. Use the following setup:

CBE	85	Res	2
WW	30	Scans	2
Nbr Pt	300	Scanned box	checked
X-Rays	on – 600 spot		

Calibration and Set up - Detector Width Calibration

Use the cursor to find the center BE for the Au 4f 7/2 peak. Find the value of PassEVRes2 in the configuration table. Calculate:

New PassEVRes2 = current PassEVRes2 + (measured peak position – 84).

Enter the new value of the Pass Energy into the Configuration Table. Make the same calculation for Res 3 and Res 4 but use the Res2 value (measured peak position - 84). Enter these two values into the configuration table. Select Commit to record all three updated values to the registry.

Select the Detector Width Tab. Set the run conditions for Res2, Res3 and Res4 as shown below. Select start. Watch the calibration proceed. If the calibration fails to find two peaks it is usually because the peaks are not well enough centered in the window. Make small changes to the pass energy as described in the paragraph above to center the peaks and try again. This calibration sets the absolute BE for all pass energies.

Note: Increasing the pass energy moves the peaks to lower BE.

	Res 2	Res 3	Res 4
Secs unscanned mode:	60	30	15
Scans for pe adjustment	2	1	1

Calibration and Set up - V1 curves

This calibration is only needed if the V1 supply is digitally controlled. The V1 curves settings will have no effect on a model 8701 Spectrometer supply unless the supply has a digital V1 upgrade. The optimum voltage setting information may be useful for manual adjustment of the supply.

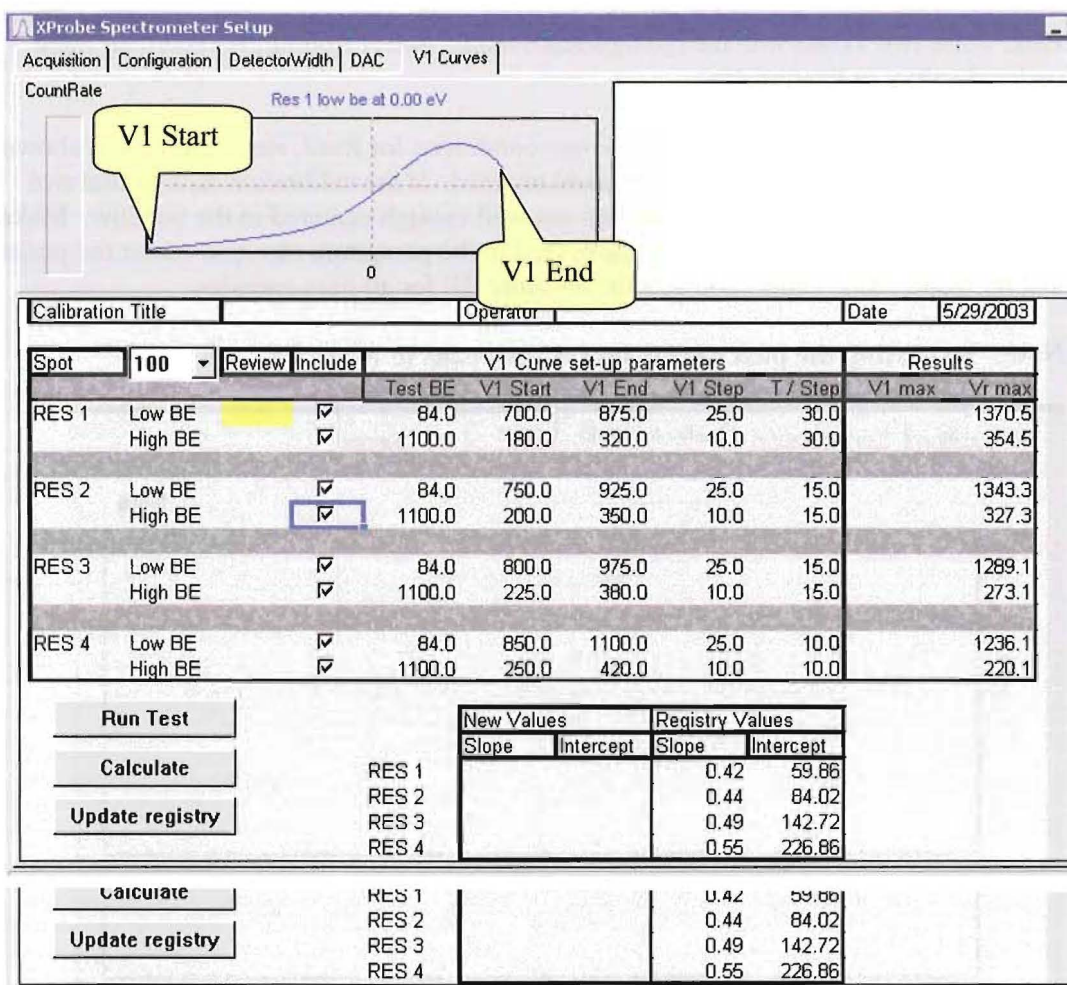

The V1 curve generator.

The object of running V1 curves is to obtain a set of parameters that optimize the lens throughput for all binding energies. The voltage (V1), that is used to focus the lens, is continuously increased over a range of voltages. As the V1 voltage is changed the number of electron that reach the detector is changed. The goal is to set a start and end for the V1 voltage ramp that produces a maximum detector signal away from either end.

Calibration and Set up - V1 curves – cont.

Each Resolution requires two V1 curves. All curves are created using gold as the sample. The spot size setting does not affect the final Slope and Intercept values. It is best to run with larger spots to improve the signal to noise.

The Check boxes, under the include column, control which curves will be run. The button labeled “Run Test” will start the data collection. After all pairs, that have been checked, are run use the calculate button to calculate the Slope and Offset parameters. These parameters are used in the software to compute the V1 voltage as a function of V0 (retardation) voltage that will keep the lens focus optimized for all binding energies. Review the computed values. The slopes and intercepts should increase smoothly and the resolution number is increased.

Finally select the update registry button to make the new values take effect.

Calibration and Set up – Signature correction

Return to the main Capture program

Select the Capture Settings dialog.

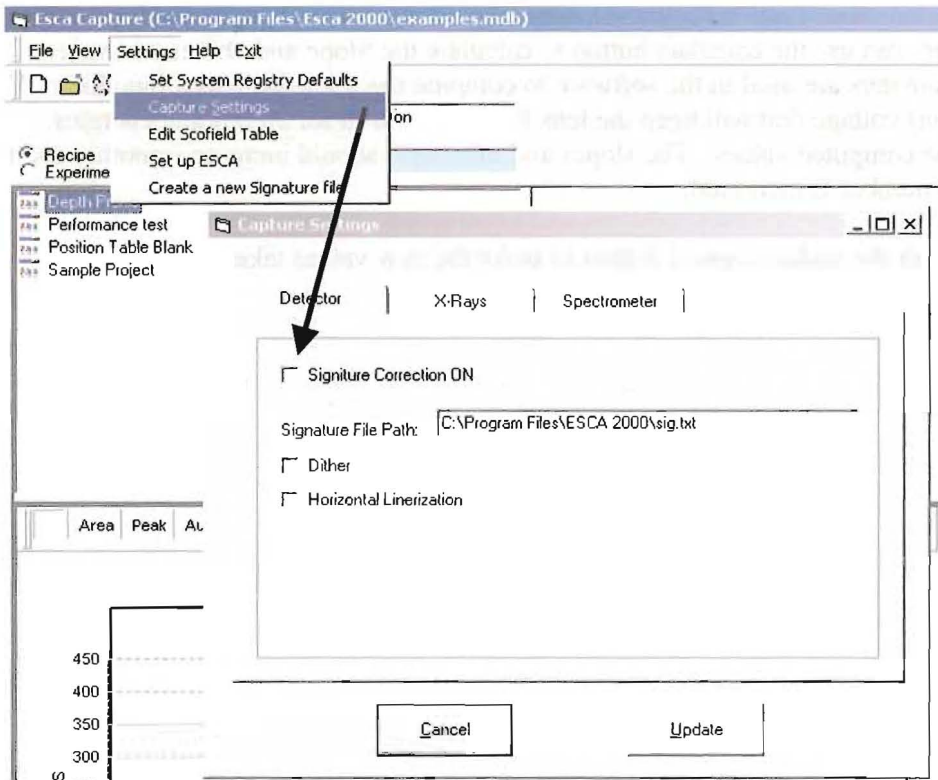

If the ESCA uses a Model 2401 Position computer then the Dither box should not be checked. Check the Dither box if a Model 2503 Memory Interface is used.

Remove the checks from the Signature Correction box and horizontal linerization box if the ESCA uses a Model 2401 Position computer then the Dither box should not be checked. Check the Dither box if a Model 2503 Memory Interface is used.

Remove the checks from the Signature Correction box and horizontal linerization box.

Enter the Signature File Path as shown above. This will stop the "Signature file not found." message that is shown when the program is started.

Select update and close the dialog box.

If you have a history of signatures in the C:\Program files\ESCAVB folder, the files can be moved to the C:\Program files\ESCA 2000 folder. These files will have the following endings: sig.txt.1, sig.txt.2, sig.txt.3 etc. Copy all files in this series.

Calibration and Set up – Signature correction cont.

Place an Unscanned Function in the MRS table. Set the CBE to 510eV. Input the time as 10:00 to set it to 10 minutes. Set the spot to 800 microns and the resolution to Res4. Use Default and Temp for the Project and Experiment. The collected data does not need to be saved. The computed signature file is saved.

Select Run.

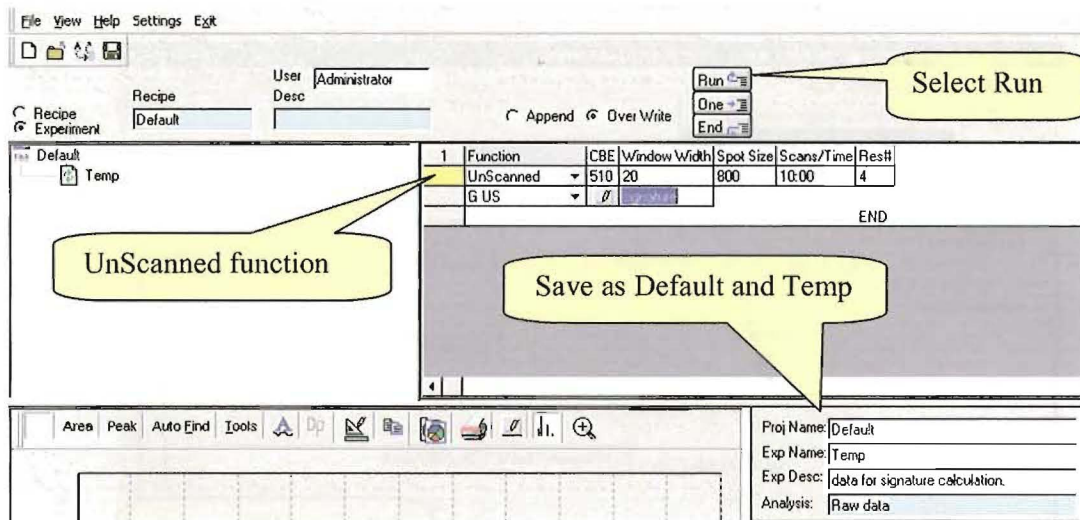

After the data has been collected just leave it displayed. Then select the Setting > Create a new signature file menu.

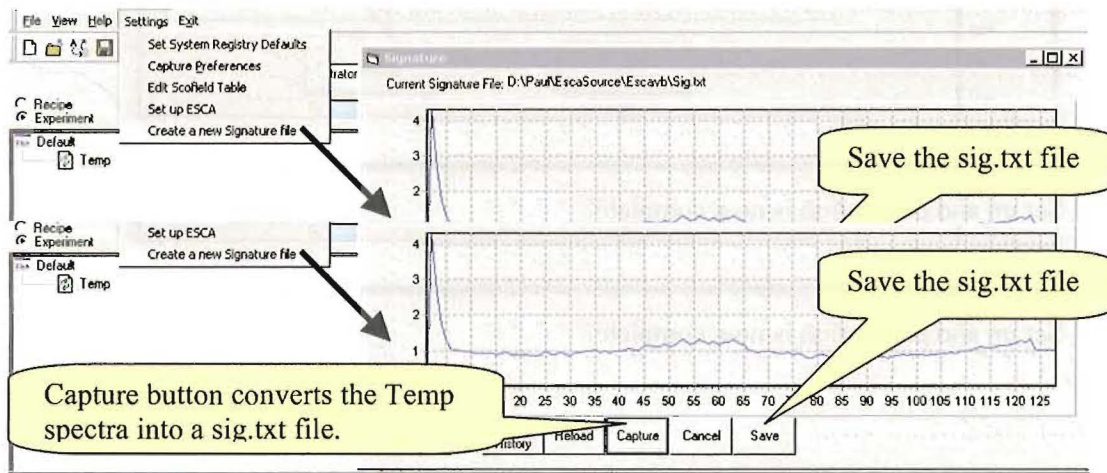

Select the capture button. The signature will be computed from the data in the spectrum display window of the main program. The signature will be displayed in the signature window.

Calibration and Set up – Signature correction – cont.

Select save to save the sig.txt file and back up the last sig.txt as sig.txt.1. All other sig files will be rolled to the next higher number.

Close Signature conversion dialog.

Re-Open the Capture Preferences dialog. Settings > Capture Preferences in main toolbar. Enter a check in the Signature Correction check box.

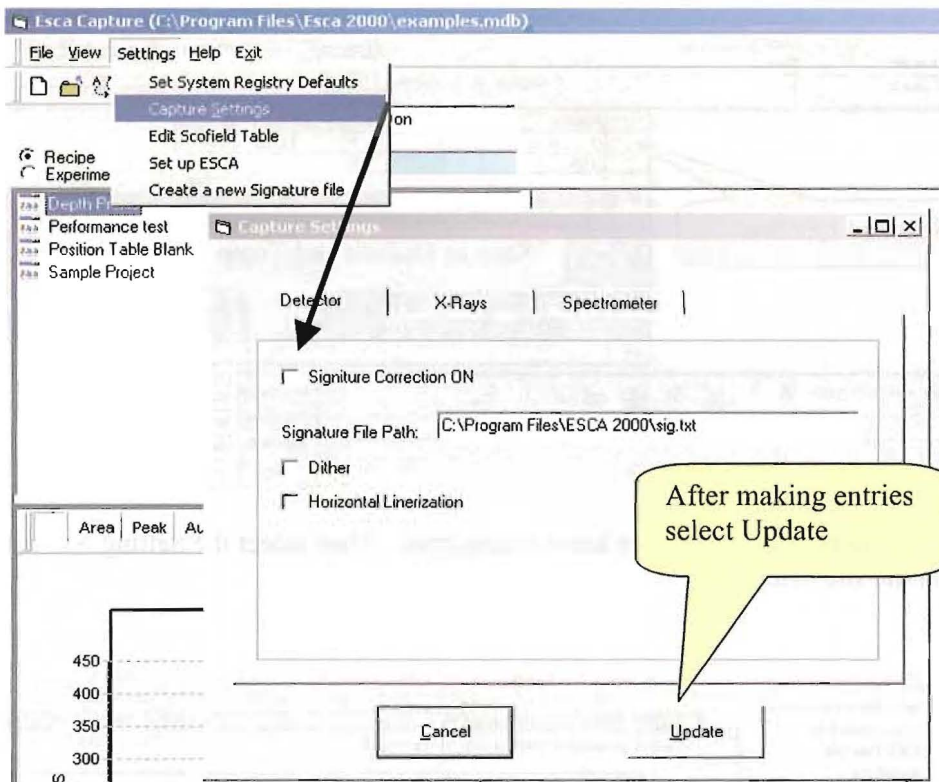

Set up and calibration is now complete.

Set up and calibration is now complete.

Database Functions

It is highly recommended that each user create a personal **Data Base!**
Click on **File > New > New Data Base /Protocol.**

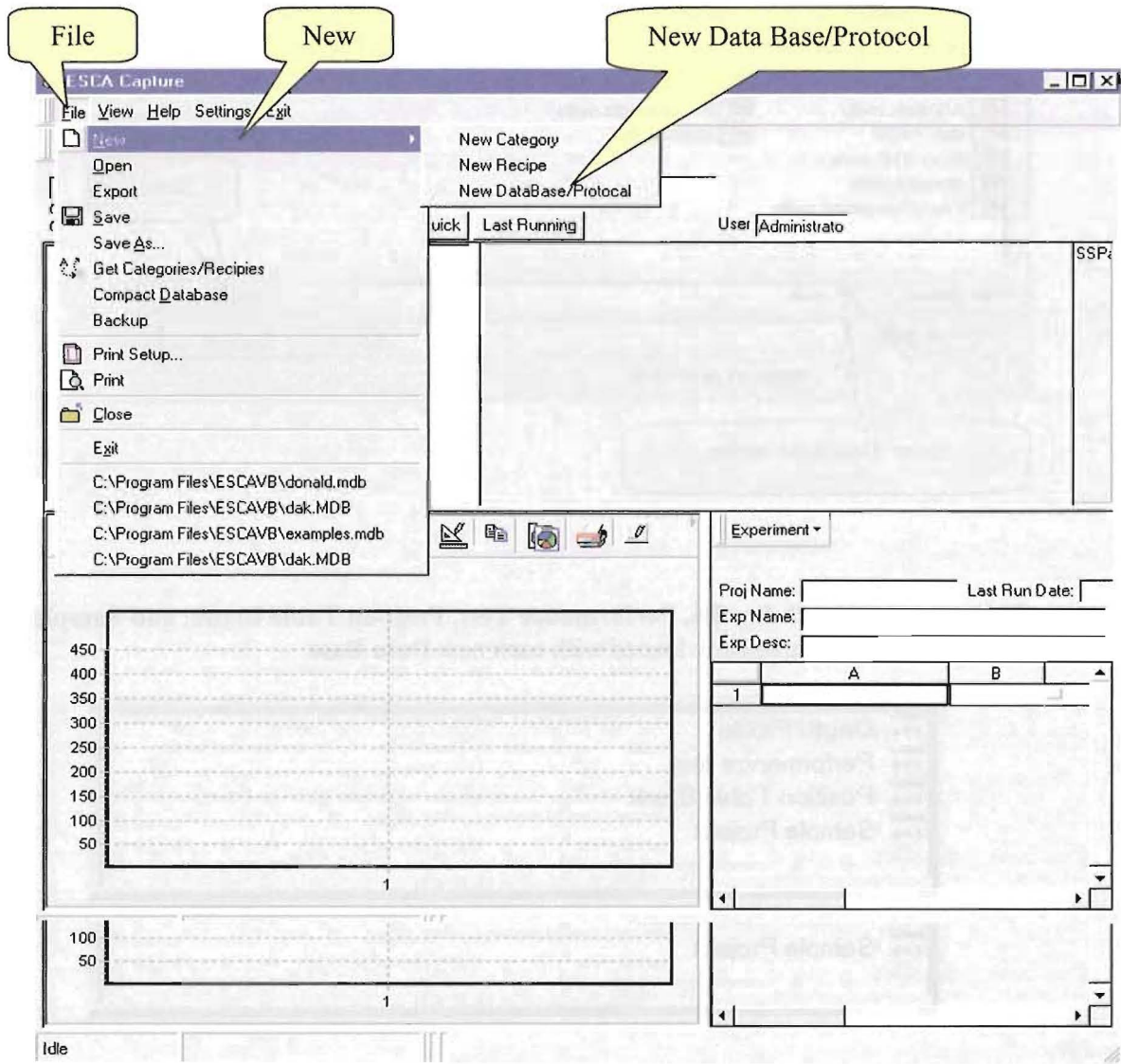

Database Functions – Creating a new database

Enter the new data base name then select **Save**.

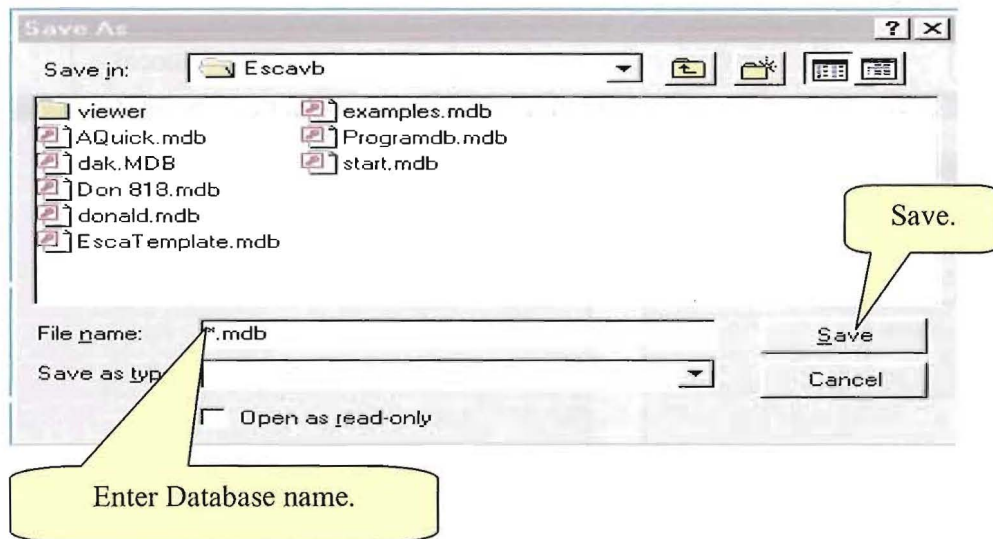

The categories **Depth Profile**, **Performance Test**, **Position Table Blank**, and **Sample Project** will be automatically loaded with each new **Data Base**.



Database Functions – Get recipes from another database

Recipes can be transferred from one **Data Base** to another.

Go to **File > Open >** and select the **Data Base** into which **Recipes** are to be transferred.

Now go to **File > Get Categories/Recipes**

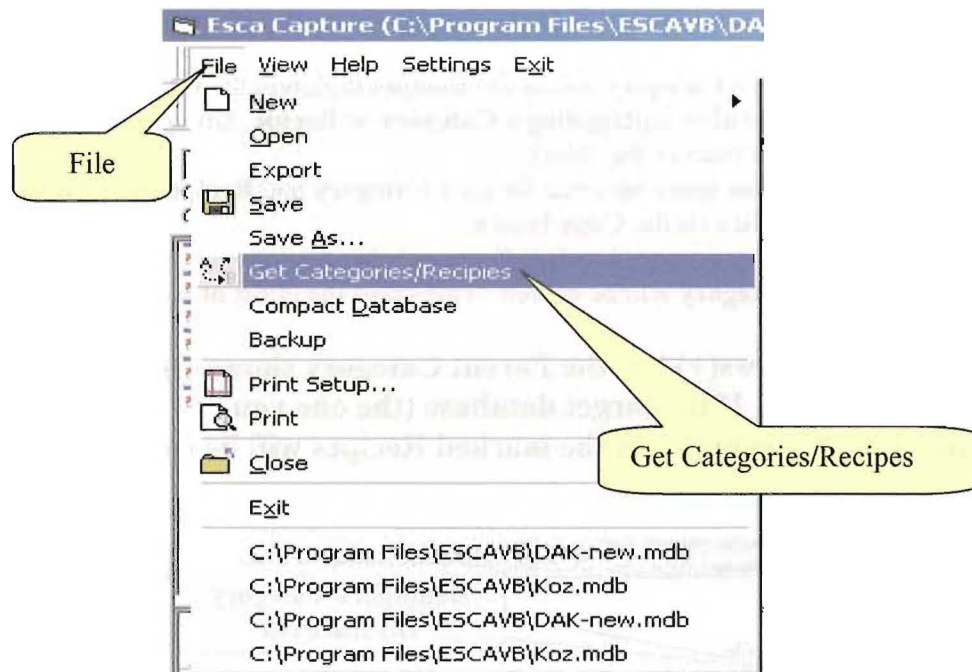

Highlight the **Data Base** that contains the **Categories/Recipes** to be transferred and click on **Open**.

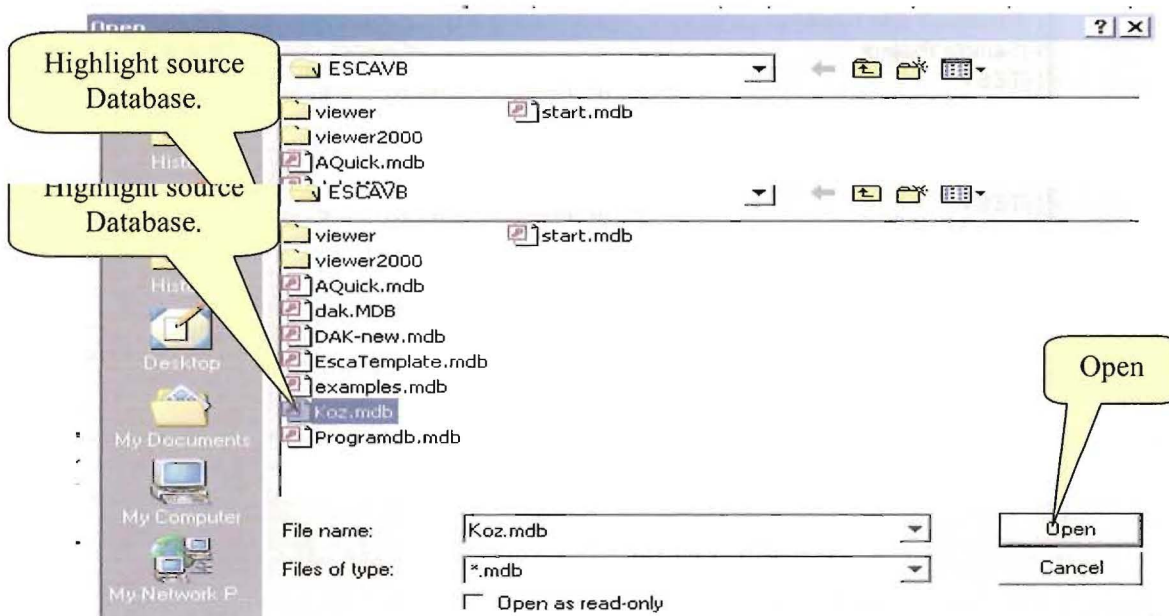

Database Functions – Get Recipes from another database – cont.

!!DO NOT TRANSFER OR ALTER THE TEMPLATE DATA BASES, ESCA Template.mdb or Programdb.mdb!!

In order to transfer a **Category** and/or the **Recipes** highlight the **Category** and hit the space bar (note that after highlighting a **Category** or **Recipe**, hitting the space bar toggles the (-), (+) signs in front of the titles).

Highlight and hit the space bar once for each **Category** and **Recipe** that is to be transferred, then click on the **Copy** button.

If a **Category** is showing a (+) and all **Recipes** below the category show (-) then **all Recipes** in the **Category** will be copied. This saves the effort of checking all **Recipes**.

If a Recipe shows(+) but the Parent Category shows (-) the Recipe may not be copied. If the target database (the one you are coping to) has a matching Category then the marked Recipes will be copied.

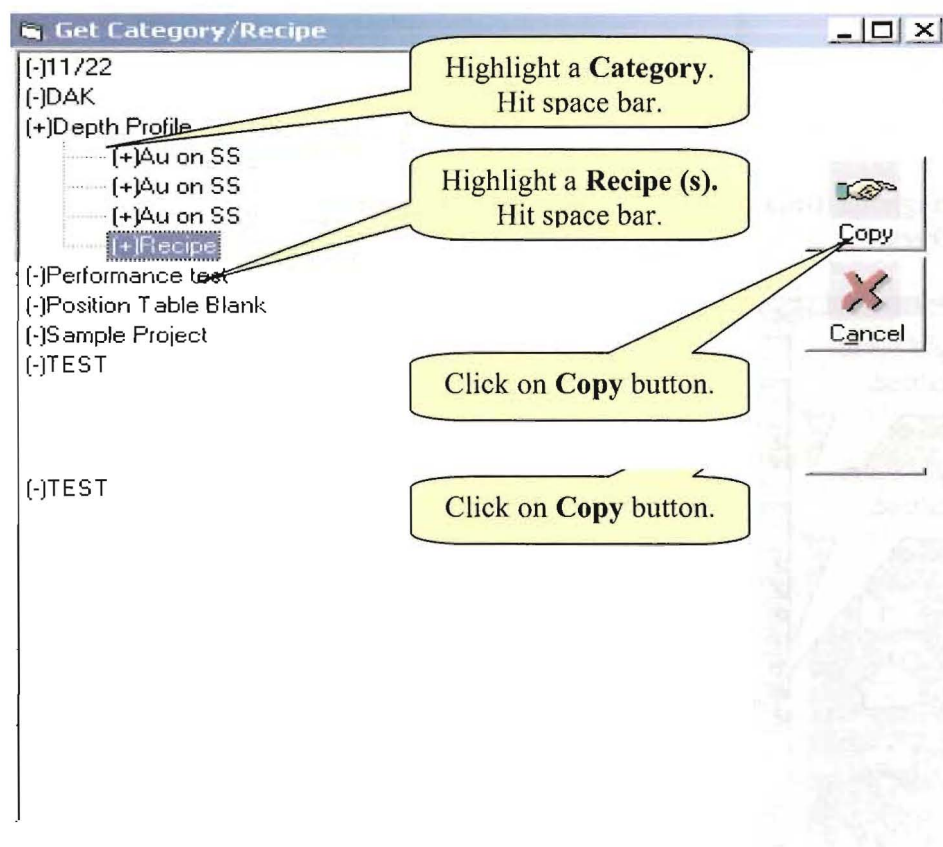

Depth Profiles – Open the depth profile table generator.

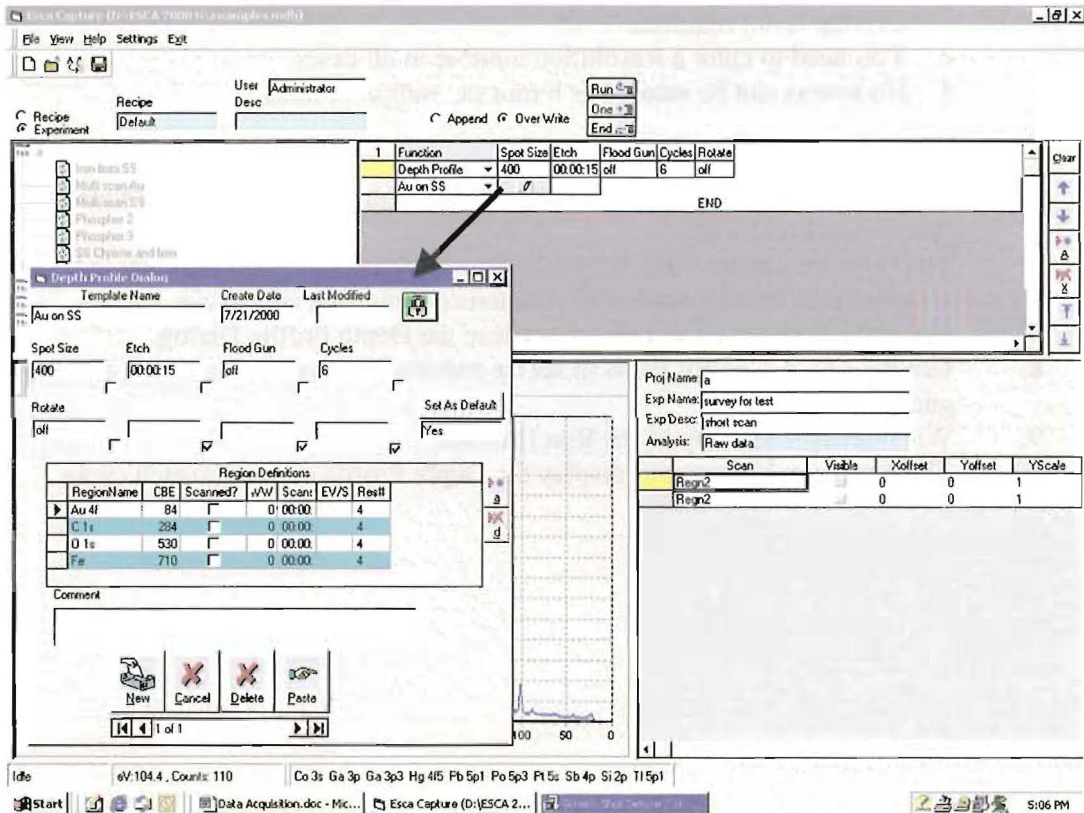

1. Select the Depth Profile function from the function list.
2. We suggest that the first Template be a default Template. Use this as a temporary table. It is rare you will reuse a Depth Profile. Continue to step 4 if you are going to write over the default template.
3. If a reusable template is desired then select New. Edit the Template Name.
2. We suggest that the first template be a default template. Use this as a temporary table. It is rare you will reuse a Depth Profile. Continue to step 4 if you are going to write over the default template.
3. If a reusable template is desired then select New. Edit the Template Name. Go onto next step to define the spectrum regions.
4. Use the Add and Delete buttons to create a table of Region Definitions
 - a. Region name is typically the element symbol and transition label. When this convention is used, the data reduction will automatically identify the transition and look up the Scofield cross-section.
 - b. CBE – Center binding energy
 - c. Scanned – checked WV (window width) must be entered with a non 0 value. Scans is number of scans. If a time is entered as hh:mm:ss, then a number of scans will be calculated, but not shown, that equals or exceeds the time. A default eV/step will be offered.

Depth Profiles – Cont.

- d. Scanned –not checked. WW defaults to detector width, Scans/Time is collection time and can be entered as seconds or hh:mm:ss and finally eV/step is not required.
 - e. You need to enter a Resolution number in all cases.
 - f. Hh:mm:ss can be entered as h:mm:ss, mm:ss or m:ss.
5. Set up the Spot Size, Etch Time in seconds or hh:mm:ss, Flood gun state and Number of Etch cycles.
 6. The Rotation can be “On” or “Off”. If rotation is “On” then the sample holder will rotate an integer number of rotations during each etch cycle.
 7. Select Paste to Save the Table and Close the Depth Profile Dialog.
 8. Use the ESCA Control Panel to set up and test the sample alignment, and ion gun operation.
 9. When ready select any of the Run Buttons.
 10. The Spectrum Viewer will display the Depth Profile during the etch cycle.

ESCA Control Panel

Previous versions of the software used **A Quick** as a simplified control panel. This update replaces **A Quick** with the **ESCA Control Panel**.

The first row of the panel presents **check boxes** allowing for the activation of the **Flood Gun** (charge neutralization), **Ion Gun**, **X-ray Gun** and, if applicable, **Aperture**. Changes in these parameters take effect when the boxes are clicked.

The second row and third row are grouped together in a frame. The fields represented in the frame directly control the spectrometer. The Panel is shown with the scan variable not checked. This is the **UNSCANNED** mode. The active variables are (**CBE**), **Spot size**, **spectrometer Resolution**, and **Capture T (time in seconds)**. Changes in these parameters take effect when the start button is clicked.

ESCA Control Panel – Unscanned mode

The screenshot shows the ESCA Control Panel window. The title bar reads "ESCA Control Panel". The main area is titled "Spectrometer Controls".

Callout 1 (Left): "on/off toggles for Flood Gun, Ion Gun, X-ray Gun" points to the checkboxes for "Flood Gun", "Ion Gun", and "X-ray Gun Operate". "pull-down menu for Aperture" points to the "Aperture" dropdown menu.

Callout 2 (Right): "windows for CBE, and Capture T" points to the "CBE" and "Capture T" input fields. "pull-down menus for Spot size, and Resolution" points to the "Spot size" and "Resolution" dropdown menus.

Callout 3 (Bottom): "ESCA Control Panel spectrum viewer" points to the large empty plot area at the bottom of the window.

The interface includes a "START *" button, "Abort", and "Exit" buttons. Below the controls are two empty plot areas, each with a "0,0" label in the top right corner.

ESCA Control Panel - Scanned Mode

Placing a check in the **Scans** box provides access to **Scans** number, **Window** width, **eV/step**, and **Time/step**.

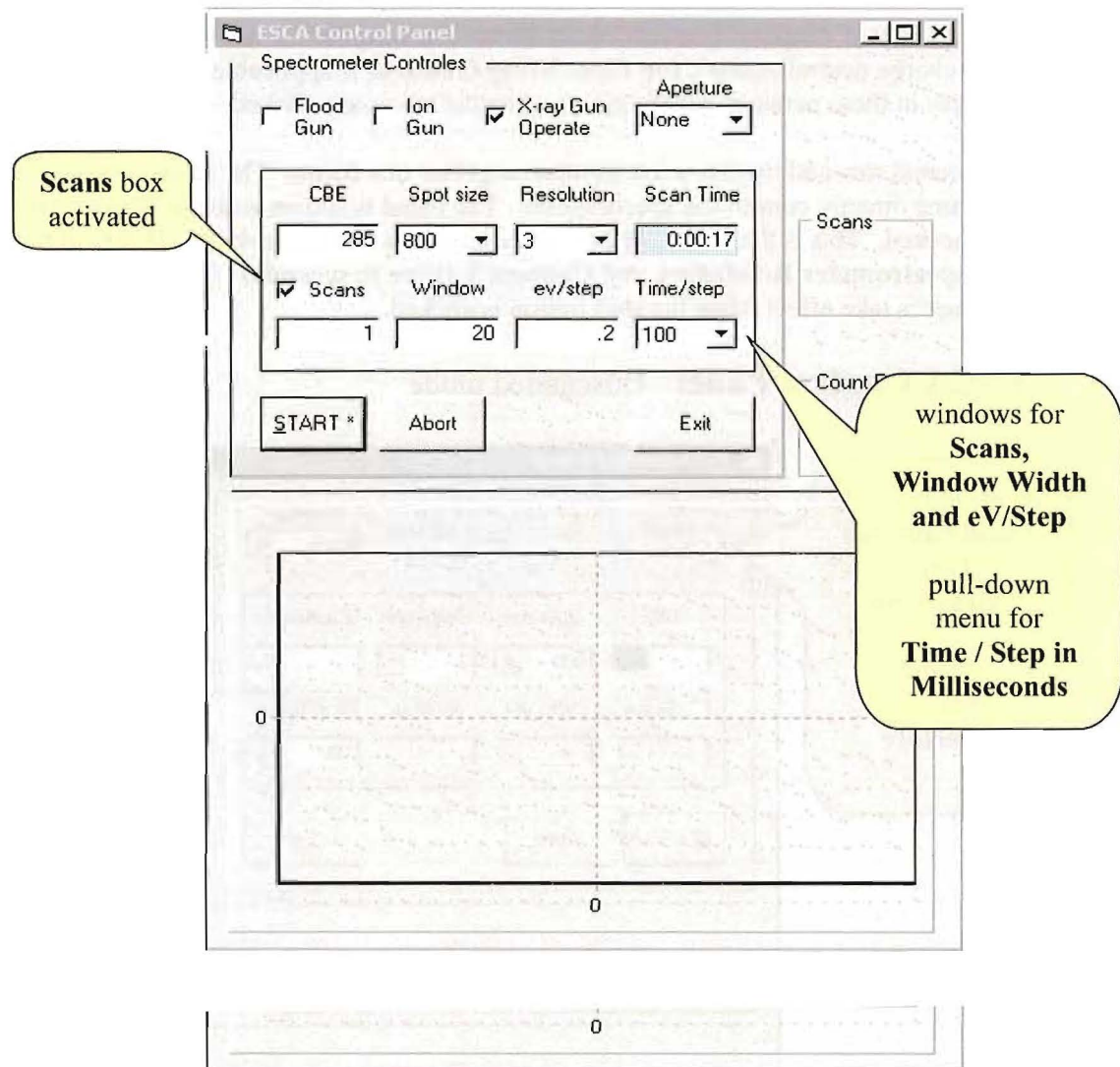

The scanned mode is especially useful for establishing the center binding energies of those elements of interest for High Resolution Spectroscopy and also for establishing optimum flood gun parameters.

Note that, while in the scanned mode, the **Scan Time** field is shaded blue. This indicates that the **Scan Time** field is a Read-Only field as it is a variable dependent on the other scan parameters.

ESCA Control Panel - Quick survey.

Place a check in the **Scans** box, type 500 or 550 into the **CBE** box and 1000 or 1100 respectively in the **Window** box.

Set Time/step to 50 and click on **START**.

Note: The overhead time per step is 25 milliseconds. This is not included in the Scan time calculation.

The screenshot shows the ESCA Control Panel software interface. The main window has a menu bar (File, View, Help, Settings, Exit) and a toolbar with buttons for Run, One, and End. Below the menu bar are several control panels:

- Settings Panel:** Includes checkboxes for Big Status Display, Data Reduction, ESCA Control Pnl, Motion Control Pnl, and Scan List. It also has an X-ray Gun Operate section with an Aperture dropdown set to None.
- Parameter Panel:** Contains input fields for CBE (285), Spot size (800), Resolution (3), and Scan Time (0:00:17). It also has checkboxes for Scans and a Window section with fields for ev/step (20) and Time/step (100).
- Buttons:** START*, Abort, and Exit.
- Scans Panel:** A section with a 'Scans' label and a 'Count Rate' label.
- Table:** A table with columns for Spot Size, Etch, Flood Gun, and Cycl. The Spot Size column has a value of 400.
- Graphs:** A large empty graph area with axes labeled 0 and 0.0. A 'Current Count Rate' label points to a small bar graph.
- Status Display:** A separate window at the bottom titled 'Status Display' showing 'Text1'.

Callouts provide additional information:

- 'See Big Display at bottom of Panel.' points to the 'Big Status Display' checkbox.
- 'Scans or Time Remaining' points to the 'Scans' label.
- 'Current Count Rate' points to the 'Count Rate' label.
- 'Very large display of' points to the large graph area.
- 'Very large display of Count Rate.' points to the small bar graph.
- 'This display can be expanded and moved. Additional status parameters are then displayed. Available during normal capture.' points to the 'Status Display' window.

Calibrating the Microscope for Correct Sample Registration

Place a phosphor sample on a flat stage and transfer it to the UHV chamber.

Use the joystick to manipulate it to the vicinity of the registration point.

Turn on the **Flood Gun**, and **X-rays**.

Set the **CBE** for O(1s) at ~532 eV.

Choose the largest **Spot size**, **Resolution 4**, and a large number for **Capture T** (3000seconds?).

While monitoring the counts adjust the Z-axis of the **stage** for maximum counts.

Also, insure that the "dot pattern" on the CRT is centered (side-to-side).

NOW, UNTIL THE MICROSCOPE HAS BEEN CALIBRATED, DO NOT USE THE JOY STICK OR DO ANY OTHER MANIPULATIONS TO THE STAGE.

Turn off the flood gun (the flood gun emission may make the area irradiated by the X-rays difficult to see).

Use the 50X magnification and the eyepiece cross hairs, adjust the Z-axis of the **microscope** so that the irradiated area of the phosphor is in focus.

Now use the **microscope's** X and Y-axes controls to move the eyepiece crosshairs to the center of the **in-focus** irradiated area on the phosphor.

If a small **Spot size** is to be used change the **Spot size** settings to the appropriate size and recheck the crosshair alignment using the **microscope** X and Y-axes adjustments.

The microscope is now calibrated.

Now use only the joystick controls to bring samples into focus and areas of interest under the eyepiece crosshairs.

Experiment Names as part of the database structure

The Project and Experiment Names are displayed in a number of places in the program. The **two names** together form a unique identity for a MRS, Depth profile or one position in a position table. Examples of the tree structures that help to find your data are shown below.

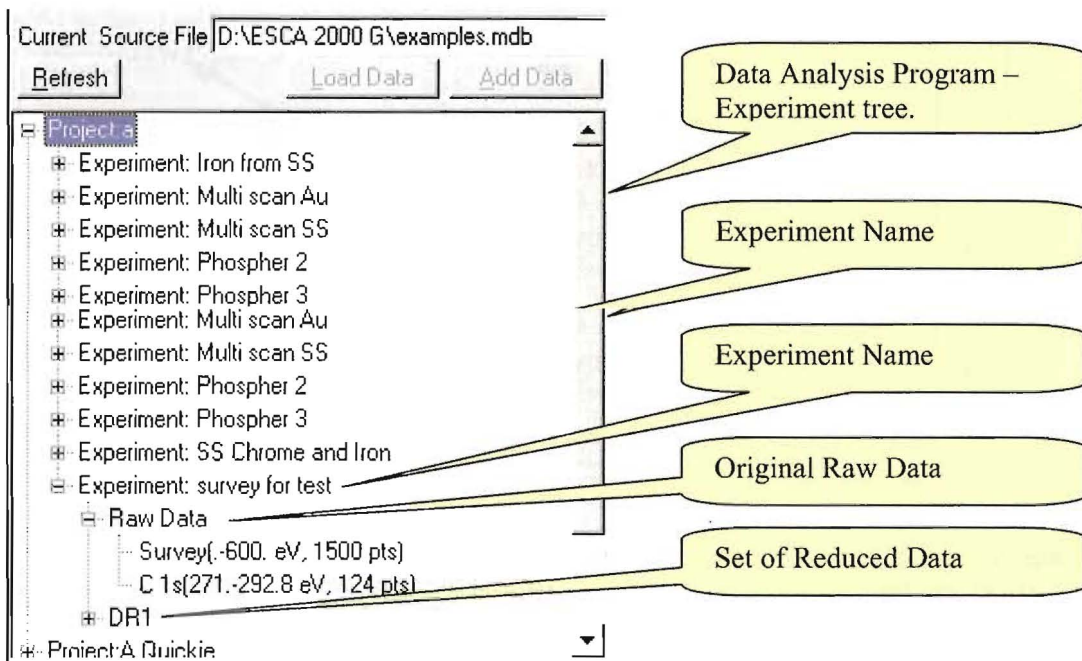
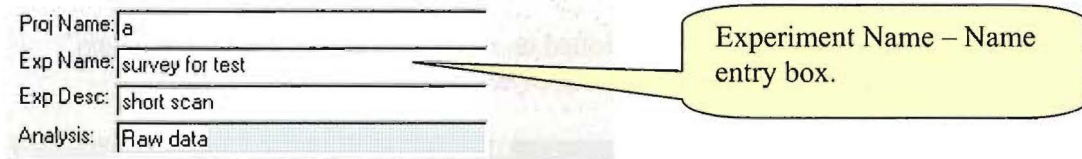
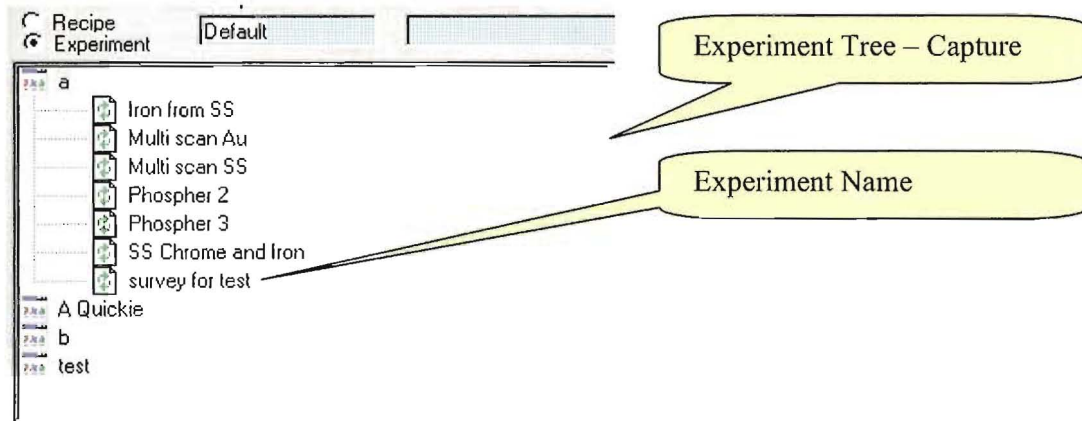

Data Analysis keeps Reduced data with Raw Data for ease of recovery. Raw data is never presented for manipulation. Only a copy is presented in the Spectrum Viewer.

Graphics controls – Chart editor

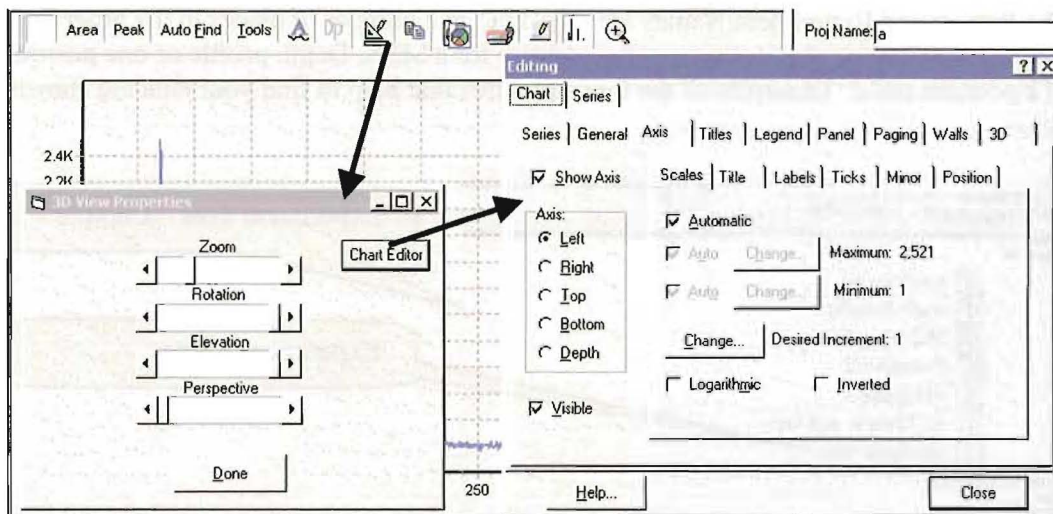

The chart editor provides control over all aspects of the Graphic presentation of the spectra. In the following sequence of screens we will show some of the typical controls.

The X and Y axis presentation is controlled on the Axis > Scales page. The “Axis” column in the left frame controls the focus of the “Axis” sub pages.

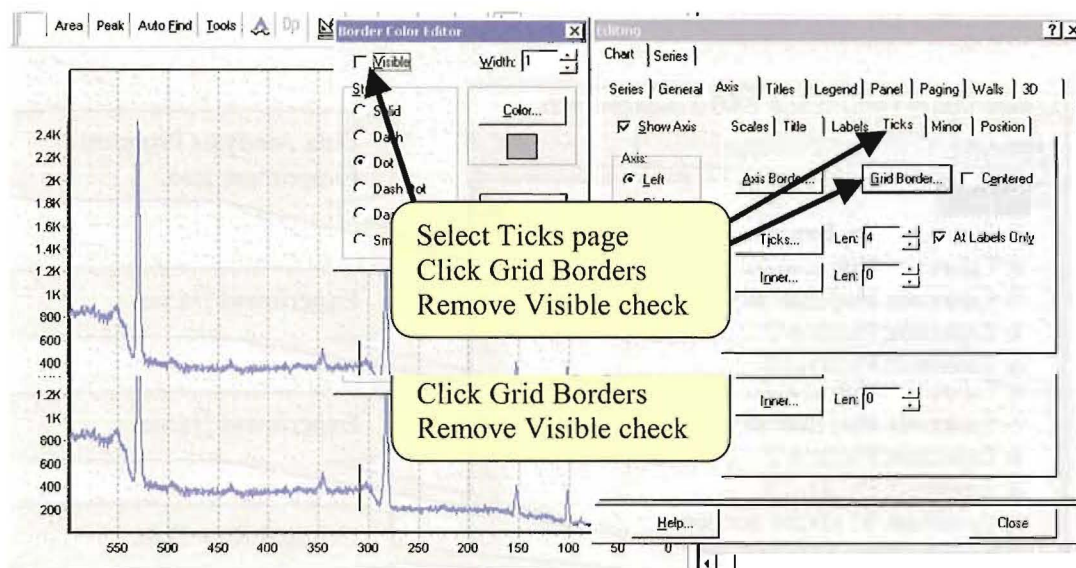

Removing grid lines for X axis. The axis control was changed to Bottom to remove the vertical grid lines in the next screen.

Graphics controls – Chart Editor –cont.

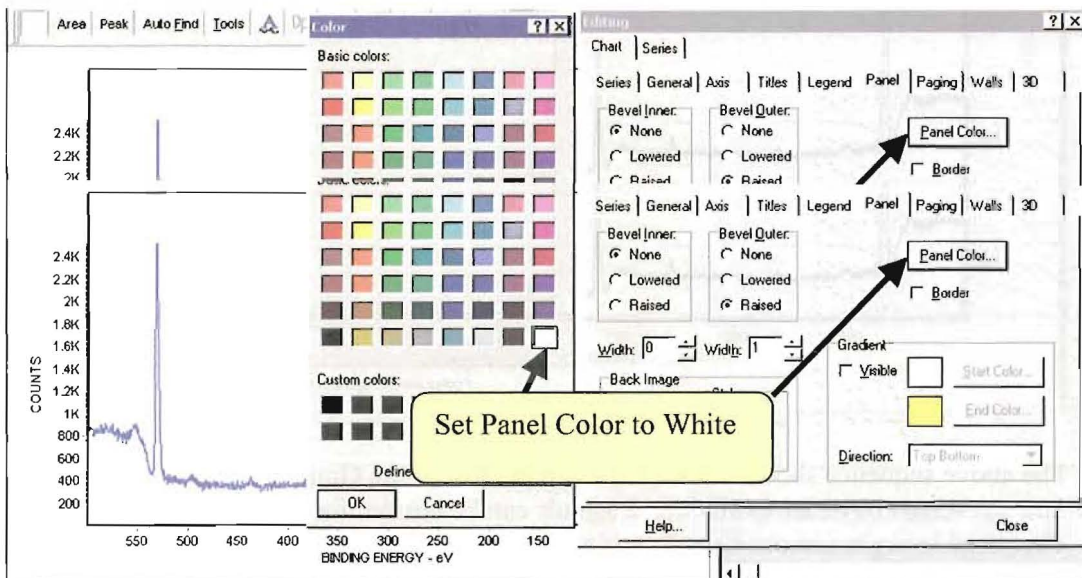
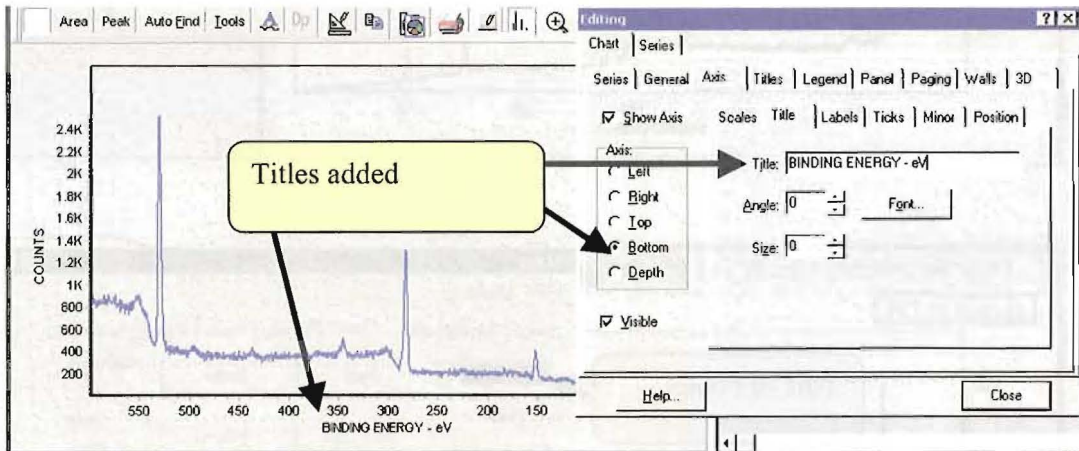
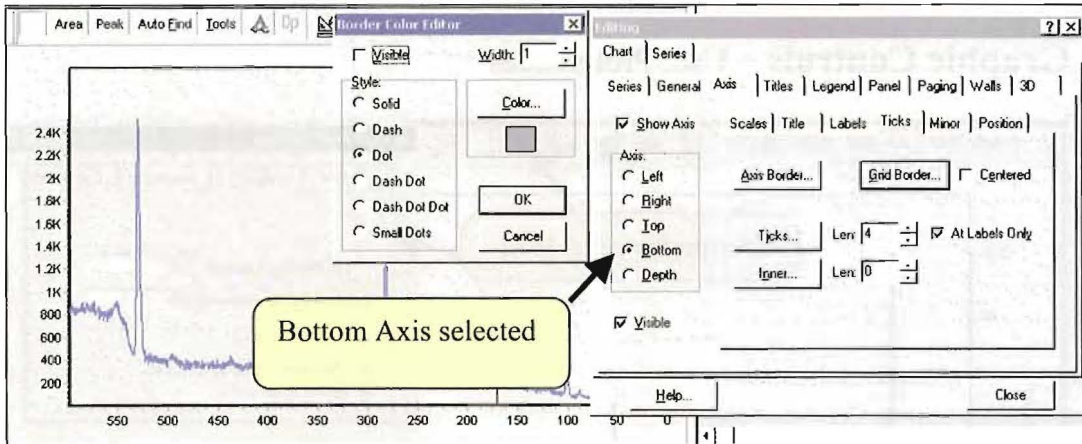

Graphic Controls – User Preferences

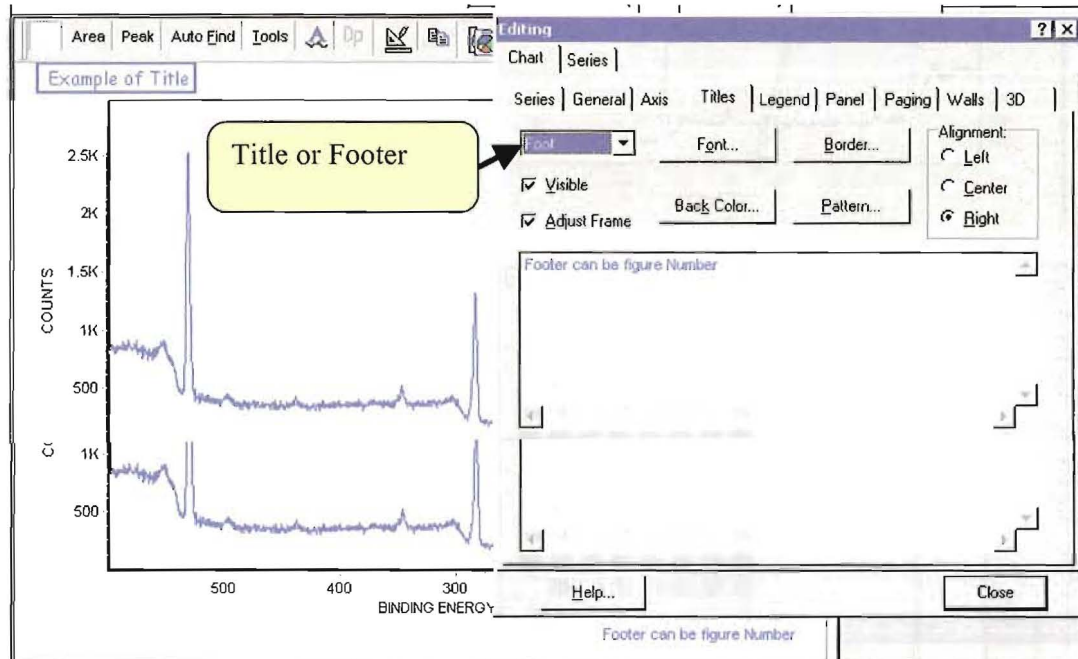
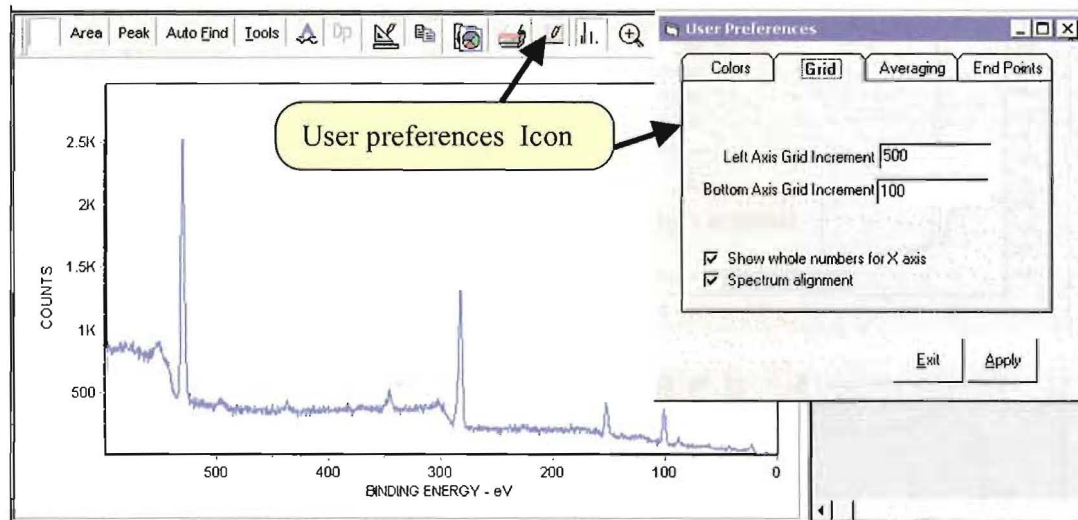

The above sequence shows a few of the capabilities of the Graphic Editor. Many Fonts, font sizes and colors are available. Legends can be created for Graphics with overlays. The panel background can have be a blend of two colors. An depth profiles can be displayed in 3D.

Graphic Control – Print Utility

The General Page of the Graphic Editor provides access to a Print Utility and Graphic Export.

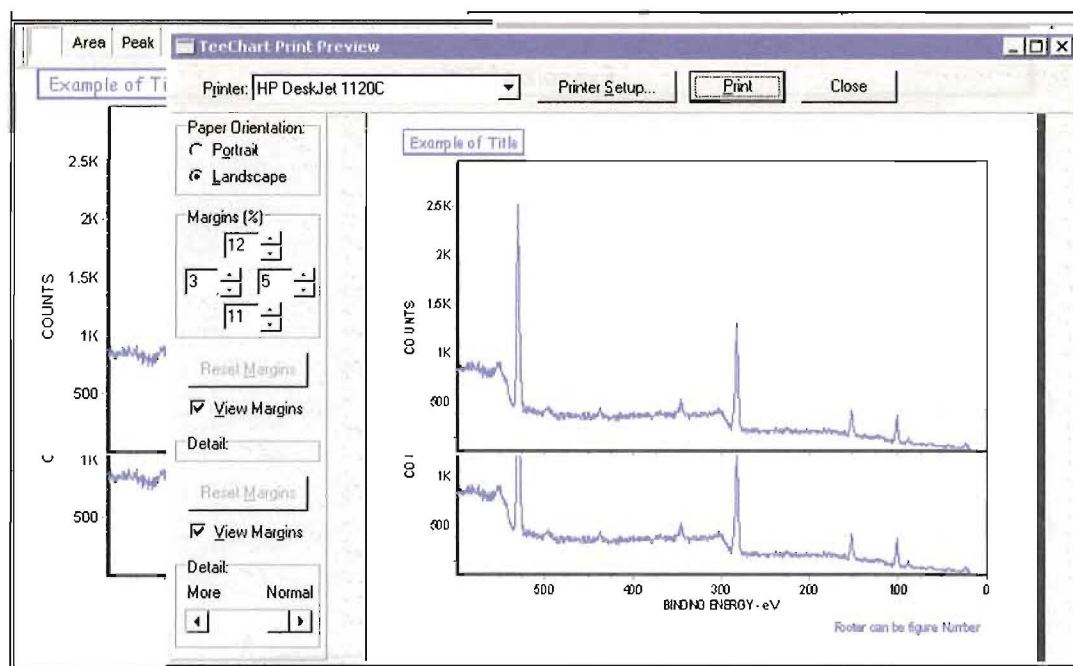
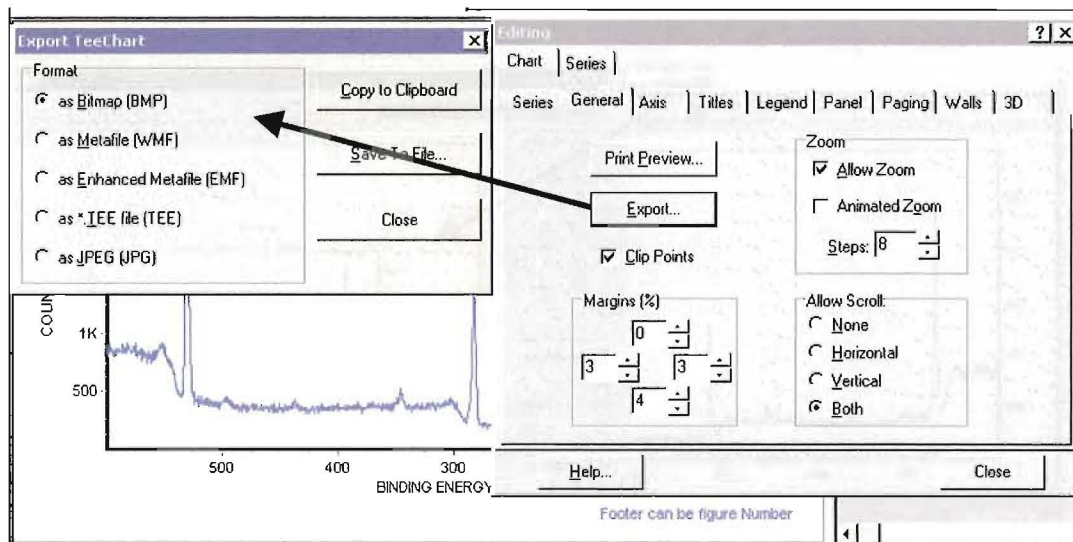

Graphic Control – Print Utility – Cont

The Print Preview can be obtained from the Printer Icon or from inside the Chart Editor. The Chart Editor provides more flexibility. The Printer Icon provides convenience.

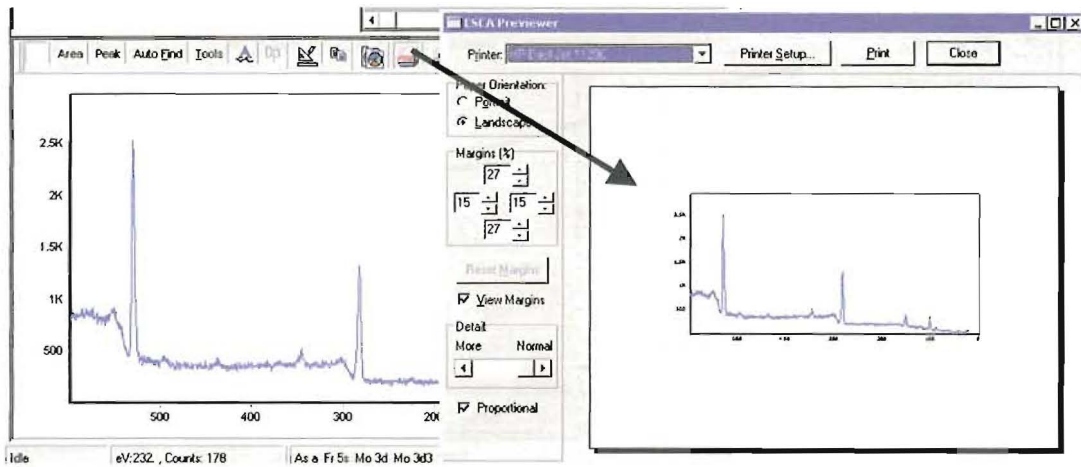

Example of printout form Graphics Editor

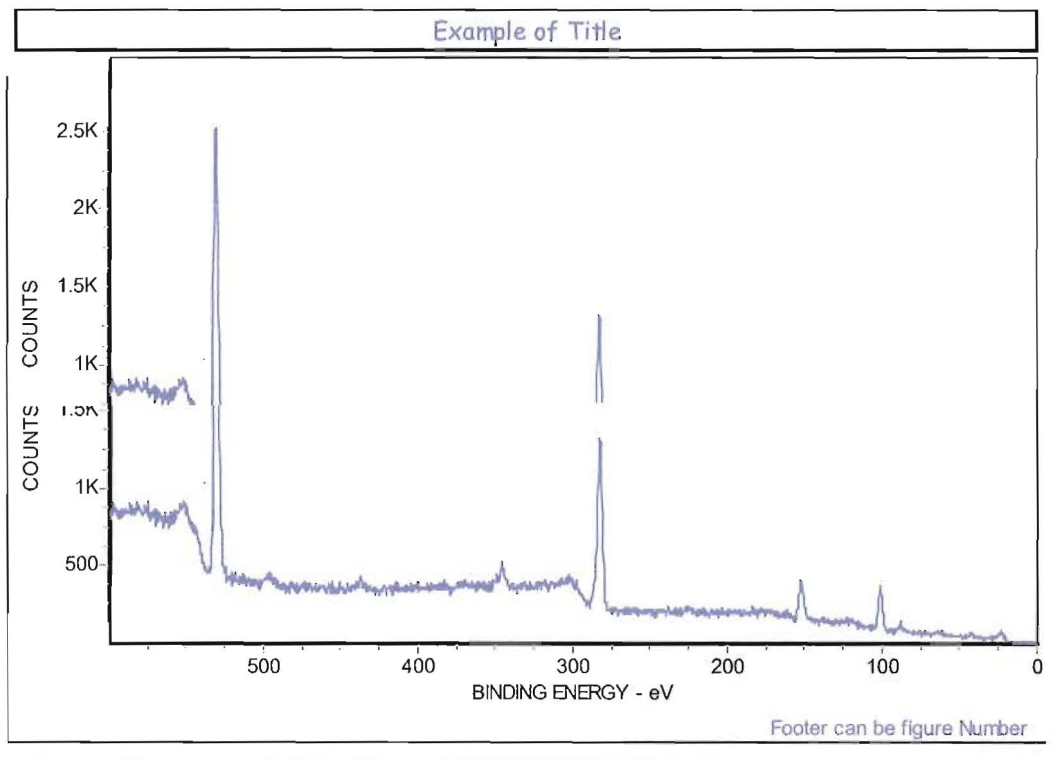

Graphic Control – Spectrum color

The color wheel icon provides access to the “Change Color and Line Style” dialog.

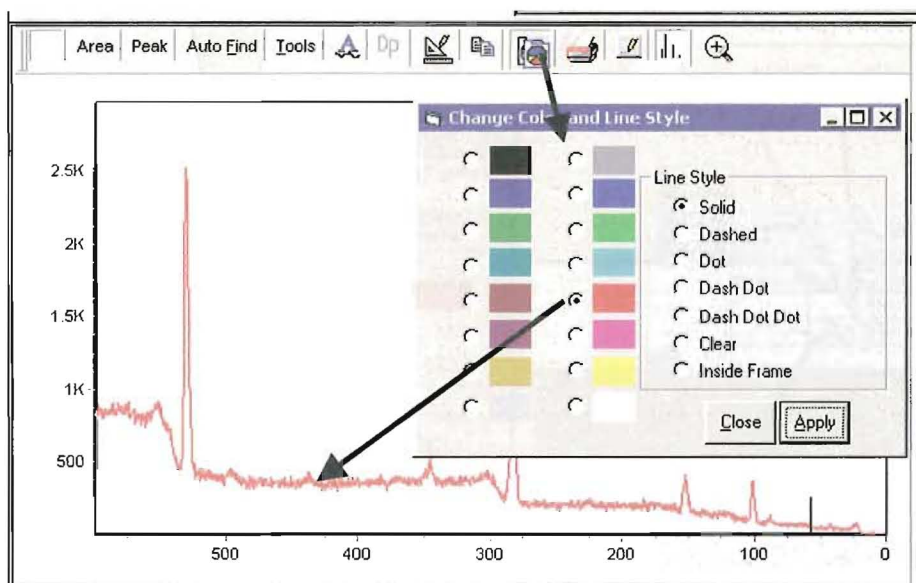

Graphic Control – Clipboard

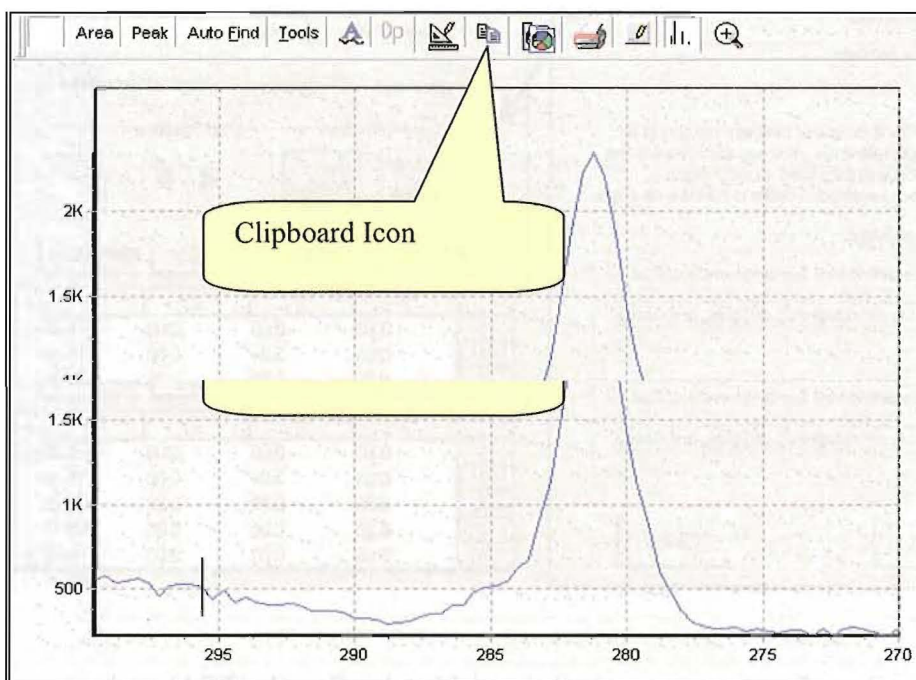

The spectrum displayed in the Graphics Viewer can be placed on the Windows Clipboard by clicking on the Clipboard Icon. The image is available for pasting into any Windows program.

Motion Control –Angle Resolve and tilt stage setup

1. Load Motion Control Pnl

2. Load Position Table

3. Open Angle Setup

MOTION Controls

Motion Controls

Configure Motors | Joystick buttons | Angle Setup | Enable

Home Controls

Rotation | Motors

SET XYZ R | Cont

GOTO XYZ R | Stop | Joystick

Units

XYZ mm | Rotation deg | Goto * or Get

X:10 | Y:2.3 | Z:0.52 | R:33

Tilt Setup

The tilt stage can be loaded with the support bearings on the left or right. Your choice usually depends on the flood gun position. Select a "Support Side".

Choose Support Side

Support on Left

Support on Right

The take-off angle is measured between the axis of the lens and a sample reference. The surface normal or the plane of the surface can be used as the surface reference. Select a method of defining the take-off angle.

Define Take-off Angle

Angle between lens axis and sample normal.

Angle between lens axis and sample surface.

Angle between lens axis and sample normal.

Angle between lens axis and sample surface.

OK | Cancel

Position Table - Multi Recipe

New | Clear | Del | Save > Exit

Table Name | Default

Modes

Positions | Recipes | Joystk step enabled

Get Current Position

Auto add | Get * Position

Update

Step Positions

Pos #

Add Line | Del Line | Move Up | Move Down

	X	Y	Z	R
1	0.00	0.00	0.00	0.00
2	0.00	0.00	0.00	15.00
Add Line Del Line move up move down				
	X	Y	Z	R
1	0.00	0.00	0.00	0.00
2	0.00	0.00	0.00	15.00
3	0.00	0.00	0.00	30.00
4	0.00	0.00	0.00	60.00
5	0.00	0.00	0.00	90.00

The tilt stage allows for computer controlled variable takeoff angle (TOA) analysis. With the Motion Control Panel open select the PT M function and open the Position Table dialog. This will enable the "Angle Setup" button on the Motion Control Panel. Click the "Angle Setup" button on the Motion Control panel to display the **Tilt Setup** dialog.

Motion Control –Angle Resolve and tilt stage setup – cont.

The relationships described in the Tilt Setup are pictured below.

Takeoff Angle

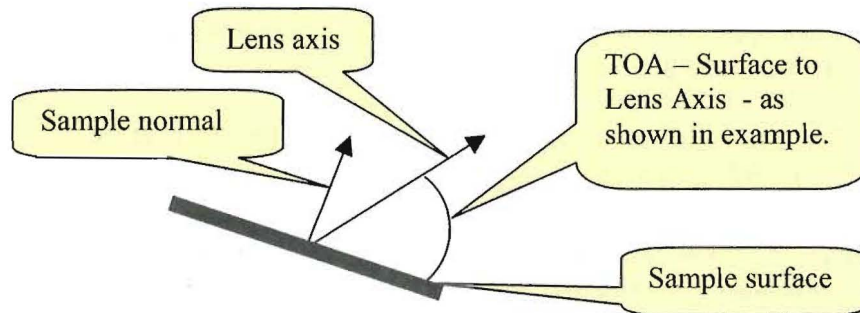

Tilt Stage

Shown with bearing support on right.

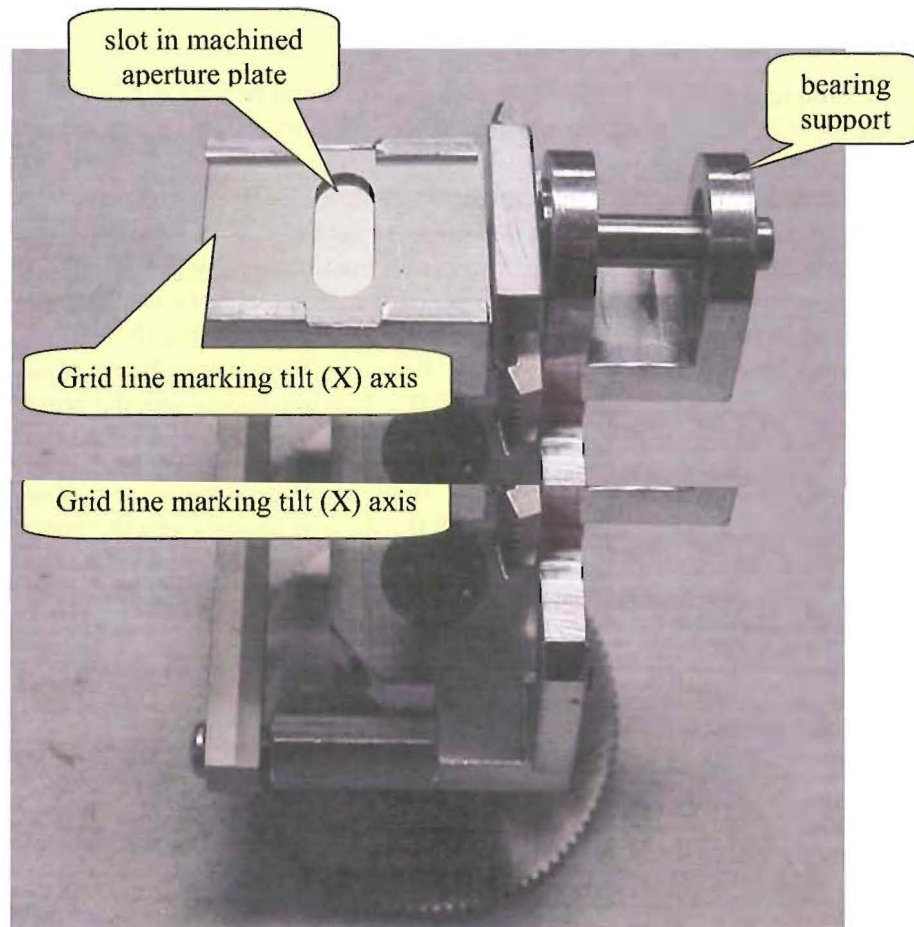

Motion Control –Angle Resolve and tilt stage setup – cont.

The tilt stage allows for variable TOA analysis and by rotating the stage about its X-axis. The TOA can be varied from 0 to 90 degrees. Mount the sample by placing it between the solid bottom platen and the machined aperture plate.

In order for the software to work properly the following conditions must be met; The microscope must be calibrated (refer to the section **Adjusting the Microscope for Correct Sample Registration** on page #17).

Place the sample/stage in the preparation chamber so that the bearing support is located on either the left or right side of the stage.

Lower the Z-axis to the minimum position before transferring the tilt stage to the UHV chamber. This is a precautionary step to avoid collisions of the tilt stage with the hardware that protrude into the analytical chamber (i.e. flood gun, lens, ion gun).

Raise and manipulate the stage and superimpose the microscope eyepiece crosshairs on the grid line of the stage.

This correctly aligns the tilt stage with the X-ray beam and the lens and the R controller will now tilt the stage.

In this example a TOA of 35° (sample surface horizontal or flat) will be initially defined as home (0, 0, 0, 0). An approximate setting of the horizontal is sufficient for this initial setting.

- a Using the unscanned data acquisition mode and a strong elemental line adjust the Z-axis for maximum counts and click on the **SET XYZ Home**(see next page).
- b Now use the Y-axis to move away from the tilt axis (**do not move Z**). If the counts and signal (dot pattern on the detector) remains constant, then the stage is positioned correctly at TAO of 35° (or 55° if using the lens axis to sample normal as the definition of TOA). If not use **R** (low speed) and adjust the tilt for maximum counts and click on **SET R**. This accurately sets the horizontal plane
- c Use **GOTO home XYZ** to return to the tilt axis. Check and refine the alignment of the grid line on the top machined plate so that it overlaps the microscope cross normal as the definition of TOA). If not use **R** (low speed) and adjust the tilt for maximum counts and click on **SET R**. This accurately sets the horizontal plane
- c Use **GOTO home XYZ** to return to the tilt axis. Check and refine the alignment of the grid line on the top machined plate so that it overlaps the microscope cross hair.

Motion Control –Angle Resolve and tilt stage setup – cont.

Aligning Sample for Angle Resolve Analysis

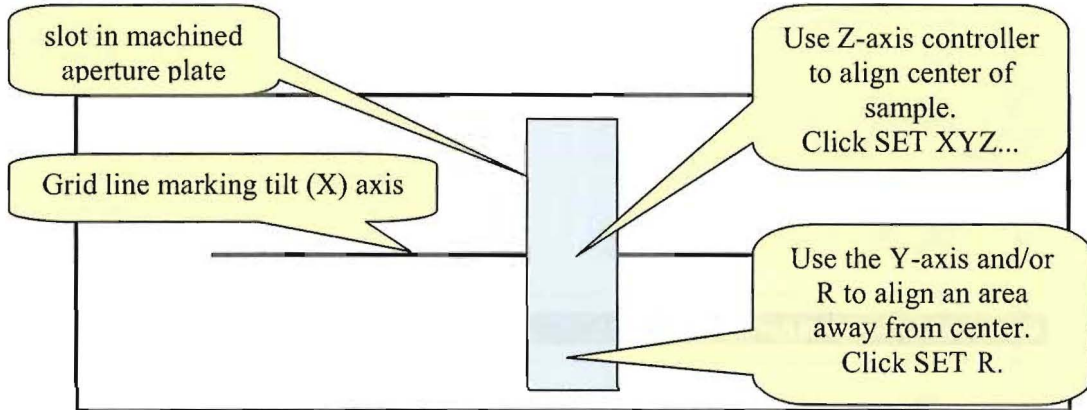

Note angles entered in the R column in the position table on page 42. Enter the set of angles you plan to use in the experiment. Use the add line, delete line etc to organize the table as you choose.

The steps completed to this point are:

1. Select the tile configuration in the Tilt Setup dialog. Close dialog
2. Align the Home condition for the tilt stage as outlined above.
3. With the Motion Control Panel Measurement System set to degrees enter the tilt angles for your experiment.

Now Select the Tilt Measurement System (see pg 42) in the Motion Control Panel. Your input numbers will be converted to Raw motor steps. This conversion will account for the tilt stage gear ratio and the Tilt Setup configuration. The final table is displayed below.

the tilt stage gear ratio and the Tilt Setup configuration. The final table is displayed below.

Motion Control –Angle Resolve and tilt stage setup – cont.

The screenshot displays two parts of the software interface. The top part shows a control panel with buttons for 'GOTO', 'XYZ', 'R', 'Stop', and 'Joystick'. Below these are dropdown menus for 'XYZ' (set to 'mm') and 'Rotation' (set to 'tilt'). A 'Goto * or Get' button is also present. Below the dropdowns are input fields for 'X:-3.39', 'Y:-0.63', 'Z:0.52', and 'R:66'. A yellow callout bubble points to the 'Rotation' dropdown with the text 'Select tilt measurement system.'

The bottom part of the screenshot shows a window titled 'Position Table - Multi Recipe'. It contains a menu bar with 'New', 'Clear', 'Del', and 'Save > Exit'. Below the menu bar is a 'Table Name' dropdown set to 'Default'. Under 'Modes', there are radio buttons for 'Positions' and 'Recipes' (which is selected), and a green indicator 'Joystick step enabled'. There are also buttons for 'Get Current Position' (with 'Auto add' and 'Update' sub-options) and 'Step Positions' (with 'Get * Position' and 'Pos #' sub-options). At the bottom of the control area are buttons for 'Add Line', 'Del Line', 'Move Up', and 'Move Down'. A yellow callout bubble points to the 'Recipes' radio button with the text 'Select Recipe Mode'. Another yellow callout bubble points to the 'Recipe' column of the table below with the text 'Select recipes'.

	Position	Recipe	X	Y	Z	R
1	0 Deg	Position Table Blank:Au re	0.00	0.00	0.00	-16,500
2	15 Deg		0.00	0.00	0.00	-12,000
3	30 Deg		0.00	0.00	0.00	-7,500
4	60 Deg		0.00	0.00	0.00	1,500
5	90 Deg		0.00	0.00	0.00	10,500

The Recipes are assigned by selecting the Recipe Display Mode and selecting the Recipes from the dropdown dialog.

The Recipes are assigned by selecting the Recipe Display Mode and selecting the Recipes from the dropdown dialog.

Motion Control – Enable/Disable Buttons

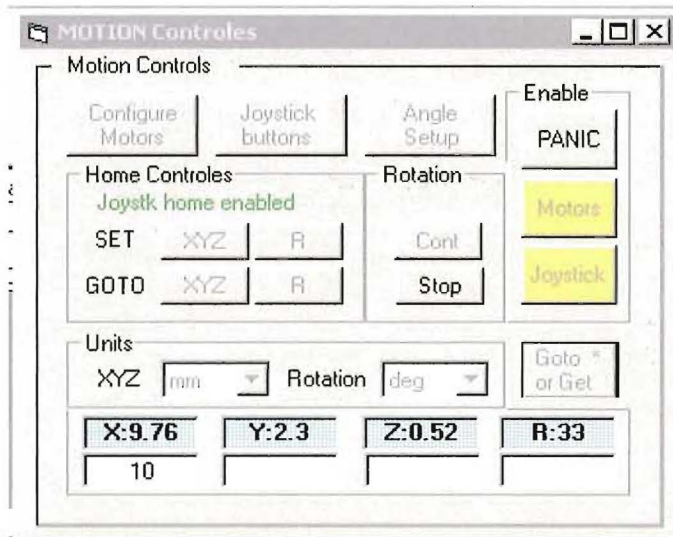

Review the last three screens that show the Motion Control Panel. Notice the Motors and Joystick buttons take on the colors Red, Yellow and Green depending on the state of the Motion control system. Clicking either button will toggle the state of the Motors or the Joystick between enabled and disabled (Green or Red).

1. Disabling the Motors turn the power to the motors off.
2. Disabling the Joystick block Joystick control of the motors.

The yellow state is displayed during computer-controlled movement. Notice that a number of control panel buttons are disabled during computer-controlled motion.

NOTE: If the motion system stops working it is often sufficient to Disable the Motors and then re-enable them to restore normal operation. Your Home position will not be lost.

Motion Control – Home controls

Motion Control – Home controls

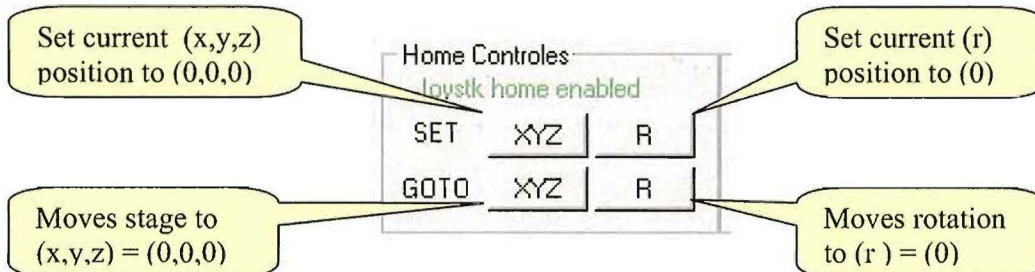

The GOTO R button causes the rotation position to return to 0 deg or 360 deg.

Motion Control –Mode control of the Joystick buttons (6K4).

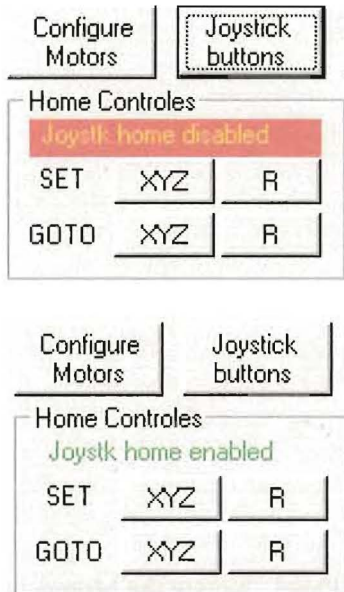

Clicking the “Joystick buttons” button toggles the function of the two front buttons on the Joystick. When the Joystick home is enabled, then the left front button set the current XYZ position as home. Likewise, the right front button will set the current rotation position as home. This is very convenient for initially setting a home position while observing the sample with the microscope.

Later, when reviewing the learned sample positions, the mode can be switched. When the home function is disabled in the Motion Control Panel then the Joystick Step Next/ Step Back Function is enabled in the Position Table.

JOYSTICK CONTROL BOX – USB model

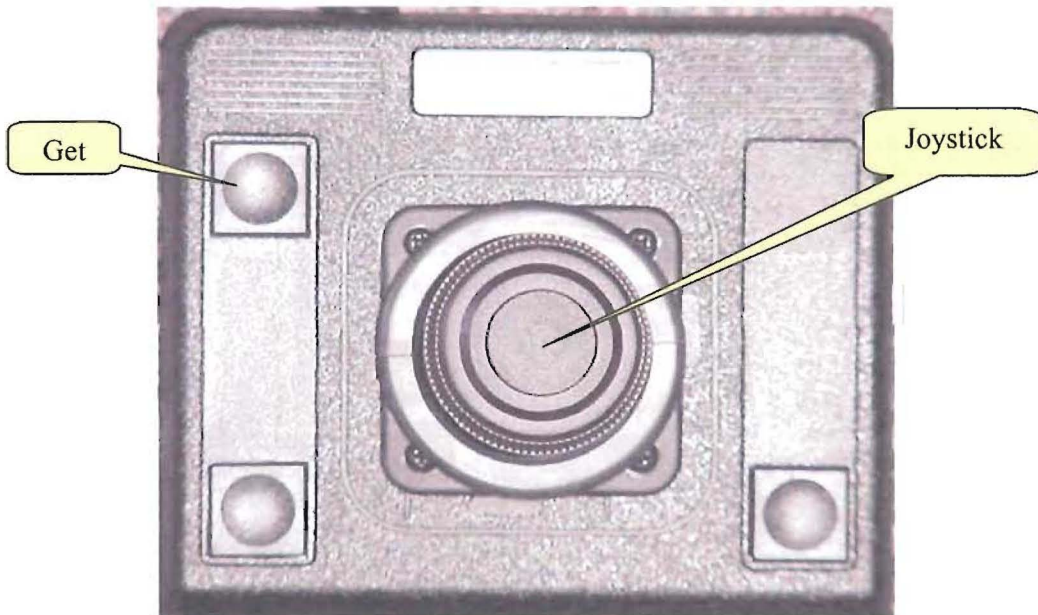

<u>XYZ</u>	<u>Set Home</u>	<u>R</u>
Back	Step Position	Next

The joystick controls motion along the X (left/right), Y (forward/back) and “Z axes (press center button while moving the Joystick forward-back). Rotation is obtained by twisting the outer ring clockwise/counter clockwise.

The Get function “Gets “ the current coordinates and fills or updates in the position cell in the position table.

Motion Control – Panic Button

The PANIC button is used to immediately stop all motion!

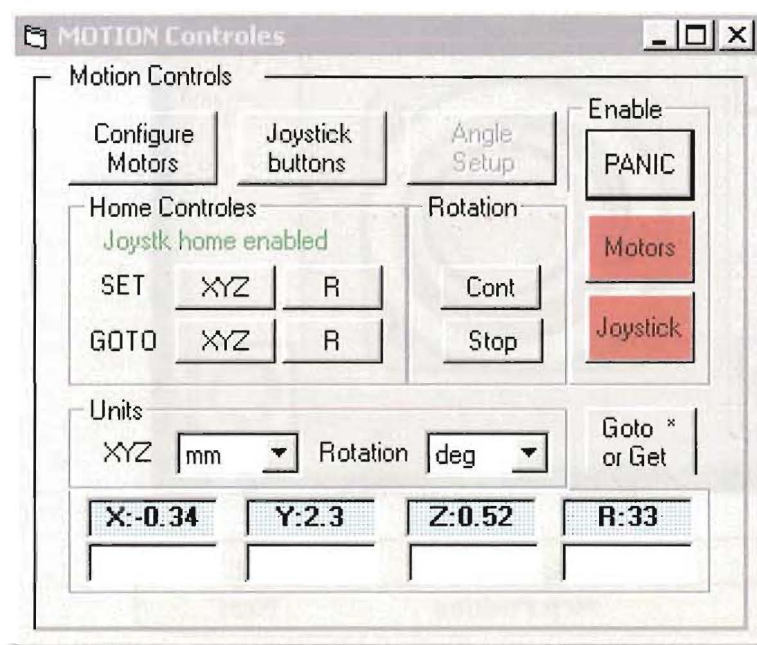

All motion is stopped and power is removed from the motors. The current home location is not lost.

To restore normal operation select the Motor button and then the Joystick button. After both buttons turn green, the Motion system will be ready for operation

Motion Control - Position Table Setup

Setting up the **Position Table** disables **Recipes** so, when possible, compose **Recipes** beforehand.

Use the **Function** pull down menu and select **PT M**. Then click the design button (“The Pencil”) Icon. This activates the **Position Table – Multi Recipe Panel**. If the Motion Control Panel is not open it will be opened along with the Position Table.

The screenshot displays the Esca Capture software interface. The main window shows a list of functions in a table:

Function	Recipe	Positions
Survey		1,2
ResHi		
H5Scan		
UnScanned		
Depth Profile		
IDSystem		
Etch		
Neutralizer		
Label		
BLoop		
XPause		

Callouts identify the 'PT M Function' in the list, the 'Design Icon "The Pencil"' (a pencil icon), and the 'Position Table – Multi Recipe Panel' which is open on the right. The panel includes fields for 'Table Name' (Default), 'Modes' (Positions selected), and a table for step positions:

	X	Y	Z	R	A
1	0.00	0.00	0.00	0.0	

The 'Motion Controls' panel is also visible, showing 'Home Controls' with 'SET XYZ R' and 'GOTO XYZ R' buttons, and 'Rotation' controls with 'Cork' and 'Stop' buttons. A graph at the bottom shows a signal trace over a range of 1000 to 0.

Set Home

Go to the microscope and set the cross hair on the axis of rotation. Go to the **SET** row of the **MOTION Controls Panel** and click on **XYZ**.

Move toward the edge of the holder, preferably the first sample. **SET** this position as Home for **R**. An initial reference co-ordinate system is now set that can be reproduced if there is a glitch.

Motion Control - Position Table Setup cont.

Learning Positions

There are two modes of adding rows to the position table. They are controlled by the radio buttons in the Get Current Positions frame.

1. Select the Update mode. Each time the Add Line button, on the position table form is clicked, a blank row will be added to the table. When the Get Position button is clicked the values for each axis will be updated.
2. Select the Auto Add mode. Rows are added and filled in each time the Get Position button is selected.

The Update mode is convenient for updating or refining the coordinates for an existing table. The Auto Add mode is best when building a table from scratch.

NOTE: The Joystick Get Position button works the same as the button on the form. With Auto Add selected, you can learn all your positions without going back to the computer.

Choose one of the above modes of operation. Put the cursor on the X axis cell of the first row. Row (1). The X axis cell is arbitrary but a good practice. With the stage aligned on position, (Pos 1) click the Get Position button on the Joystick or on the Position table form. The Special Function button is the Get Position button for the old Joystick. If you chose the Update mode the coordinate cells of row (1) will be filled. If you chose the Auto Add mode then you will have a new row at the bottom of the table with the values for the current position.

In the update mode, you will continue to put the cursor on the X column of the row that matches your sample. You will move to a new position and select the Get Position button.

In the Auto Add mode you will continue moving to new positions and selecting the Get Position button. When you are finished, delete any rows left over from previous tables. You will then be left with a table properly numbered.

In the Auto Add mode you will continue moving to new positions and selecting the Get Position button. When you are finished, delete any rows left over from previous tables. You will then be left with a table properly numbered.

The screen on the next page shows the controls discussed.

Motion Control - Position Table Setup cont.

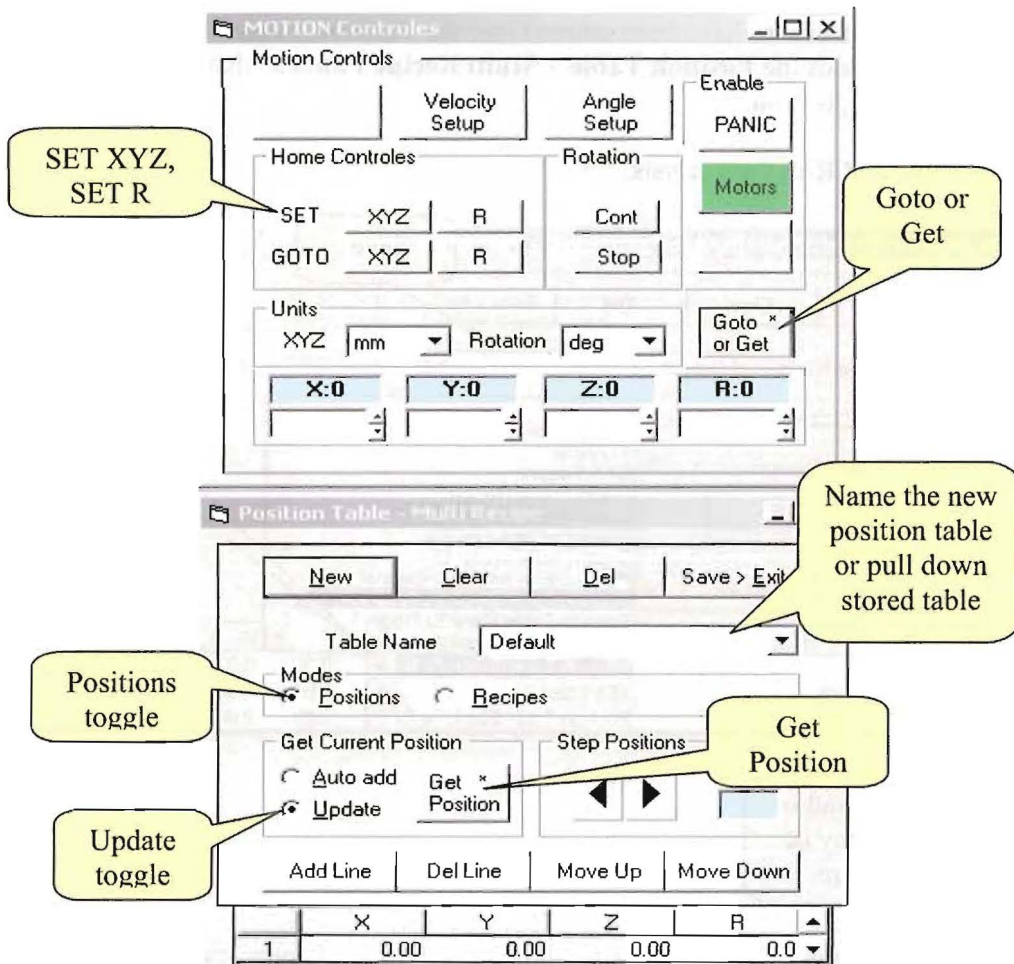

NOTE: With the GPIB/2100 Indexer system the Joystick operation is not connected to the computer. Continuous polling of the Indexers to see if there has been Joystick activity leads to less reliable operation. The “Goto or Get” button on the Motion Control Panel is used to request current stage position. This provides the required update. The Motion Control Panel button ONLY updates the Motion Control display. The Get Position Button on the Position Table and the Joystick update both the Motion Control Panel and the Position Table.

Motion Control - Position Table Setup cont.

After the desired positions have been entered into the **Position Table** click on the **Recipe** button. This expands the **Position Table – Multi Recipe Panel** so that Recipes may be assigned for each position.

Save the table and **Run** the analysis.

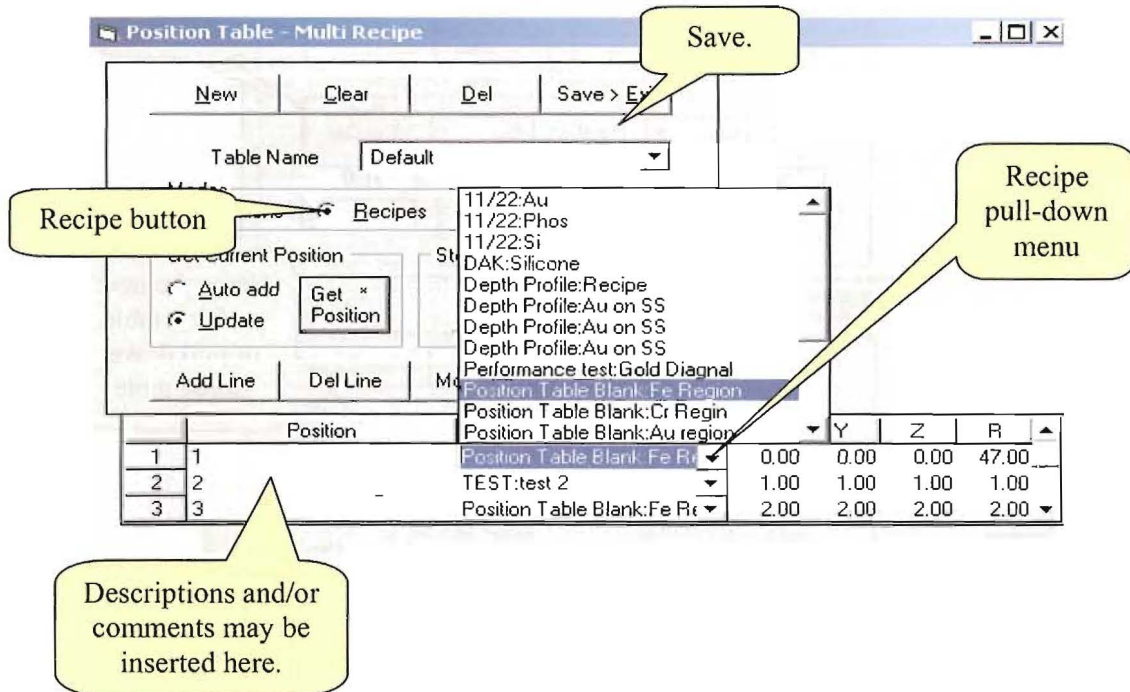

If, after acquiring the data set, more data is needed, create the appropriate Recipes and insert them into the previous position table. Then **Save** again.

Previously stored position tables may be reused and edited to accommodate different sets of samples.

Previously stored position tables may be reused and edited to accommodate different sets of samples.

Motion Control - Rotation

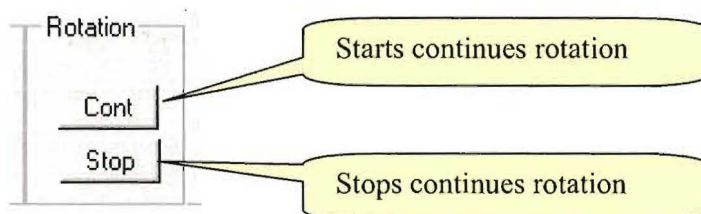

Motion Control – System configuration.

The image shows two windows from the MOTION Controls software. The top window, titled "MOTION Controls", contains several control panels: "Motion Controls" with buttons for "Configure Motors", "Joystick buttons", "Angle Setup", and "Enable"; "Home Controls" with a red "Joystick home disabled" message and buttons for "SET", "GOTO", "XYZ", and "R"; "Rotation" with "Cont" and "Stop" buttons; "Units" with dropdowns for "mm" and "deg"; and a "Goto * or Get" button. Below these are input fields for "X:-0.34", "Y:2.3", "Z:0.52", and "R:33". The bottom window, titled "Establish Motor Configuration", prompts the user to select a motion control interface: "None", "2100 Indexers with HPIB", or "6K4 with Ethernet" (which is selected). It also prompts to check installed axes, with a list showing "X Axis", "Y Axis", "Z Axis", and "R Axis" all checked. A "Store Selection and Exit" button is at the bottom.

1. No Motors then use "None"
2. National GPIB card us 2100 Indexers with HPIB.
3. New motion system use 6K4.

On new installations, check all installed axes.
If a fault message suggests you should uninstall a motor, remove the check for the reported axis.

should uninstall a motor, remove the check for the reported axis.

This configuration dialog will be displayed when the software is first installed. Your responses will be stored in the registry.

Motion Control – Units, coordinates.

The screenshot shows a software interface for motion control. At the top, there are dropdown menus for 'Units' (set to 'XYZ') and 'Rotation' (set to 'deg'). A 'Goto * or Get' button is located to the right. Below these are input fields for coordinates: 'X:10', '2.3', 'Z:0.52', and 'R:33'. A callout bubble points to the 'R:33' field, stating 'Read only - Current position'. Another callout bubble points to the 'X:10' field, stating 'Manual entry - (X,Y,Z,R)'. The 'X:10' field has a dropdown menu open showing 'mm', 'inch', and 'raw' options.

XYZ Scale units are:

1. mm = millimeters
2. inch = inches
3. raw = number of motor steps (250,000 / inch)

R Scale units are:

1. deg = degrees
2. raw = number of motor steps (36,000 / turn – 6K4 or 25,000 / turn GPIB)
3. tilt = converts TOA (Take Off Angle) to raw. See Motion Control – Angle Resolved.

Enter position coordinates and then click Goto (or keyboard Enter) for manual control. If no position coordinates are entered (i.e. White boxes are empty) then the current motor positions will be recovered from 2100 Indexers. This is not required with 6K4.

Motion Control – Velocity Setup (GPIB with 2100 Indexers only)

The **Velocity Setup** only controls the velocities for computer, not joystick control.

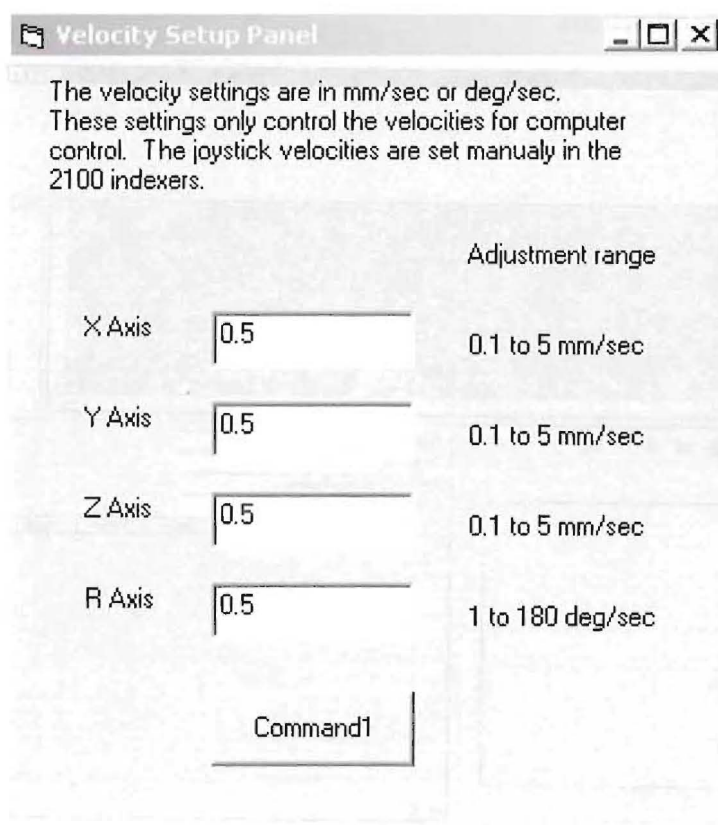

The screenshot shows a window titled "Velocity Setup Panel" with standard Windows window controls (minimize, maximize, close). Below the title bar is a text box containing the following instructions:

The velocity settings are in mm/sec or deg/sec.
These settings only control the velocities for computer control. The joystick velocities are set manually in the 2100 indexers.

Below the text is a table with four rows, each representing an axis. Each row has a label on the left, a text input field in the middle, and an "Adjustment range" on the right. The input fields all contain the value "0.5".

		Adjustment range
X Axis	0.5	0.1 to 5 mm/sec
Y Axis	0.5	0.1 to 5 mm/sec
Z Axis	0.5	0.1 to 5 mm/sec
R Axis	0.5	1 to 180 deg/sec

At the bottom of the panel is a text input field labeled "Command1".

MRS Tables

A capture screen, with a new database loaded, will show no MRS table. Select a Recipe to load the MRS table constructor functions.

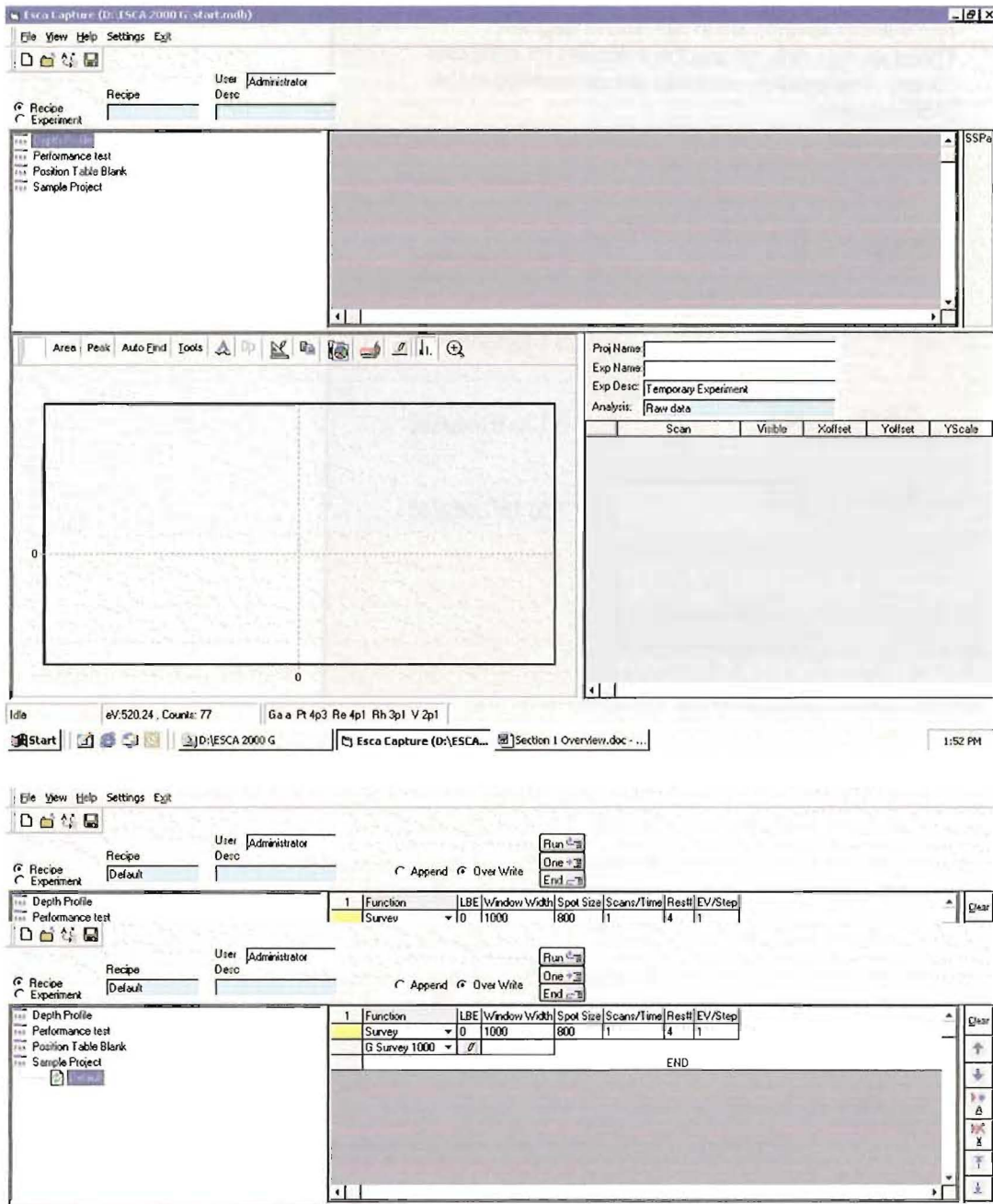

In this case the Sample Project > Default Recipe was selected. The MRS for this Recipe is a simple survey. We can start from this MRS and modify it to create the parameter table for the Spectrum capture desired. First, a review of the possibilities.

MRS Tables - Construction by selecting and editing Functions.

Adding a new function.

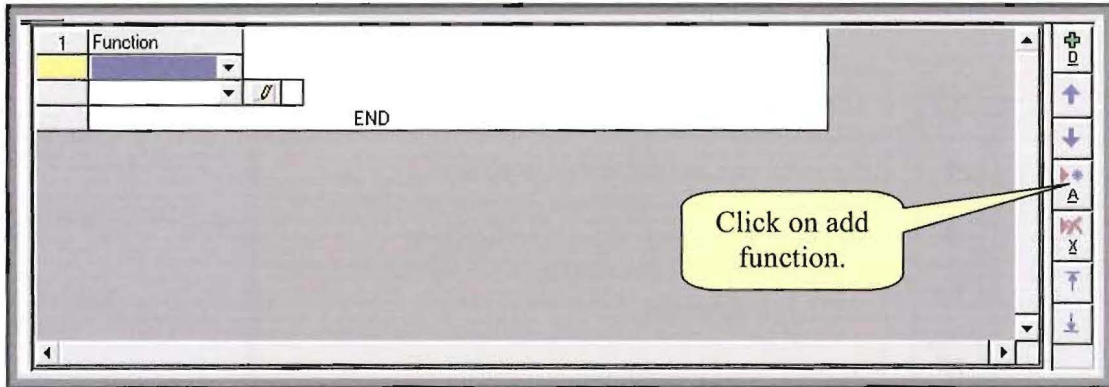

Drop down the Function menu

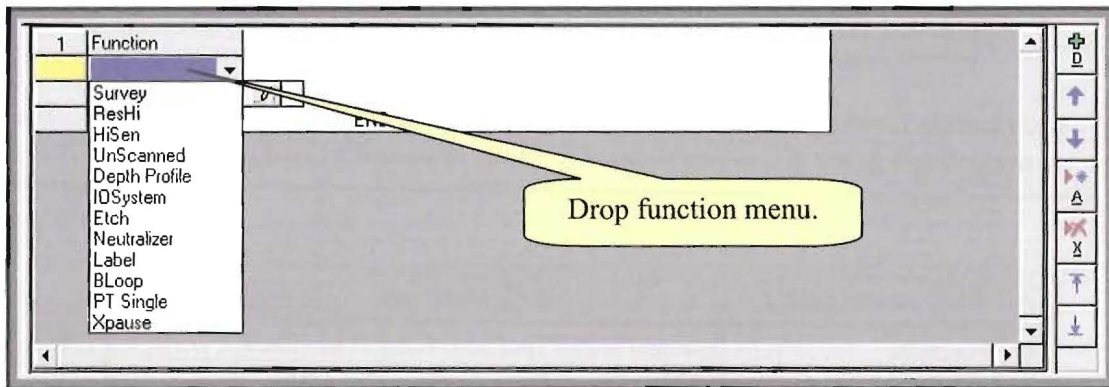

Select a Function

1	Function	LBE	Window Width	Spot Size	Scans/Time	Res#	EV/Step
	Function	n	1000	800	1	4	1

Select a Function

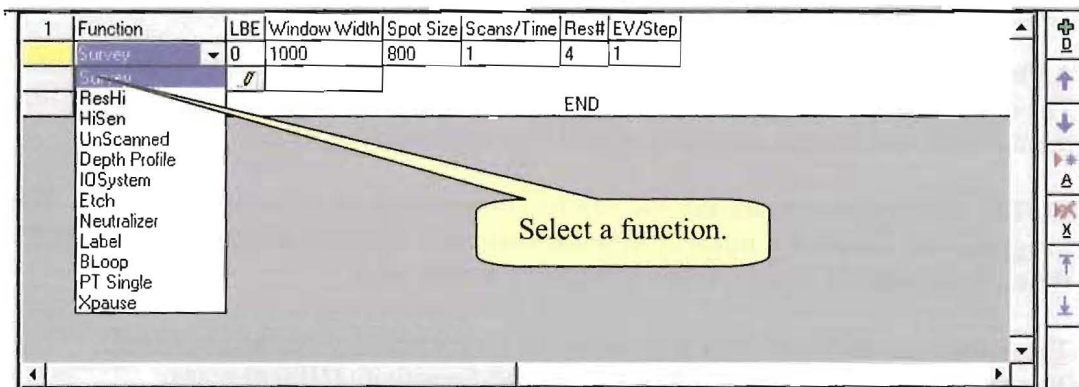

MRS Tables – Construction buy editing Functions cont.

FUNCTION TABLE CONTROLS

Clear	Clear MRS table. Leaves top function.
↑	Set next row up the active function
↓	Set next row down the active function
▶* <u>A</u>	Add new function
✕ <u>X</u>	Delete current function
↑	Move current function up one row
↓	Move current function down one row

The controls for the manipulation of the functions in the table are described above. The **underlined A** and **X** can be executed from the keyboard by using Alt-A or Alt-X.

1	Function	LBE	Window Width	Spot Size	Scans/Time	Res#	EV/Step
	Survey	0	1000	800	1	4	1
	G Survey 1000	/					

A **Function** (in this case a **Survey**) creates a list of default data acquisition parameters.

A **Function** (in this case a **Survey**) creates a list of default data acquisition parameters. The default values are often ok but it is quick to customize the values. For example, the number of **Scans** is often increased or the BE conditions are changed.

NOTE: Time, stated as hh:mm:ss, can be entered instead of number of scans. The program will compute a number of scans that most closely matches the requested time. A calculation of zero scans will be run as one scan.

The default parameter eV/step is set optimum for the selected resolution (Res#). This applies to high resolution (ResHi) and high Sensitivity (HiSen) scans.

MRS Tables - Construction by editing Functions cont.

NOTE: TAB or the mouse must be used to step out of the **Function** column.
 In the **Function** column the arrow keys move up and down the **Function** list and not from **Function** to parameter columns or **Function** to **Function**.
 The arrow keys move up and down or side to side in the parameter columns.
SHIFT TAB will tab right to left. It is fast to fill in a table and then “arrow” down the scan column and set the number of scans at one time.

High Resolution scans and High Sensitivity scans may be added to the table as required by the analysis. For these two cases the binding energy is changed from the default values. This is quickly accomplished by “Arrowing” down the BE column.

1	Function	LBE	Window Width	Spot Size	Scans/Time	Res#	EV/Step
	Survey	0	1000	800	2	4	1
	G Survey 1000	/	Survey				
2	Function	CBE	Window Width	Spot Size	Scans/Time	Res#	EV/Step
	ResHi	284	20	300	5	2	0.065
	G HR R2	/	C 1s				
3	Function	CBE	Window Width	Spot Size	Scans/Time	Res#	EV/Step
	ResHi	530	20	300	3	2	0.065
	G HR R2	/	O 1s				
4	Function	CBE	Window Width	Spot Size	Scans/Time	Res#	EV/Step
	ResHi	100	20	300	5	2	0.065
	G HR R2	/	Si 2p				
5	Function	CBE	Window Width	Spot Size	Scans/Time	Res#	EV/Step
	ResHi	348	20	300	10	2	0.065
	G HR R2	/	Ca 2p				

Region name

The above **Multi Region Scan (MRS)** has a survey and four high resolutions Region. Each region has been named for ease of identification. The region name will default to Region 1, Region2 etc if the names are not entered.

MRS Tables - Run Controls

Append Over Write

Run
One
End

Run button

1	Function	LBE	Window Width	Spot Size	Scans/Time	Res#	EV/Step
	Survey	0	1000	800	2	4	1
	G Survey 1000		Survey				
2	Function	CBE	Window Width	Spot Size	Scans/Time	Res#	EV/Step
	ResHi	284	20	300	5	2	0.065
	G HR R2		C 1s				

Proj Name: _____
 Exp Name: _____
 Exp Desc: Temporary Experiment
 Analysis: Raw data

Before running the MRS table a Project Name and Experiment Name must be provided. These two names taken together create a unique identity for the MRS in the database. The Experiment Description is for additional information that makes clear the Experiment. The description is not used for finding the data. It is supplied after the data is recovered.

Most of the time there will be a Project Name and Experiment Name in the input boxes. These names will be left from the previous state of the Capture Program. It is most likely you will not change the Project Name. This assumes that you will do many Experiments for one Project. The typical operation will be to write over or modify the Experiment Name. You may add letters or numbers to show a sequence in the experiments.

After taking care of the Project Name, Experiment Name and Description Select a Run Control.

Control.

Three **Run Controls** are found above the **Function Table**. The lines in the **Function Table** can be run to capture a sequence of regions. The **Run** button runs the complete **Function Table** from line 1 to the bottom of the table. The second button labeled **One** only runs the current active (highlighted) line. The bottom button labeled **End** runs from the current active line to the bottom of the **Function Table**. Once a capture is started additional buttons appear to control termination.

Pause, Stop , Abort and **Append** buttons appear to the right of the three run buttons.

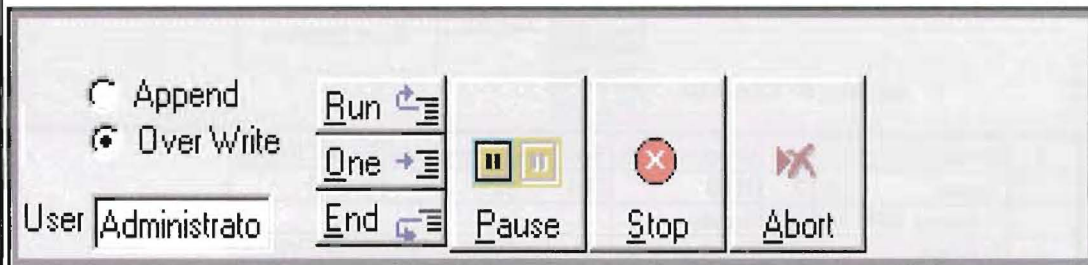

Pause – MRS tables. Pause will temporarily stop the capture so a change can be made to the number of scans or capture time. In order to continue, click again on Pause.

Pause – Depth Profiles. Pause will temporarily stop the capture of a scan. During the pause the etch time or number of cycles may be changed. In order to continue, click again on Pause. If Pause is used during the etch cycle the current etch cycle will finish and then the Pause will be executed.

Pause – Position Tables. Pause will effect the MRS table of the current position.

Pause – Ion Etch, The stand alone Etch function will pause during the etch. The etch time can be changed.

Stop – MRS Table. “Stop” is used to stop a scan at the nearest endpoint. If the capture is unscanned then the capture will stop immediately.

Stop – Depth Profiles. “Stop” acts as an abort during a the Depth Profile.

Stop – Position Tables. “Stop” will stop the Position Table MRS at the end of the running spectrum. The Position table will be aborted.

Abort stops all operations immediately. The data taken up to the time of the **Abort** is saved.

Abort stops all operations immediately. The data taken up to the time of the **Abort** is saved.

Append : Normal operation is Overwrite. If a new experiment name is not entered, then the re-run of the current experiment overwrites the existing data. If you want to collect additional data under the current experiment name then you may use the Append mode. This can be used to add a new region to the experiment or to collect additional data for one or more regions. The Appended data may easily be added to the original data by using the Add Spectra function in the Tools menu. The Append mode reverts back to the overwrite mode after the Appended data has been collected.

MRS Tables - Run display

The data being acquired will be visible in the **Spectrum Viewer**.

During data acquisition binding energies may be measured by placing the cursor on the peaks, their binding energies can be seen below in the **Display Bar**.

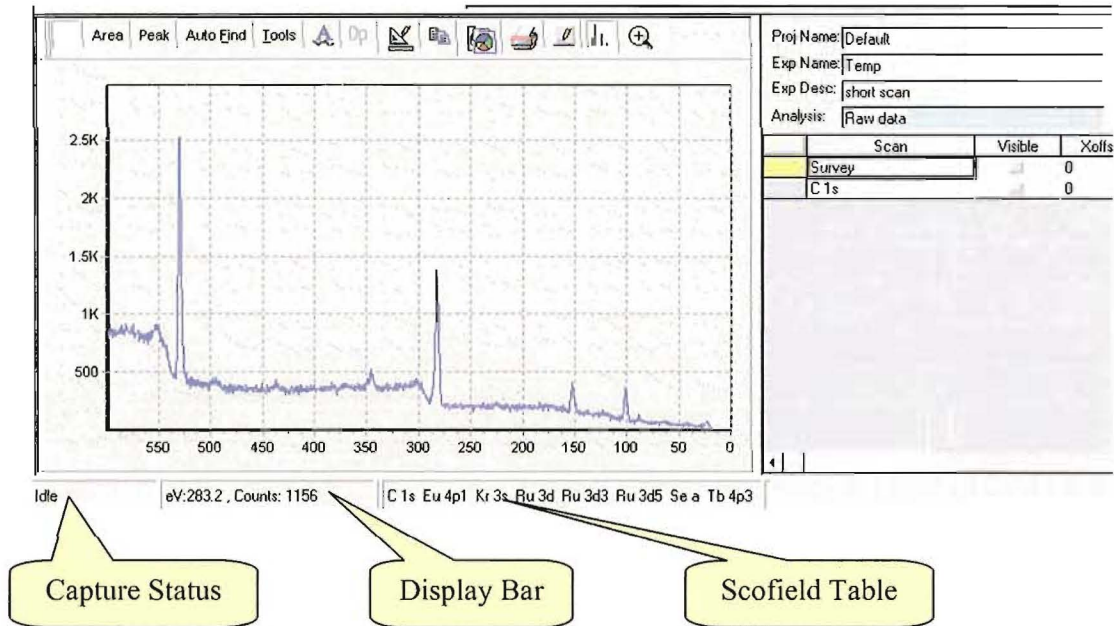

The **Spectrum Viewer** is used to display the current active spectrum and it will always be displayed in this window during data acquisition.

Below the **Spectrum Viewer/ Document Control** area is a display bar that shows the status of the capture process.

During a capture the **Idle** indicator will switch to **Running**.

The information inside of the parenthesis will show the **Recipe** that is being run.

Additional parameters of the capture will also be displayed in this window.
 status of the capture process.

During a capture the **Idle** indicator will switch to **Running**.

The information inside of the parenthesis will show the **Recipe** that is being run.

Additional parameters of the capture will also be displayed in this window.

The next window in the **Status Bar** displays the cursor parameters.

The third window displays the **Scofield Table** showing probable peak assignments as a function of cursor position.

Next section is Data Analysis

The data analysis provide for Compositional Analysis, Peak Fitting, Depth Profile analysis and other data manipulation.

To open the Data Analysis from the Capture program Click on **View > Data Reduction**.

The screenshot displays the ESCA Capture software interface. A yellow callout box highlights the 'Data Analysis button' in the 'View' menu, specifically pointing to the 'Data Reduction' option. The main window shows a data table with columns: Function, LBE, Window Width, Spot Size, Scans/Time, Ret# and EV/Step. The data rows are: Survey (0, 600, 800, 1, 4, .4) and G Survey 1000 (7). Below the table is a plot showing a spectrum with a y-axis from 0 to 2.5K and an x-axis from 650 to 0. The plot shows a sharp peak at approximately 510 eV and a smaller peak at approximately 285 eV. To the right of the plot is a metadata section with fields for Proj Name (Default), Exp Name (Temp), Exp Desc (photo scan), and Analysis (Raw data). Below this is a table with columns: Scan, Visible, Xoffset, Yoff.

Scan	Visible	Xoffset	Yoff
Survey	0	0	0
Cl t	0	0	0

At the bottom of the window, the status bar shows 'Idle', 'eV:265.2, Counts: 197', and 'As a Cl2s Fr 4f Sm 4p1'. The taskbar at the very bottom shows the Start button, system tray icons, and open applications including 'D:\ESCA 2000 G', 'Esca Capture (D:\ESCA...', and 'Section 1 Overview.doc - ...'. The system clock shows '5:09 PM'.