

Pressure Relief Valve Exhaust Connections



WARNING

If toxic, corrosive, or flammable gases are pumped, a vent line must be connected to the On-Board *IS* Cryopump pressure relief valve and directed to an appropriate exhaust gas system.

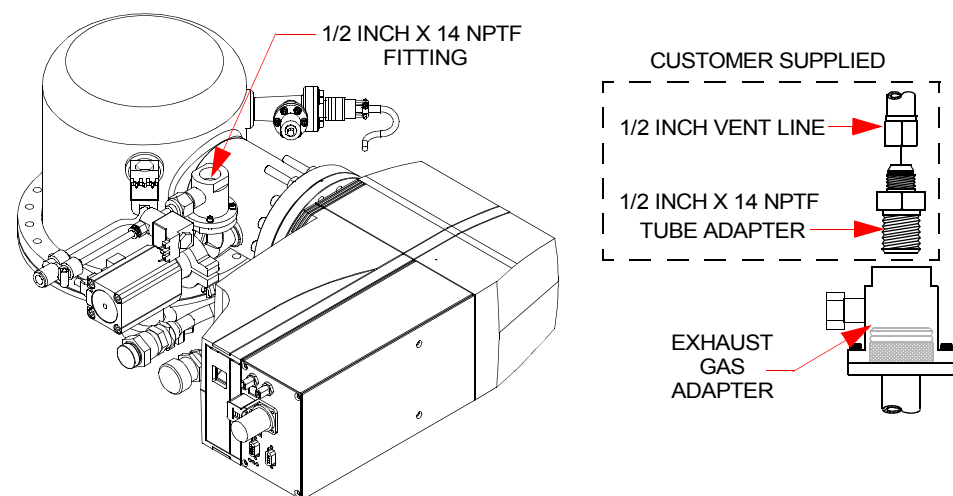

Figure 2: Pressure Relief Valve Exhaust Connections

Helium Flex Line Connections



CAUTION

Make sure the helium flex lines are connected and disconnected using the method shown in Figure 1, Detail B. Failure to follow this method could damage connector O-ring seals or cause a helium circuit leak.

NOTE: Your installation (number of pumps per On-Board *IS*-1000 Compressor) will vary based upon the Cryopump models used. Consult your local CTI-CRYOGENICS Customer Support Center for information on specific compressor/pump applications.

Input Power Connections



WARNING

Make sure the On-Board *IS* Cryopump Power Cable is connected to a 208 VAC, Single-Phase 5 Amp source according to all local electrical codes.

1. Refer to Figure 1, Detail A and connect the Input Power Cable to a 208 VAC source.
2. Insert a flat blade screw driver into the input power connector on the On-Board *IS* Cryopump Module as shown in Figure 1, Detail A.
3. Lift the locking tab in the direction of the arrow shown in Detail A to allow the Input Power Cable connector to be secured to the input power connector on the module.
4. Attach the Input power cable to the module connector and rotate the connector collar until tight.
5. Lower the locking tab to secure the Input Power Cable connector collar.

NOTE: The On-Board *IS* Cryopump is energized once the input power cable has been connected.

Startup

1. Refer to the **On-Board *IS* Cryopump System Operation Guide**, Helix P/N 8040647 to start the On-Board *IS* Cryopump System and perform a Full regeneration cycle.

HELIX

On-Board® *IS* 8F Cryopump Quick Installation Guide

P/N 8040644 Rev. 12 (01/26/04)

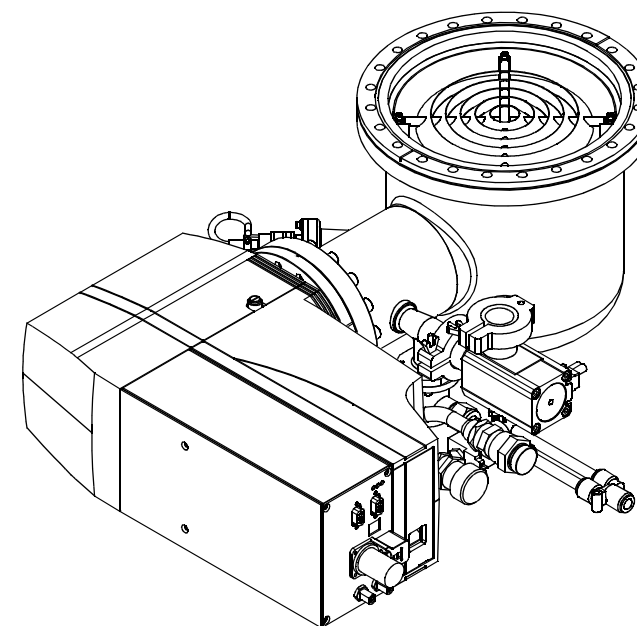

ON-BOARD *IS* CRYOPUMP FACILITY REQUIREMENTS

ELECTRICAL POWER
 208 VAC (RANGE: 180-253 VAC)
 5 AMPS
 50/60 HZ
 SINGLE PHASE

NITROGEN PURGE GAS
 3/8 INCH TUBE CONNECTION
 60 PSIG MINIMUM
 80 PSIG MAXIMUM

ROUGHING VALVE
 N/NW-25 ISO KF FLANGE
 1/8 INCH TUBE CONNECTION
 AIR SUPPLY 60 - 80 PSIG
 1/4 INCH TUBE CONNECTION EXHAUST PORT

HELIX TECHNOLOGY CORPORATION
www.helixtechnology.com

Before You Start

1. Read the Cryopump Safety section and follow all safety precautions.
2. Make sure the On-Board IS-1000 Compressor has been installed according to the directions found in the **On-Board IS-1000 Compressor Quick Installation Guide**, Helix P/N 8040645.

Cryopump Safety

On-Board products have been designed to provide extremely safe and dependable operation when properly used. Safety precautions must be observed during normal operation and when servicing the On-Board system.

NOTE: Read this manual and follow these safety guidelines before installing, operating or servicing On-Board products.

- 
1. Always vent toxic, corrosive, dangerous gases, or liquids to a safe location using an inert purge gas.
 2. Clearly identify toxic, corrosive, dangerous gases, or liquids on containers used to store or ship equipment after such exposure.
 3. Always vent flammable or explosive gases to a safe location using an inert purge gas.
 4. Do not install a hot filament type vacuum gauge on the high-vacuum pump side of the isolation valve. This could be an ignition source of flammable gases in On-Board products.
 5. Disconnect the high vacuum pump system from all power sources before making electrical connections between system components or before performing troubleshooting and maintenance procedures.
 6. Do not modify or remove the pressure relief valves, either on the On-Board pump or within the helium compressor.
 7. Always depressurize the adsorber to atmospheric pressure before disposing.
 8. Always bleed the helium charge down to atmospheric pressure before servicing or disassembling the self sealing couplings.
 9. Insure that there are no sources of ignition (e.g. hot filament vacuum gauges) on the cryopump side of the high vacuum valve operating during the warming or venting of the cryopump.
 10. Perform inert gas purge regeneration cycles at flow rates recommended for cryopumps.
 11. Regenerate as frequently as practical to minimize the amount of oxidizer present in the cryopump.
 12. It is standard practice in the vacuum industry that any system exposed to richer-than-air oxygen levels should be prepared for oxygen service per the manufacturer's recommendations, including use of oxygen service lubricating oils in roughing pumps.
 13. Crackling, popping sounds (as in electrical arcing) occurring within the first few minutes of a regeneration cycle.
 14. Gas venting from the cryopump during regeneration may have a pungent smell, similar to that present in an arc welding operation or after an electrical storm.
 15. All of the above oxygen precautions must be followed. The required regeneration frequency is dependent upon flow and process conditions. Daily regeneration may be required. Call Helix Technology Corporation for assistance.
 16. Reduce the oxygen mixture to the lowest level the process will allow.

Product Information and Technical Support

Please visit the Helix Technology Corporation Website located at <http://www.helixtechnology.com> to obtain additional product information or call the GUTS® (Guaranteed Uptime Support) Service Center for 24 hour, 7 day per week support by dialing:

800-367-4887 - Inside the United States of America

508-337-5599 - Outside the United States of America

On-Board IS Cryopump Installation

Follow the numbered steps in Figure 1 to install the On-Board IS Cryopump.

NOTE: Before mounting the On-Board IS Cryopump to the vacuum system, a high-vacuum isolation valve (Hi-Vac valve) should be installed between the On-Board IS Cryopump and the vacuum chamber to isolate the On-Board IS Cryopump from the chamber during rough pumping, cooldown, and regeneration.

NOTE: The On-Board IS Cryopump may be installed on the vacuum system Hi-Vac valve flange in any orientation without affecting its performance.

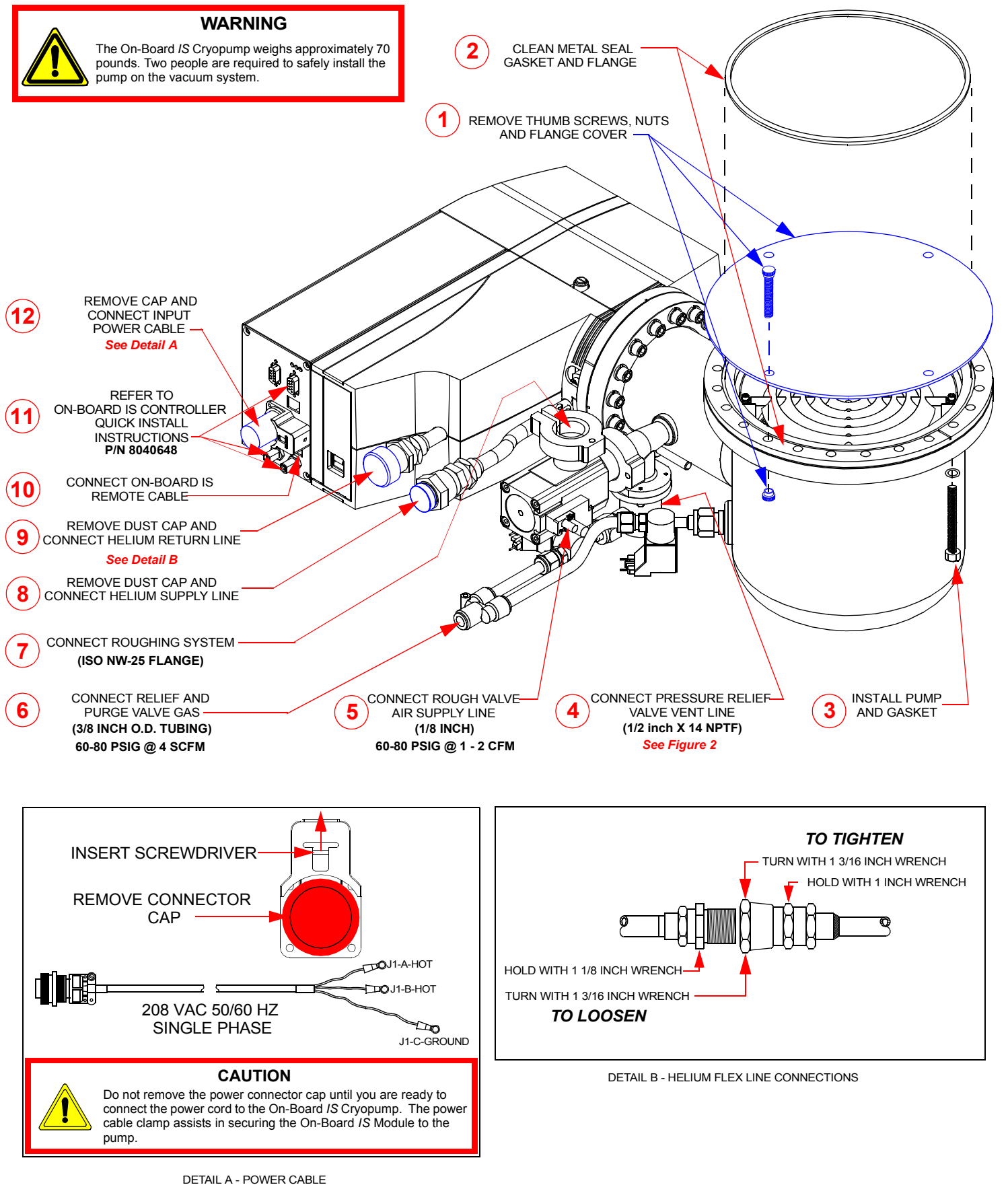

Figure 1: On-Board IS 8F Cryopump Installation Steps