

TELEDYNE HASTINGS

INSTRUCTION MANUAL INSTRUMENTS

DIGITAL VT

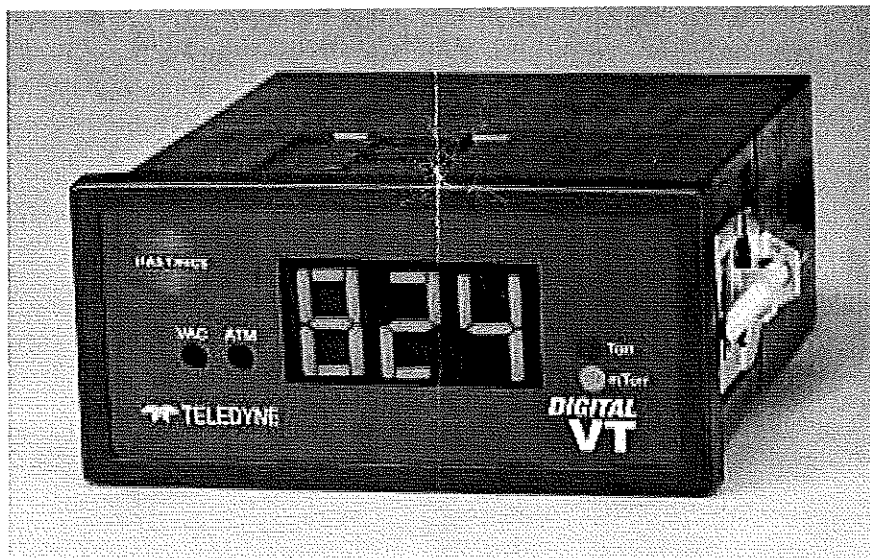

CE



TELEDYNE INSTRUMENTS
Hastings Instruments
A Teledyne Technologies Company



ISO 9001

KEMA CERT 10192.01



Accredited by the Dutch
Council for Accreditation (RvA)



Accredited by the Registrar
Accreditation Board (RAB)

Table of Contents

1.0 GENERAL INFORMATION	5
1.1 Features	5
1.2 Specifications	5
1.3 Safety	6
1.4 Accesories	6
1.4.1 Installation Accessories	6
1.4.2 DV-6S: New DV-6 Tube for Severe Environments	7
1.4.3 Calibration Reference Tubes	7
2.0 PANEL MOUNT INSTALLATION	9
2.1 Digital VT Outline Dimensions	9
2.2 Physical layout (Front)	10
2.3 Physical layout (Back)	10
2.4 Mounting Layout	11
3.0 VACUUM GAUGE OPERATION	13
3.1 AC Input Power	13
3.2 Quick Start	13
3.3 Pressure Measurement	13
3.4 Operation And Performance	13
3.5 Gauge Tube Operating Principle	14
3.6 Calibration	14
3.6.1 Preparation	15
3.6.2 Set High End	15
3.6.3 Set Low End w/Vacuum System	15
3.6.2 Set Low End w/Reference Tube	15
4.0 WARRANTY and REPAIR	17
4.1 Warranty Repair	17
4.2 Non-warranty Repair	17

General Information

This manual contains technical and general information relating to the installation, operation, and calibration of Hastings Vacuum Gauges, and Gauge Tubes.

For best performance, Hastings vacuum gauges should be operated with the appropriate Hastings gauge tube. Attempting to use a Hastings vacuum gauge with other manufacturers tubes may result in damage to both the gauge and tube.

1.1 Features

The Hastings Instrument's Digital VT, is a digital readout version of the successful VT-Series "Hastings Gauge" which has generated loyal customers for over 50 years. A reputation has been built on exceptional stability, accuracy, and reliability under the most demanding conditions.

A precision A/D converter, with a microprocessor is used to measure the gauge tube's signal output, it converts the measurement to a pressure reading using the gauge tube's well defined output/pressure function, and then display the result.

The Digital VT Vacuum Gauge Meter is available for two Hastings Instruments most popular gauge tube families: The DV-6 and DV-4. The DV-6 range is 0-1000 mTorr. The DV-4 range is 0-20 Torr. All VT-Series Vacuum Gauges feature long life and minimal maintenance.

These instruments utilize Hastings rugged noble metal TC gauge tubes that are designed specifically for each range.

Tubes are matched and interchangeable without calibration adjustments. They are compensated for temperature, rate of temperature change and are corrosion resistant.

1.2 Specifications

DIGITAL VT VACUUM METER:

INPUT POWER 4.5-5.3 volts DC, 155 ma
 W/ INCLUDED POWER CONVERTER 90-240 VAC, 47-63 HZ, 2 WATTS
 CABLES (Approx.) 6-ft. power cable and 8-ft. sensor cable included
 WEIGHT (Approx.) 1 lb

OPERATING TEMPERATURE RANGE 5°C to 50°C

STANDARD METAL GAUGE TUBE (DV-6R, DV-4R):

OVERPRESSURE 50 psig max.

MATERIAL OF CONSTRUCTION Nickel-Plated steel, Stainless Steel,
 Glass, Noble Metal, Thermocouples.

CONNECTIONS 1/8-in. NPT male thread

TUBE LEAK TEST 10⁻⁸ SCCS

GLASS Available for high temperature bakeable systems
 3/8 in. O. D. (10mm) smooth tubulation

vacuum sealant or Teflon® tape. For particularly dirty systems, Hastings offers a particle dropout trap containing a series of nine separate baffles which prevent solid contaminants from having a direct path to the sensor's thermopile.

1.4.2 DV-6S: New DV-6 tube For Severe Environments

Hastings Instruments has developed a new gauge tube (DV-6S) which is specifically designed for outdoor use on cryogenic tanks including railcar and tanker truck applications. In addition to the Digital VT, the gauge tube is compatible with the hand-held HPM-4/6 and the analog VT-6.

The DV-6S is supplied with a protective cap. The o-ring-sealed cap protects the gauge tube pins from moisture thus significantly reducing corrosion. A metal lanyard prevents cap loss. The tube is provided with a standard 1/8" NPT fitting, however special fitting requests can often be met.

1.4.3 Calibration Reference Tubes

Hastings Instruments Reference Tubes employ the same Hastings metal thermopiles used in all Hastings Vacuum Gauge Tubes. The thermopile is sealed in a glass capsule that has been evacuated, baked, outgassed, and then aged to ensure long-term stability. The sealed capsule is then housed in a protective metal shell to provide a rugged, trouble-free assembly.

Once assembled, the reference gauge tube is accurately calibrated to precisely simulate a gauge tube at a given operating pressure. It provides quick and easy instrument re-calibration by merely plugging the instrument and adjusting the zero potentiometer until the display reads the exact pressure noted on the reference tube.

SECTION 2

Installation

2.1 DIGITAL VT, OUTLINE DIMENSIONS

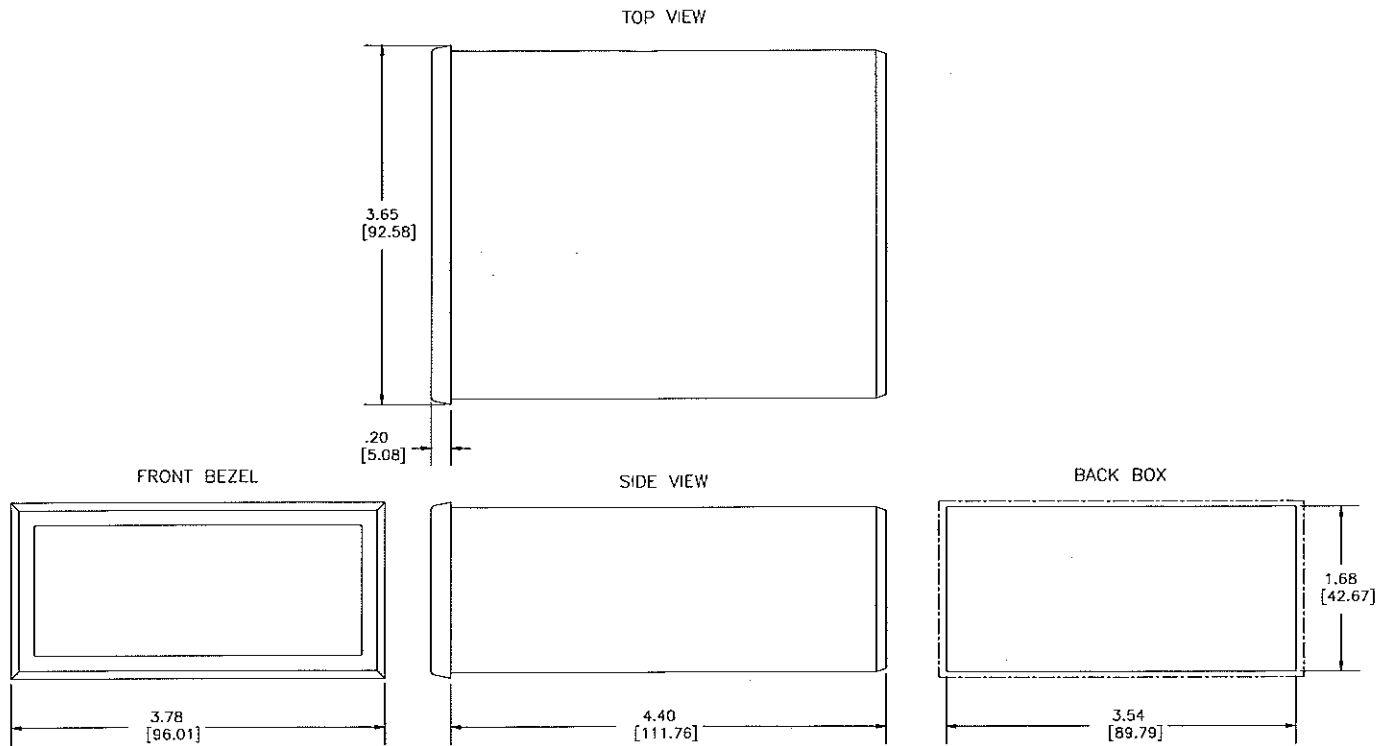
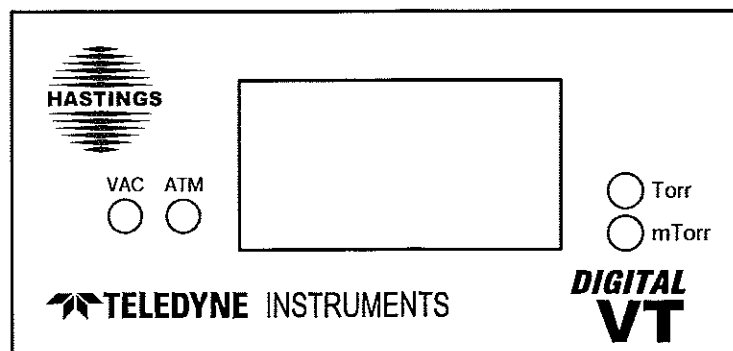

Fig. 1



DIGITAL VT, FRONT PANEL

Fig. 2

2.4 MOUNTING LAYOUT

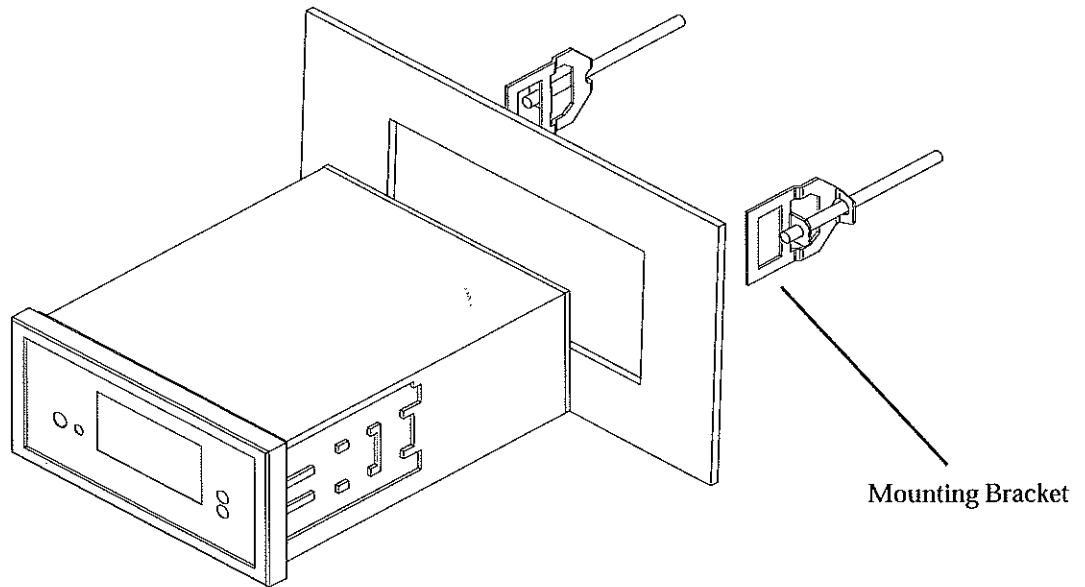



Fig. 5

VACUUM GAUGE OPERATION

All Hastings gauge tubes are shipped with a protective cap or cover at the evacuation port to reduce contamination and prevent damage to the internal thermopile elements. Once the protective cap or cover is removed, a tube can be installed in any convenient position in the vacuum system without adversely affecting calibration or performance. The recommended orientation is with the tube vertical and its stem down. This will aid in preventing condensable materials from remaining in the gauge tube.

3.1 AC Input Power

The Digital VT Power Supply input is rated as consuming 0.25 Amps @ 120VAC.

 The Power/Gauge Tube Cable, is assembled at the factory as shown in Fig. 4. It requires no further wiring to be performed. To operate the Digital VT, plug the Power/Gauge Tube Cable into the connector located in the rear of the Digital VT. Connect the plug of the power supply into a single phase 100-230 VAC, 50/60 Hz power source

3.2 Quick Start

1. Plug Digital VT power supply into a 100-230 Hz outlet source.
2. Connect a DV4 or DV6 gauge tube to the Octal Socket cable assembly that is attached to the rear of the Digital VT.
3. The CPU will do a self check/initialization. The digital display should count up and stop momentarily at FFE.
4. The Torr and mTorr LED's should also momentarily illuminate.
5. After the CPU is operating, and the self check/initialization is complete, the display will indicate the output of the DV4 or DV6 tube.
6. No other operator action is required.
7. For a more accurate reading from the DV4 or DV6 tubes, refer to Section 3.6 and perform a calibration of unit.

3.3 Pressure Measurement

Connect the gauge tube cable's octal socket onto the octal base of a gauge tube installed in vacuum system. The gauge will display the system pressure on the Digital VT. To check the accuracy of the gauge, perform the required operations as specified in section 3.3.

3.6.1 Preparation

1. Plug the Digital VT power supply into an outlet providing 100-230 VAC, 50/60 Hz.
2. CLEAR out any previously entered calibration data.
 - a. Using a pointed object, such as a ballpoint pen, press and hold the "ATM" push button located on the front panel until "CLR" appears on the digital display. The "ATM" button must be held in the pressed position approximately 5 seconds before data is cleared and "CLR" is displayed.

located on the front panel until "CLR" appears on the digital display. The "ATM" button must be held in the pressed position approximately 5 seconds before data is cleared and "CLR" is displayed.

Once "CLR" is displayed any previously entered data has been deleted.

3. Plug in DV-4 or DV-6 gage tube. Leave tube at atmospheric pressure.

NOTE: TUBE MUST BE AT ATMOSPHERE TO PROPERLY SET THE HIGH END.

3.6.2 Set High End

- A. Press "ATM" push button until "Set" appears. The high-end setting is now set.

NOTE: The LOW END can be adjusted by either bringing the system to a known vacuum or by using a HASTINGS REFERENCE TUBE.

3.6.3 Set Low End W/Vacuum System

- A. Set system to known vacuum.
- B. Turn the "VAC" pot on front panel until the known vacuum is displayed on digital display. (For DV-4 and/or DV-6 IF KNOWN VACUUM IS BELOW 1 mTorr SET DISPLAY TO ZERO).
- C. The low end is now adjusted.

3.6.4 Set Low End W/Reference Tube.

- A. Connect HASTINGS reference tube.
- B. Turn the "VAC" pot until the value printed on HASTINGS reference tube is displayed on digital Display.
- C. THE LOW END is now adjusted.

NOTE: If re-calibration is required you must first repeat step 2.

IF SEVERAL TUBES ARE TO BE READ AND RE-CALIBRATION FOR EACH TUBE IS NOT DESIRED, YOU MAY CLEAR THE CALIBRATION DATA (STEP 2) AND ONLY ADJUST THE LOW END SETTING ONCE. HOWEVER A LOSS OF ACCURACY WILL BE NOTICED ON THE HIGH END.

Note: The following table specifies the HASTINGS reference tube to be used in the calibration of a gage based upon the type of gauge tube being used.

Ref. Tube	Gauge Tube
DB-16D	DV-4
DB-18	DV-5
DB-20	DV-6

4.1 Warranty Repair Policy

Hastings Instruments warrants this product for a period of one year from the date of shipment to be free from defects in material and workmanship. This warranty does not apply to defects or failures resulting from unauthorized modification, misuse or mishandling of the product. This warranty does not apply to batteries or other expendable parts, nor to damage caused by leaking batteries or any similar occurrence. This warranty does not apply to any instrument which has had a tamper seal removed or broken.

This warranty is in lieu of all other warranties, expressed or implied, including any implied warranty as to fitness for a particular use. Hastings Instruments shall not be liable for any indirect or consequential damages.

Hastings Instruments, will, at its option, repair, replace or refund the selling price of the product if Hastings Instruments determines, in good faith, that it is defective in materials or workmanship during the warranty period. Defective instruments should be returned to Hastings Instruments, **shipment prepaid**, together with a written statement of the problem and a Return Material Authorization (RMA) number. Please consult the factory for your RMA number before returning any product for repair. Collect freight will not be accepted.

4.2 Non-Warranty Repair Policy

Any product returned for a non-warranty repair must be accompanied by a purchase order, RMA form and a written description of the problem with the instrument. If the repair cost is higher, you will be contacted for authorization before we proceed with any repairs. If you then choose not to have the product repaired, a minimum will be charged to cover the processing and inspection. Please consult the factory for your RMA number before returning any product repair.

TELEDYNE HASTINGS INSTRUMENTS
804 NEWCOMBE AVENUE
HAMPTON, VIRGINIA 23669 U.S.A.
ATTENTION: REPAIR DEPARTMENT
TELEPHONE (757) 723-6531
1-800-950-2468
FAX (757) 723-3925
E MAIL hastings_instruments@teledyne.com
INTERNET ADDRESS <http://www.teledyne-hi.com/>

Repair Forms may be obtained from the "Information Request" section of the Hastings Instruments web site.