

Cahn C-34,
C-35

Cahn C-34 Microbalance, Cahn C-35 Ultra-Microbalance

INSTRUCTION MANUAL

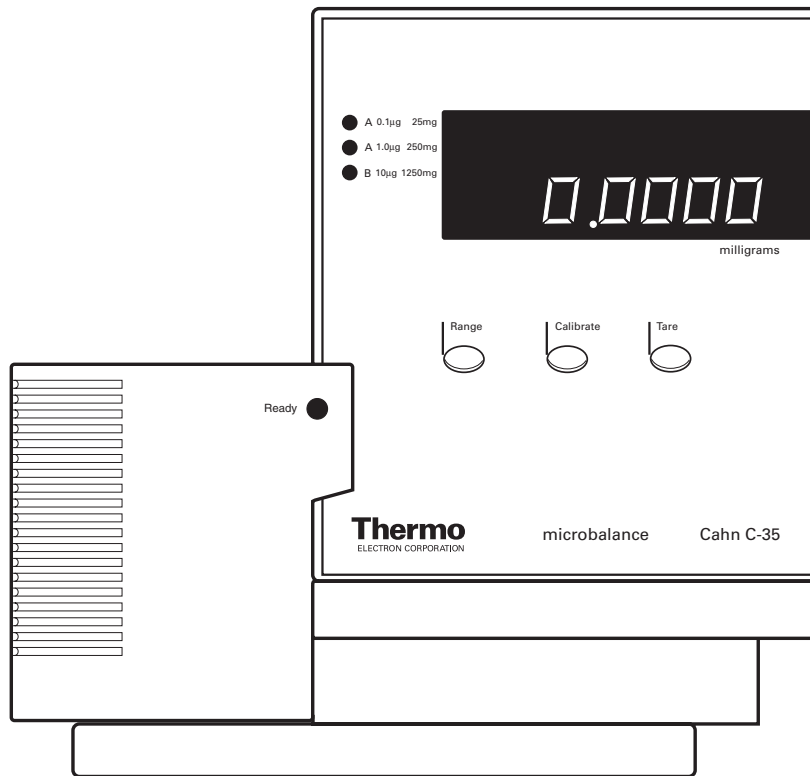

AQUAfast, Cahn, EZ Flash, Ionalyzer, ionplus, KNiPHE, No Cal, ORION, perpHect, PerpHecT, PerpHecTion, pHISA, pHix, pHuture, Pure Water, Sage, Sensing the Future, SensorLink, ROSS Ultra, Sure-Flow, TEA Analyzer, Titrator PLUS, TURBO2 and Wine Master are registered trademarks of Thermo Electron Corporation.

1-888-pHAX-ION, A+, All in One, Aplus, AQUAsnap, AssuredAccuracy, AUTO-BAR, AUTO-CAL, AUTO DISPENSER, Auto-ID, AUTO-LOG, AUTO-READ, AUTO-STIR, Auto-Test, BOD AutoEZ, Cable-Free, CERTI-CAL, CISA, DataCOLLECT, DataPLUS, digital LogR, DirectCal, DuraProbe, Environmental Product Authority, Extra Easy/Extra Value, FAST QC, Flash Titration, Flash Titrator, GAP, GLPcal, GLPcheck, GLPdoc, ISEasy, KAP, LabConnect, LogR, Low Maintenance Triode, Minimum Stir Requirement, MSR, NISS, One-Touch, One-Touch Calibration, One-Touch Measurement, Optimum Results, Pentrode, pHuture MMS, pHuture Pentrode, pHuture Quatrode, pHuture Triode, Quatrode, QuiKcheK, rlink, ROSS, ROSS Resolution, SAOB, Smart CheK, Stacked, Stat Face, The Enhanced Lab, ThermoSense, Triode, TRIUMPH, Unbreakable pH, Universal Access are trademarks of Thermo.

Guaranteed Success and The Technical Edge are service marks of Thermo.

PerpHecT meters are protected by U.S. patent 6,168,707.

PerpHecT ROSS are protected by U.S. patent 6,168,707.

ORION Series A meters and 900A printer are protected by U.S. patents 5,108,578, 5,198,093, and German patents D334,208 and D346,753.

Sure-Flow electrodes are protected by European Patent 278,979 and Canadian Patent 1,286,720.

ionplus electrodes and Optimum Results solutions are protected by US Patent 5,830,338.

ROSS Ultra electrodes have patents pending.

ORION ORP Standard is protected by US Patent 6,350,367.

ORION Series A conductivity meters are protected by US Patent 5,872,454.

© Copyright 2003, Thermo Electron Corporation. All rights reserved. Question everything, and Analyze. Detect. Measure. Control are trademarks of Thermo Electron Corporation.

The specifications, descriptions, drawings, ordering information and part numbers within this document are subject to change without notice.

This publication supersedes all previous publications on this subject.

Table of Contents

Section 1 Principles of Operation	1
Section 2 Installation	2
LOCATING THE BALANCE	2
SET UP	2
VOLTAGE SOURCE	3
FREEING HANGDOWN LOOPS	4
Section 3 Controls	5
RANGE	5
RANGE LIGHTS	5
TARE	5
CALIBRATE	6
WEIGHT DISPLAY	6
READY LIGHT	6
Section 4 Operation	7
MEASUREMENT HINTS	7
TURNING ON BALANCE	8
WARM UP TIME	8
SAMPLE POSITIONS	9
RANGE SELECTION	10
PAN SELECTION	10
ZEROING	10
CALIBRATION	11
CALIBRATION SCROLLING	11
ELECTRICAL TARING	12
COUNTERBALANCING	12
SUBSTITUTION WEIGHING	13
ELECTROSTATIC	13
RELOCATING THE BALANCE	13
AIR BAFFLES	13
Section 5 Maintenance and Troubleshooting	14
DAILY CARE	14
TROUBLESHOOTING	14
FACTORY REPAIRS	15
SERVICE AND REPAIR	16
Section 6 RS232 INTERFACE	17
RS232 CIRCUITS	17
WORD FORMAT	17
DIP SWITCH SETTINGS	18
OPERATING WITH A COMPUTER	19
INTERCONNECTING CABLES	20
PROGRAM DEVELOPMENT	20
Section 7 Appendix	22
GLOSSARY OF TERMS	22
WEIGHTS	23
MAINTAINING CALIBRATION STANDARD	23
Section 8 Warranty	25

Section 1 Principles of Operation

The Cahn C-34/C-35 is a very sensitive weight and force measurement instrument. It is designed for weights and forces up to 3.5 grams and is sensitive to changes as small as 0.1 micrograms. The balance may be described as a force-to-current converter. It consists of (1) a balance beam mounted to, supported by, and pivoting about the center of taut ribbon; (2) a torque motor coil located in a permanent magnetic field and also mounted to the taut ribbon; (3) sample suspension fixtures; (4) a beam position sensor system; and (5) controls, circuitry and indicators (See Figure 1).

Weights or forces to be measured are applied to the sample (left) side of the beam which produce a force about the axis of rotation. An electric current flowing in the torque motor also produces a force about the same axis which is equal and opposite to the force from the beam, if the beam is at the beam reference position. This reference position is detected by the beam position sensing system. A greater force on the beam will require a greater opposite force from the torque motor in order to keep the beam at its reference position. Therefore, the current necessary to produce the required torque motor force is a direct measure of the force on the beam. The process of calibration allows this current to be measured in units of weight (grams).

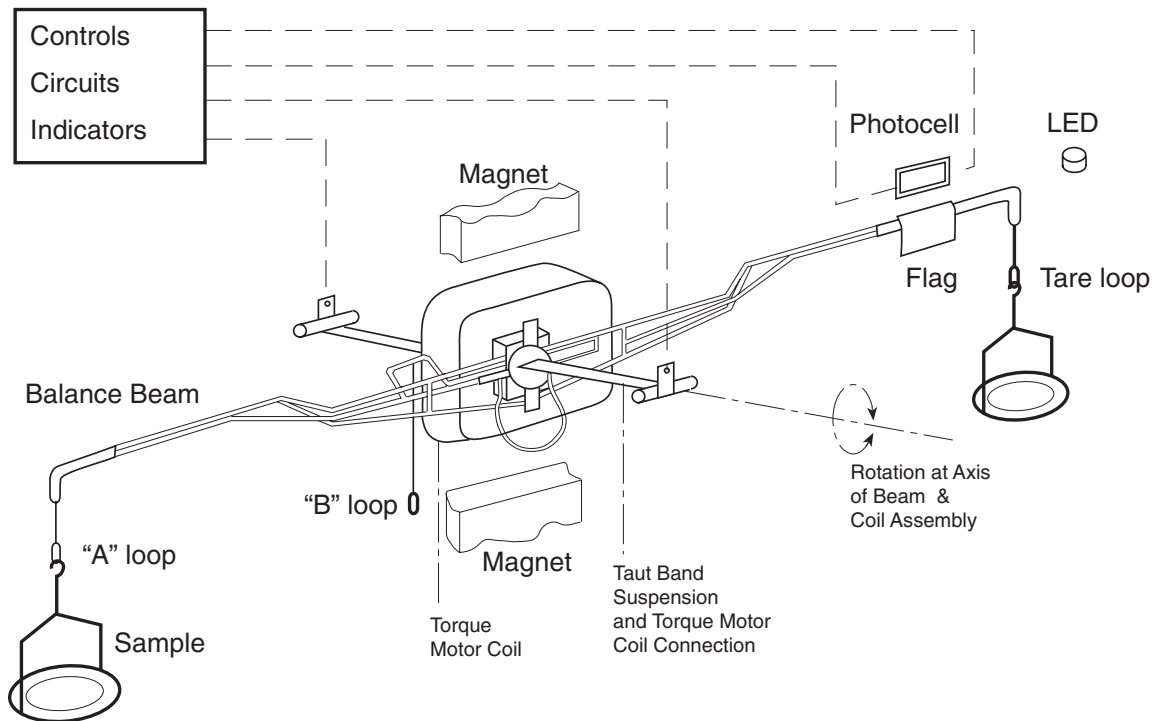

Figure 1: Principles of Operation

Section 2 Installation

LOCATING THE BALANCE

The Cahn C-34 or C-35 may be used in almost any location. It does not require leveling. However, the level should not change after zeroing. Try to avoid exceptionally shaky tables, direct sunlight or drafty locations (such as near air conditioners). For ultimate microweighing, avoid locations near equipment which generate vibrations such as vacuum pumps, air conditioners or heavy machinery. The Cahn C-34/C-35 is designed for operation between 15 and 30 degrees C and a relative humidity between 5% and 95% (non-condensing).

SET UP

Carefully unpack the Cahn C-34/C-35 from its box.

Prepare the weighing chamber by placing the spill plates in the chamber so they conform to the balance.

Attach the interface cable, Cahn 12634-01, between the weighing chamber and the electronics unit. First connect the cable to the Remote Port of the weighing chamber then the other end to the Remote Port on the electronics unit.

VOLTAGE SOURCE

The Power Cord is fitted with an U.S.-type plug. If the plug does not fit your electrical outlet, the plug may be cut off and your own plug installed. The color code for the Power Cord is:

- Black = line or hot
- White = return or neutral
- Green = ground or earth

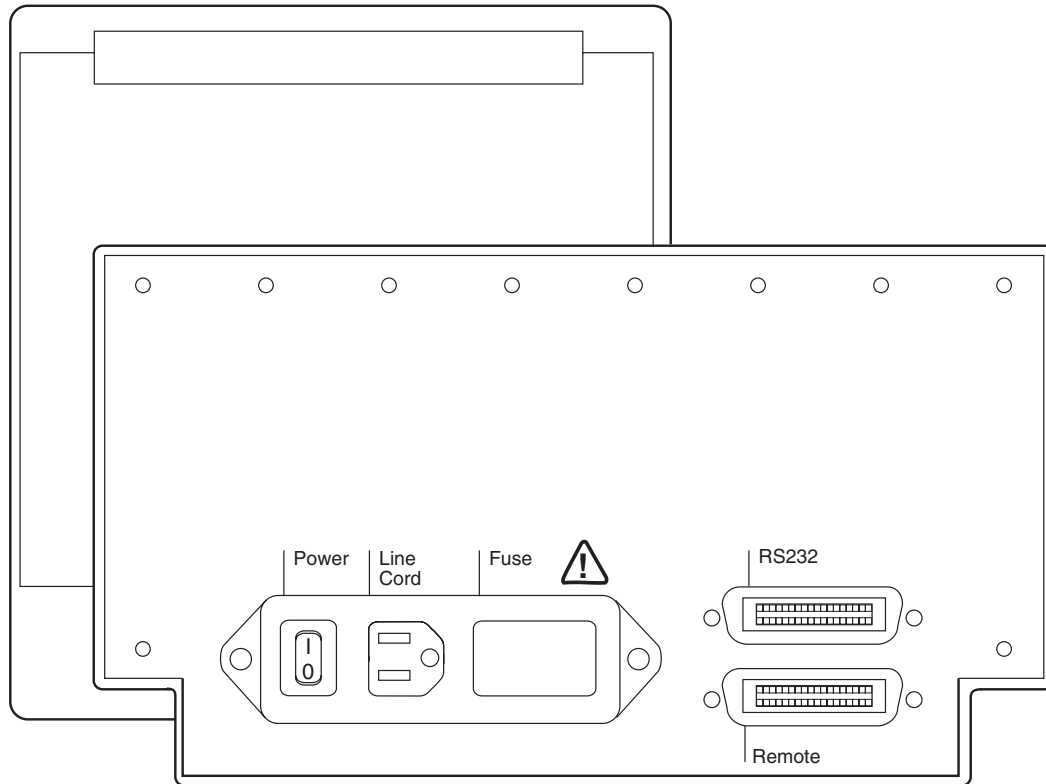

Figure 2: Voltage Source

FREEING HANGDOWN LOOPS

Free the Hangdown Loops inside the weighing chamber by cutting the strings first with sharp scissors and then removing the strings. Do not attempt to remove the tape without first cutting the strings (See Figure 3).

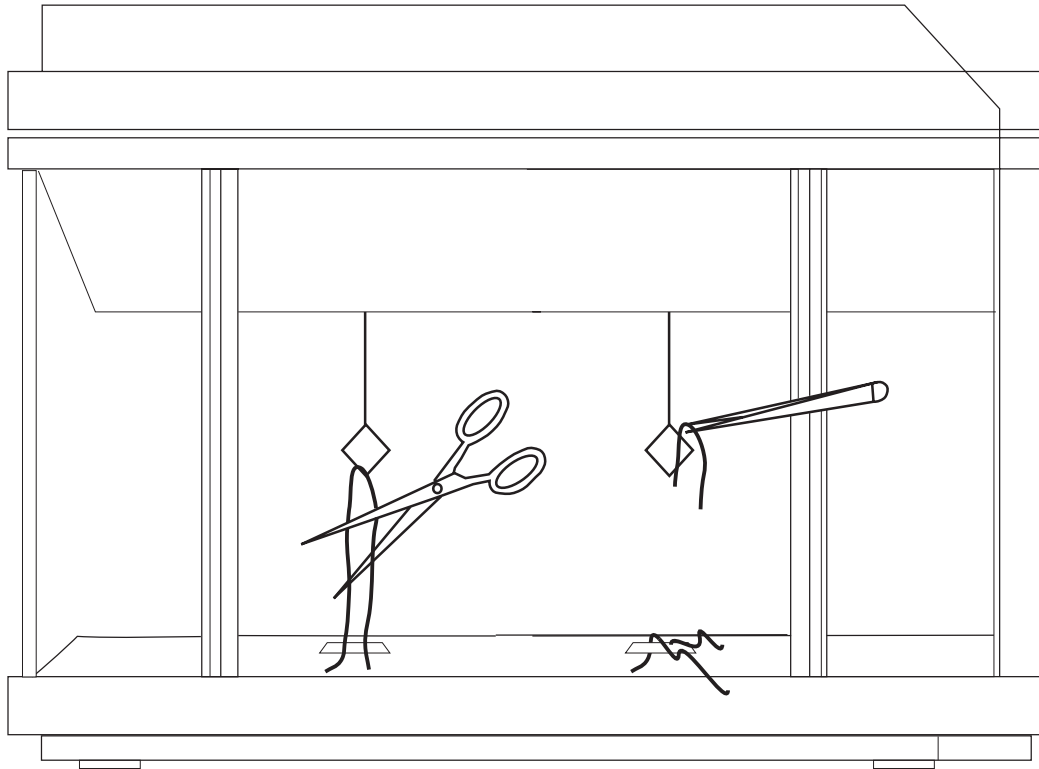

Figure 3: Freeing the Hangdowns

Section 3 Controls

The following brief description of the Cahn C-34 and C-35 controls will help you to understand the operation of the balance and will make weighing easier and faster. Figure 5 illustrates the front panel of the control unit.

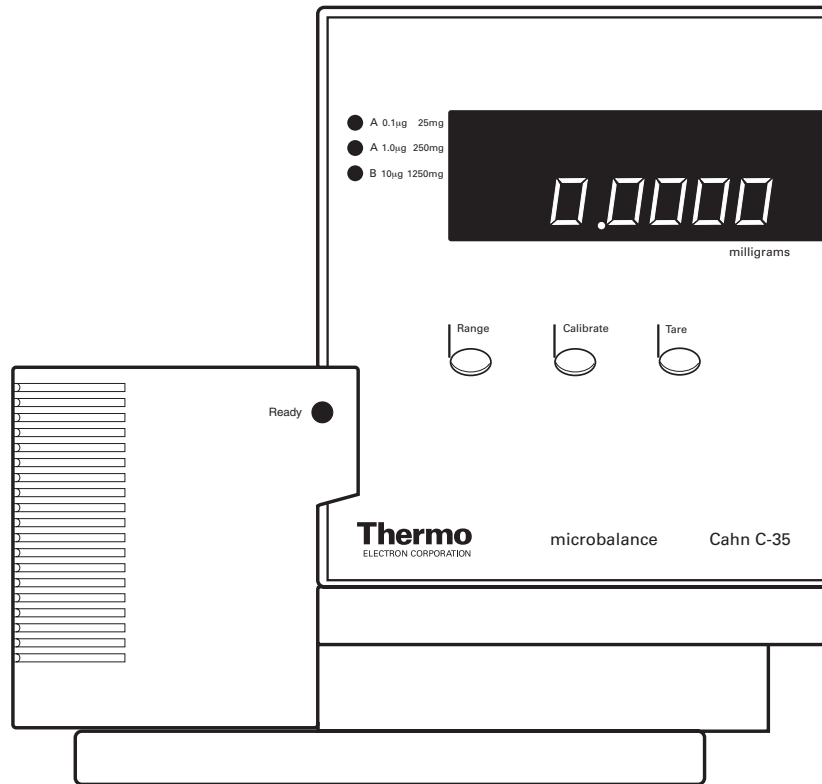

Figure 4: Front Panel

RANGE

This key allows you to select one of the weighing ranges of the balance. Each press of the key will advance the selection to the next range.

RANGE LIGHTS

Located on the upper left corner of the front panel, these red lights indicate which weighing range has been selected and the sensitivity of that range.

TARE

Pushing the key labeled TARE will bring the display to zero if the sample is within the selected Weighing Range of the balance.

CALIBRATE

This key will automatically calibrate the selected range when the appropriate calibrating weight is placed on the pan. The 200 mg weight is used to calibrate the A loop position and the 1000 mg weight is used to calibrate the B position. The Calibration control has a special “scrolling” feature that allows you to input the exact value of the calibration weight (see page 11).

WEIGHT DISPLAY

The value of the weight on the sample pan is shown in milligrams on the Weight Display. Since the balance will give either positive or negative weights within the selected weight range, the Weight Display shows a “plus” or “minus” sign. As you change ranges, the decimal point is automatically positioned. When the weight exceeds the weighting range, an “E” will be shown. If the calibrating weight is not in the calibration range of the balance, an “E3” will appear on the display.

READY LIGHT

Located to the left of the keypad is a single red light labeled “READY.” This light illuminates when a stable value is reached. The light will turn off when the balance senses an unstable value.

Section 4 Operation

This section will give details of the operation of the Cahn C-34/C-35 microbalance. It is advisable to read this section carefully at least once with the instrument, and then to make reference to it as necessary.

Various weighing procedures will be described in detail. You should be familiar with the controls as described in Section 3 before proceeding further with this section. It has been assumed that you have no previous experience with the Cahn C-34/C-35. As you become more familiar with the balance, the operating procedures will become routine.

MEASUREMENT HINTS

- Always use forceps to handle pans, stirrups and weights. To avoid contamination do not handle them with your fingers. Dip or swab the accessories in ammonia to clean them when necessary.
- Do not grasp the stirrups with the forceps. Lift them from below the yoke, as shown in the Figure 5 below. It is easy to exert excessive force on the hangdowns and beams if the stirrups are held too tightly.

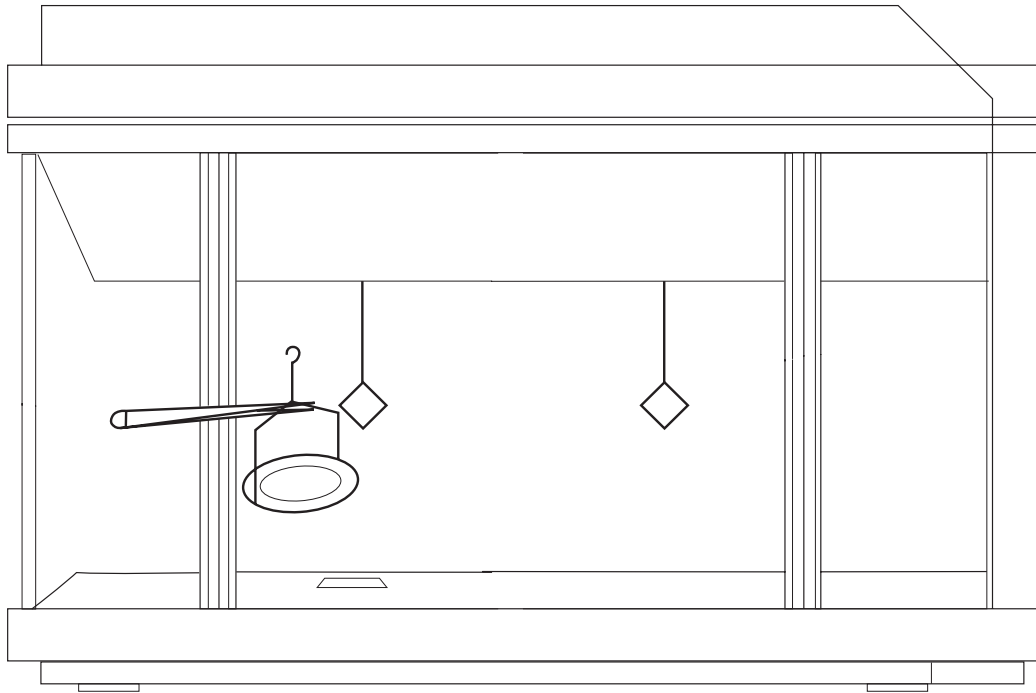

Figure 5: Handling the Stirrups

- Two types of weights are supplied with the Cahn C-34/C-35: calibration and tare weights. It is important to keep the two types separated. For more information about weights and the various classes, refer to the Weights section on page 23.
- The nonmagnetic, stainless steel forceps supplied with the balance have been found preferable to the common plastic tipped forceps. The Cahn type of forceps are specified by the NIST for the handling of small sheet metal weights. Plastic forceps are not recommended because they can hold a static charge which can be transferred to the weight or sample, producing erroneous readings. Also, do not use metal forceps with serrated tips which can scratch the weights.
- Care should be taken when working in the weighing chamber. The weighing hangdowns are fragile and if damaged, the balance must be returned to the factory for repair.
- The weighing chamber doors must be closed when zeroing, calibrating or weighing. When the balance is not in use, the chamber doors should be closed to reduce the possibility of contamination or damage.

TURNING ON BALANCE

Connect the balance to line power. Turn on the balance with the switch on the rear panel of the electronics unit. The Weight Display will show +8.8.8.8.8 indicating that the balance has been initialized. In this state, all previous calibration and calibration points have been lost. Also, all segments of the Display are lit allowing you to check that they are all functioning properly. After 5 to 10 seconds, press TARE to zero the display and set the balance into the operating mode.

WARM UP TIME

For precision weighing, adequate warm-up time is required. Normally, a minimum of one hour of warm-up time is necessary to avoid frequent rezeroing and recalibrating. A minimum of two hours of warm-up time should be allowed to achieve ultimate precision and stability. We recommend that the power stay on over night and weekends.

NOTE: A new unit should be allowed 24 hours of "burn in" time before any precise measurements are attempted.

SAMPLE POSITIONS

There are three fine metal loops attached to the balance beam (see Figure 6). Samples and counterweights are suspended from these by means of stirrups and pans. The sample suspensions are referred to as A, B and TARE loops. The A and TARE loops are equidistant from the pivot point of the beam. The A sample loop is at the end of the forward facing beam and has a maximum capacity of 1.5 grams. The TARE loop is at the opposite end of the beam and also has a maximum capacity of 1.5 grams. The B loop is 1/5th the distance from the pivot point as compared to the A loop. It is for sample loads up to 3.5 grams. This A and B loop information is needed for selecting the proper RANGE.

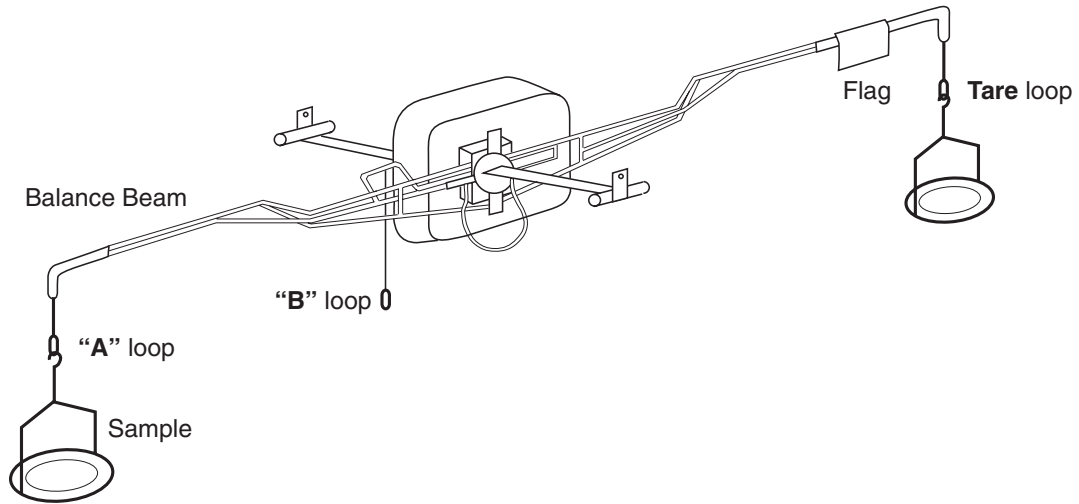

Figure 6: Balance Beam

RANGE SELECTION

In choosing a weighing range, you usually must consider two factors: required sensitivity and sample weight.

Weighing Ranges

	Cahn C-35	Cahn C-34
A Loop	0-250 mg 0-25 mg	0-200 mg
B Loop	0-1250 mg	0-1000 mg

There are two sensitivity ranges on the C34: .01 and .001 mg. The Cahn C-35 has an additional .0001 mg range. Choose the least sensitivity to produce the needed accuracy. Going beyond the required sensitivity will increase your weighing time and decrease your sample weight range. Once the sensitivity has been chosen, a corresponding weight range is determined. The weight range is the range of the weight values that can be read on the Weight Display. The Cahn C-34/C-35 has a very wide weight range for each available sensitivity and is usually sufficient for routine measurements. However, for those cases where the expected weight will exceed the selected weight ranges, see Substitution Weighing on page 13.

PAN SELECTION

Two sizes of stirrups are included in the Accessory Kit. The stirrup Cahn 09353-01 is for general weighing. Also included is open stirrup Cahn 02011-01 which is designed to hold the disposable pans Cahn 01187-01. A wide variety of other stirrups and sample containers are available.

ZEROING

Before putting the stirrups on the Hangdown Loops, select the desired Weighing Range and then press the TARE key. If using an "A" Weighing Range, place a selected stirrup on the "A" loop and a similar stirrup on the Tare loop. If the Weight Display reads a positive value, reverse the stirrups. You want the heavier stirrup on the Tare side. If using the "B" Weighing Range, place the heavier stirrup on the "B" loop and the lighter stirrup on the Tare loop. Check that the Range Indicator Lights match the selected sample stirrup position. Once the stirrups are stable, press TARE to bring the Weight Display to zero. If the value displayed is not zero, press the TARE key again.

CALIBRATION

A 200 mg Calibration Weight is supplied for the A range and a 1000 mg Calibration Weight is supplied for the B range.

Calibration Procedure:

1. Remove samples or containers from the stirrups. Press the TARE key to zero the balance.
2. If you are using the 25 mg range on the Cahn C-35, first zero the balance on the 25 mg range and then move to the 250 mg range for calibration. Both ranges are calibrated from the 250 mg position.
3. Place the Calibration Weight on the sample pan.
4. When the Weight Display has stabilized and the Ready Light illuminates, press the CALIBRATE key once. The value of the Calibration Weight will appear on the Display. [If "E3" appears in the Display, your Calibration Weight does not match your Weighing Range. Use proper Calibration Weight for desired Weighing Range or select proper Range.]
5. Remove the Calibration Weight from the sample pan and return it to its container. You may now tare and make sample weighings.

CALIBRATION SCROLLING

The calibration program has a scrolling function, with a range of 199.850 mg to 200.150 mg for the A loop and 999.25 mg to 1000.75 mg for the B loop. This feature allows you to use a calibration weight with an actual calibration value different from the preset value. The procedure below describes the use of scrolling.

1. Remove samples or containers from the stirrups. Press the TARE key to zero the balance.
2. Place Calibration Weight on the sample pan. Allow to stabilize.
3. Press the CALIBRATE key. The Weight Display will display 200.000 or 1000.00 .
4. Immediately press the CALIBRATE key again and keep it depressed. The digital display will start counting up from 200.000 or 1000.00. The longer you depress the CALIBRATE key the faster the count will increase. To avoid overshooting the value of your exact weight, release the key about 10 micrograms before the desired number is reached.
5. Press the CALIBRATE key repeatedly as you slowly approach the value of your exact Calibration Weight.
6. The display will increase to the maximum calibration range value for example, 1000.75 mg and then to the minimum calibration range value, 999.25 mg.
7. The balance will retain the new calibration value and will use the new value each time the CALIBRATE key is pressed.

NOTE: If power is interrupted, the calibration value will revert back to 200.000 or 1000.00 when CALIBRATE is pressed.

ELECTRICAL TARING

To tare the weight of a container electrically, press the TARE key which will cause the display to read zero. All ranges on both the Cahn C-34 and C-35 have full range taring. However, taring reduces the amount of weighting range available for sample weight. For example, if you tare a 50 mg container in the 200 mg range of the Cahn C-34, your sample must weigh less than 150 mg. For example:

$$200 \text{ mg} - 50 \text{ mg} = 150 \text{ mg}$$

(Full Range) - (Tare Weight) = Maximum remaining Sample Capacity

If your sample and container weigh more than the range selected, see the next section titled Counterbalancing.

The 25 mg range of the Cahn C-35 has an electronic “no penalty” tare. You can electronically tare up to 225 mg and still have full use of the 25 mg range. When using this range, an “E” indicating over-range will appear on the display when you place a weight between 25 and 250 mg on the sample pan. Just press the TARE key and the display will return to zero.

COUNTERBALANCING

Mechanical taring is used when a container weights are larger than the electronic weighing range or when the whole weighing range is needed for the sample weight. The purpose of counterbalancing is to achieve a mechanical state of balance of the beam before starting to weigh the sample. The procedure for counterbalancing is as follows:

1. Select the desired range.
2. Place container on the sample pan.
3. Add tare weights to the tare pan until the loads on both pans are approximately equal (the Weight Display is almost zero).

NOTE: The easiest way to counterbalance a container on the A loop is to place a similar container on the tare loop.

4. Press the TARE key to zero the balance.
5. Place your sample in the sample container. The Weight Display will show only the weight of the sample.

The position of the B loop is one-fifth the distance from the balance pivot point than the A loop. Therefore, tare weights of one-fifth the amount of the weight being tared should be used.

SUBSTITUTION WEIGHING

The balance can only lift 200 mg (250 mg for the Cahn C-35) when the sample is on the A loop and 1000 mg (1250 mg for the Cahn C-35) when the sample is on the B loop. When you are required to know the exact weight of a sample that is heavier than these values, substitution weighing is used. The procedure is as follows:

1. Select the proper loop, stirrups and sample container.
2. Zero and calibrate the C-34/C-35 as described on page 10.
3. Select the substitution weights. A wide variety of Class 1.1 calibration weights suitable for substitution weighing are available from Cahn. Choose a combination slightly less than the expected weight of the sample and place them on the sample pan. (Note that the maximum weight of the sample plus container should not be greater than 1.5 grams for the A loop and 3.5 grams for the B loop.)
4. Place tare weights on the tare pan until you have brought the Weight Display close to zero. Press the TARE key to bring the Weight Display to zero.
5. Remove the substitution weight from the sample pan. Do not remove any of the tare weights. Place the sample onto the sample pan. The weight of the sample is the sum of the Weight Display and the substitution weights.

ELECTROSTATIC

An electrostatic charge ("static") will prevent a microbalance from being used to its full potential. Common symptoms of this problem include noisy readout, drift and sudden readout shifts. The most common source of static is dry weather and the handling or touching of nonconductive surfaces. There are steps you can take to avoid and eliminate static problems. Technical Note "Static Control for Balances" contains more detailed information about static and how to minimize its effects and is available upon request.

Placing a radioactive ionizing unit, Cahn 01269-01 in the weighing chamber works well to remove static charge from the balance surfaces and samples.

Coating the inside of the weighing chamber window with antistatic solution Cahn 02027-01 also helps to eliminate and prevent static.

Always use the type of metal nonmagnetic forceps which are supplied with the balance.

RELOCATING THE BALANCE

The Cahn C-34/C-35 may be moved from one location to another. For short relocation (within a building), simply turn off and unplug the balance, disconnect the Weighing Chamber from the Electronics Unit and carry the balance to the new location. You do not have to remove the stirrups from the hangdown loops. If you are going to transport the balance in a car, remove the stirrups first. You do not have to secure the hangdown loops with threads unless there is a chance that the balance will be turned upside down. If the balance is inverted, the hangdown loops may slip into the balance motor chamber if the loops are not first secured.

AIR BAFFLES

Air Baffles Cahn 10940-01 are an optional accessory designed to reduce the time to make a weighing by reducing the air turbulence in the Weighing Chamber). They are most useful when using the 25 mg weighing range on the Cahn C-35, but can be used for weighing on any "A" Loop range on either the Cahn C-34 or C-35. The Air Baffles are cylinders installed at the bottom of the Weighing Chamber such that they protect the pans from the air currents that may be present in the chamber.

Section 5 Maintenance and Troubleshooting

DAILY CARE

No special daily maintenance is required for the C-34/C-35 balance. It is recommended that the balance remain in the power ON condition unless the balance will not be used for several weeks or longer.

Immediately clean all spilled material. Wipe it up only with lintless paper cloth.

IMPORTANT: Whenever it becomes necessary to work in the weighing compartment to remove accidentally dropped samples, etc., you should first remove the stirrups and sample pans from the hangdowns. This will avoid inadvertent damage to the stirrup or hangdowns.

TROUBLESHOOTING

If the instrument apparently fails to yield reliable data, try and locate the source of the problem using the following troubleshooting chart. The troubleshooting chart includes common problems which may arise.

SYMPTOMS	CAUSES	REMEDY
Balance does not function after being plugged in and turned on.	-Weighing Chamber interface cable not connected to Electronics Unit -Instrument Failure	Connect the Weighing Chamber interface cable to the lower RS232 port. In North America call 800-225-1480 for Service. Outside North America call your local Cahn dealer. All digits segments are lit
(+8.8.8.8.8). -Normal instrument operation	when first turned on. -Power interruption or brownout Press the TARE key to clear	Rezero and Recalibrate "E" appears when weighing
-Sample weight exceeds range	capacity Reduce sample weight,	counterbalance or change range "E3" appears when weighing
-CALIBRATE pressed -Calibration weight does not match	range Rezero Use proper calibration weight	Switch position three (3) Line

FACTORY REPAIRS

Should it become necessary to return the instrument to the factory for repairs, follow the instructions below for repacking.

Remove all items including power cord, stirrups, pans, loose weights, etc. Do not return these items to us. We need only the balance to effect repairs.

NOTE: Please see service and repair if balance needs to be returned to the factory for repair.

To avoid damaging the hangdowns, they should be secured before shipment. **THE HANGDOWNS ARE DELICATE, SO USE THE UTMOST CARE** (see Figure 7). Thread and small strips of masking tape are recommended. Cut approximately 7" of nylon thread per hangdown. Loop the thread through each diamond shaped hangdown loop and loosely secure both ends of thread to the bottom of the weighing chamber (with the chamber pans removed) with masking tape.

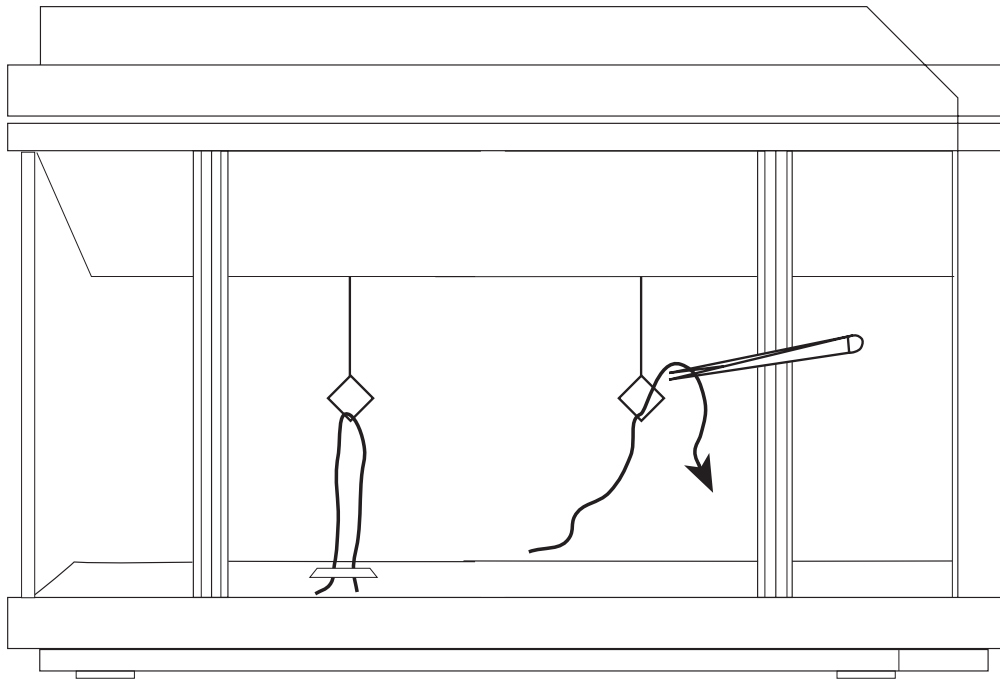

Figure 7: Securing the Hangdowns

Remove the glass doors from the weighing chamber. Repack the balance in its original container or, if it is not available, wrap the balance in several inches of bubble pack before placing it in a packing carton filled with resilient packing material. A small amount of time spent on proper packing can save considerable expense on repairs due to shipping damage.

For shipment by motor freight, express, etc., pack this carton inside a second one, with resilient material between the cartons. A single carton is adequate for air freight.

SERVICE AND REPAIR

Technical Support for Cahn microbalances can be obtained by contact The Technical EdgeSM for Cahn products. Within the United States call 1.800.225.1480, outside the United States call 978.232.6000 or fax 978.232.6031. In Europe, the Middle East and Africa, contact your local authorized dealer. Before returning any balance to the factory please obtain a return authorization from Thermo Electron Corporation.

To speed up assistance it is recommended that you call from a phone which is close to the balance (and computer if applicable) in case we ask you to try a couple of tests on the equipment. If the problem is computer related, we will need to know the program version number (found at the beginning of the Table of Contents), the DOS version in your computer (at the DOS prompt, enter VER) and the contents of your system files. To get this system information, enter the following commands at the DOS prompt:

```
CD \ (press ENTER)
TYPE AUTOEXEC.BAT (press ENTER)
TYPE CONFIG.SYS (press ENTER)
```

If the files are long, you can print the information by turning on the printer and entering the following command at the DOS prompt:

```
CD \ (press ENTER)
TYPE AUTOEXEC.BAT>PRN (press ENTER)
TYPE CONFIG.SYS>PRN (press ENTER)
```

Section 6 RS232 INTERFACE

The Cahn C-34/C-35 has an EIA standard RS232C compatible I/O port which may be used to connect the balance to a personnel computer or other computing device with a similar interface port.

RS232 CIRCUITS

The balance will be connected in such a way that it appears to be a data terminal (DTE). The following RS232C circuits are utilized by the balance interface:

Pin 2: Transmitted Data: will carry data transmitted by the balance (TXD).

Pin 3: Received Data: will carry data to the balance (RXD).

Pin 7: Signal Ground: this circuit will be connected to the ground of the balance (common return). (GND)

WORD FORMAT

The balance will transmit and receive data in the following format:

The word length will be seven (7) or eight (8) data bits programmed via the dip switch.

For details of this switch, see Dip Switch Settings. There will be no parity transmitted or detected.

There will be one (1) or two (2) stop bits programmed via a dip switch.

The signaling rate (baud rate) will be programmed via a combination of three dip switches. There will be eight possible baud rates. These are 150, 300, 600, 1200, 1800, 2400, 3600 and 4800.

DIP SWITCH SETTINGS

A six (6) position dip switch (see Figure 8) has been installed on the processor card of the Cahn C-34/35 to control configuration of the serial I/O port. This switch allows the user to select the baud rate, word length, number of stop bits and operating mode of the balance. The red dip switch is in the lower right corner of the card. DO NOT REMOVE CARD to change dip switch positions. Change the dip switch setting only when the power to the balance is OFF. After setting the switches, replace the cover immediately to prevent damage to the instrument.

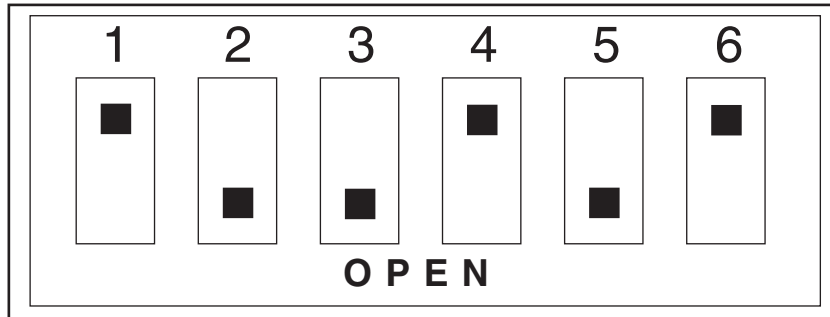

Figure 8: DIP Switches

The position is "open" when the lower portion of the switch is pressed into the block.

Baud Rate: The baud rate is set by the combination of the setting of the switch positions four, five and six in the following manner:

NOTE: A zero (0) means the switch is closed, a one (1) means the switch is open.

Baud rate	Switch #		
	4	5	6
150	0	0	0
300	0	0	1
600	0	1	0
1200	0	1	1
1800	1	0	0
2400	1	0	1
3600	1	1	0
4800	1	1	1

Switch position one (1) controls the operating mode. This switch should remain closed to operate in the open loop mode. In this mode, there will be no reply sent to the remote computer to indicate that the command has been executed except for the enquire command which will transmit the balance reading. The computer should allow the balance enough time to execute the command before sending another command in about one second.

Switch position two (2) controls the number of stop bits. When position two is open, two (2) stop bits are used. When position two is closed, one (1) stop bit is used.

controls the word length. When position three is open, eight (8) data bits are transmitted and received. When position three is closed, seven (7) data bits are transmitted and received. The balance is shipped from the factory with the switches set as follows:

open loop mode
2 stop bits,
8 data bits
600 baud rate

OPERATING WITH A COMPUTER

The balance will respond to a number of commands received via the serial report via the computer. The following set of commands are those recognized by the Cahn C-34/35:

Command	Code	ASCII	Hex	Action
Enquire	ENQ		05	Sends the current balance reading to the computer.
	or E		45	
Calibrate	C		43	Computes a new calibration constant.
Tare	T		54	Sets the tare weight register to the current gross weight and displays a reading of zero.
Set Range	"a"		61	Set range to 0 25 mg, loop A
	"A"		41	Set range to 0 250 mg, loop A
	"B"		42	Set range to 0 1250 mg, loop B

ENQUIRE COMMAND DATA FORMAT

When transmitting the balance reading to a remote computer, the following format will be used:

0 25 mg range
(+/-)XX.XXXX,c (carriage return)
0 200 mg or 0 250 mg range
(+/-)XXX.XXX,c (carriage return)
0 1000 mg or 0 1250 mg range
(+/-)XXXX.XX,c (carriage return)

There will be either a plus sign or a minus sign followed by the numeric value of the reading in milligrams followed by a comma followed by a single character which indicates the status of the balance followed by an ASCII carriage return (hex OD). The numeric reading will have either two, three or four digits to the right of the decimal point depending on the range setting.

The status character (indicated in the example by the small letter c) indicates the condition of the reading and will have one of the following values:

S The reading is stable.
U The reading is unstable.
O The reading is overrange.

NOTE: An overrange reading will return a numeric value of 9999.99 no matter what range is set.

INTERCONNECTING CABLES

Care must be taken when selecting a cable to connect the balance into a computer. A straight through cable (pin 1 to pin 1, etc.) will not function properly. A Null Modem, or crossover cable (pin 2 to pin 3, pin 3 to pin 2) is required to interface a Cahn C-34/C-35 with a computer. This cable is available from any computer store. If you have an IBMAT type computer, you will need a cable with a DB9 connector on the computer end and a DB25 connector on the balance end. This is a crossover cable and should work with the balance.

PROGRAM DEVELOPMENT

Almost any computer equipped with a RS232C serial port can be used with a Cahn C-34/C-35 balance that is also equipped with RS232. Today's computers are easy to program for accessing the balance. The RS232 port uses commands similar to those used for accessing the disk drive. The port is assigned to a buffer, an OPEN statement is used to open the port, a PRINT statement is used to send a command, and a LINE INPUT statement is used to assign the data to a variable.

The following program was written for an IBM PC computer. Programs for other computers are similar to this program.

```
10 REM C35 Data Acquisition
20 OPEN COM1:600,N,8,2,CS,DS,CD AS #1
30 CLS: PRINT SELECT RANGE:
40 PRINT A=25 MG RANGE '
50 PRINT B =200/250 MG RANGE
60 PRINT C= 1000/1250 MG RANGE
70 Z$=INKEY$: IF Z$ = GOTO 70
80 IF Z$= A THEN PRINT #1, a: GOTO 110
90 IF Z$= B THEN PRINT #1, A: GOTO 110
100 IF Z$= C THEN PRINT #1, B ELSE GOTO 70
110 CLS
120 PRINT PRESS W FOR WEIGHT, A FOR AVERAGE
130 Z$=INKEY$: IF Z$= GOTO 130
140 IF Z$= A GOTO 250
150 IF Z$ < > W GOTO120
160 PRINT #1, E
170 LINE INPUT #1, A$
180 IF RIGHT$(A$,1)= U THEN PRINT READING UNSTABLE: GOTO 120
190 IF RIGHT$(A$,1)= O THEN PRINT OVER RANGE: GOTO 120
200 L=LEN(A$)
210 W$=LEFT$(A$,L 2)
220 W=VAL(W$)
230 N=N+1: PRINT DATA; N; =; W; mg
240 T=T+W: GOTO 120
250 CLOSE: A=T/N: PRINT: PRINT AVERAGE =; A
260 END
```

20 opens communication port #1, sets the baud rate to 600, selects no parity, 8 bit word length and 2 stop bits (see Dip Switch Settings, page 20). The port is then assigned to buffer #1. The PRINT command in line 80, 90 or 100 sends the range set command to the balance. The PRINT command in line 150 sends an enquire command to the balance asking for a weight reading. If the balance cannot respond to this command, the program will lock. If this should occur, enter BREAK. If another attempt to read the weight fails, there is a problem with your interface.

Line 160 enters the weight reading into variable A\$.

Lines 170 and 180 look at the status character to assure that the weight reading is stable.

Lines 190 and 200 strip off the comma and status character from the weight reading.

Line 210 transforms the weight reading from a string variable to a numeric variable in order to do numerical computation.

Line 250 contains a CLOSE command to close the buffer and port before finding the average weight.

The above program and notes are not intended to be a complete course on how to program your computer for RS232. However, if you have a passing understanding of BASIC programming, writing your own program to access the RS232 feature should not be difficult.

Section 7 Appendix

GLOSSARY OF TERMS

ACCURACY is defined as the agreement of a balance reading with the value as set by a national standard.

CAPACITY of the sample suspension is defined as the maximum total load (sample, container, wire, etc.) that can be suspended from the sample loop. As the load increases beyond the rated capacity, the following will occur in the order shown:

The beam will slightly bend which will reduce repeatability.

The motor coil will sag into its stops, causing it to become inoperable but preventing damage.

The hangdown loop will break preventing serious damage to the beam.

REPEATABILITY (or Precision) is defined by Cahn as the standard deviation of 10 consecutive weighings of the same mass under ideal conditions.

READABILITY is the least significant digit which can be resolved from the readout under normal conditions and set up.

SENSITIVITY is the smallest mass difference that can be detected by the balance.

PERFORMANCE SPECIFICATION FOR Cahn C-34/C-35		
	LOOP A	LOOP B
Capacity	1.5 grams	3.5 grams
Weight range/sensitivity	25 mg/0.1 250 mg/1.0	1250 mg/ 10
Tare: Mechanical	1.5 grams	3.5 grams
Electrical	250 mg	1250 mg
Accuracy (percent of weight range limited by precision)	.0012%	.008%
Precision Ultimate	0.1g	1
Fraction of load	.0001%	.001

WEIGHTS

A Class 1.1 (formerly Class M) 200 and 1000 mg Calibrating Weights are supplied with the Cahn C-34/C-35 balance. They are the most accurate weights available with a tolerance of 0.005 mg. For substitution weighing, as described on page 15, you should order additional weights that you feel may be needed. A wide variety of Class 1.1 weights are available from Cahn as well as a weight box to protect them. Always return these weights to their containers after use. Do not touch them with your fingers or contaminated forceps. Class 1.1 weights can be identified by their mirror finish.

Most counterweighing can be done with the tare weights supplied in the Tare Weight Set. These weights are Class 6 with a tolerance from 0.1 to 1 mg. Tare weights can be identified by the dull finish.

MAINTAINING CALIBRATION STANDARD

For the most effective calibration control over a long period of time, we recommend the use of two calibration weights. The first weight is used as a primary weight and is kept locked in a secure place.

Once every six months, or at any time when the working calibration weight is in doubt, the primary weight is used to calibrate the balance. Then the working calibration weight is measured. For routine calibration of the balance, the working calibration weight is used by setting its measured value into the balance (see Calibration Scrolling on page 13). With careful handling of the primary weight, consistent calibration can be maintained over a period of many years.

Section 8 Warranty

For the most current warranty information, visit www.thermo.com.

The Thermo Electron Corporation, Orion products warranty covers failures due to manufacturer's workmanship or material defects from the date of purchase by the user. User should return the warranty card and retain proof of purchase. Warranty is void if product has been abused, mis-used, or repairs attempted by unauthorized persons.

Warranties herein are for product sold/installed by Thermo or its authorized dealers.

Any product sold by a U.S. or Canadian distributor must be returned to Thermo for any warranty work. Please contact our Technical Service department for further information. A Return Authorization Number must be obtained from The Technical EDGESM for Orion Products before returning any product for in-warranty repair or replacement.

In the event of failure within the warranty period, Thermo will at the company's option, repair or replace product not conforming to this warranty. There may be additional charges, including freight, for warranty service performed in some countries. For service, call Thermo or its authorized dealer outside the United States and Canada. Thermo reserves the right to ask for proof of purchase, such as the original invoice or packing slip.

Field Service is available on Orion BOD AutoEZTM, EZ Flash[®] GC Accessory and TEA Analyzer[®]. Contact our Field Service department for details on quotations and service, other field service-related activities.

The following products are warranted to be free from defects in material and workmanship in the period listed below from the date of purchase from the user or from the date of shipment from Thermo, whichever is earlier, provided use is in accordance with the operating limitations and maintenance procedures in the instruction manual and when not having been subjected to accident, alteration, misuse, abuse or breakage of electrodes:

Thirty-six months from date of purchase by the user (or forty-two months from date of shipment from Thermo)

- Waterproof Meters (Orion 630, 635, 830A, 835A, 260A, 261S, 265A, 266S, 130A, 131S, 135A and 136S), Conductivity Meters (Orion 105Aplus, 115Aplus, 125Aplus, 145Aplus, 150Aplus and 162A), PerpHect[®] pH/ISE Meters (Orion 310, 320, 330, 350, 370) pH/ISE Meters (Orion 210Aplus, 230Aplus, 250Aplus, 290Aplus, 410Aplus, 420Aplus, 520Aplus, 525Aplus, 710Aplus, 720Aplus and 920Aplus), pHuture MMSTM Meters (Orion 535A and 555A), pH/Conductivity Meter (Orion 550A), Dissolved Oxygen Meters (Orion 805Aplus, 810Aplus, 850Aplus and 862A).

Twenty-four months from date of purchase by the user (or thirty-six months from date of shipment from Thermo)

- Orion ROSS Ultra[®] Electrodes, Orion AQUAfast[®] IV Colorimeters, Orion AQUAfast[®] IV Turbidimeter, Orion 925 Flash TitratorTM, Series 100 DuraProbeTM Conductivity Cells and Series 800 Dissolved Oxygen Probes.

Twelve months from date of purchase by the user (or eighteen months from date of shipment from Thermo)

- Laboratory pH Meters, (Orion 301, 611 and 940), SensorLink[®], pHuture™ pH Meters (Orion 610 and 620), Sage[®] Pumps, Cahn[®] Balances, 930 Ionalyzer[®], 950 ROSS™ FAST QC™ Titrator, 960 Titrator PLUS[®], Karl Fischer Titrators, Autosamplers, Liquid Handling Devices, Liquid Handling Automation Workstations (Orion AS2000, AS2500 and AS4000), Pumps (Orion SP201, SP201-HR, SP201-S, Peristaltic and Rinse), pHuture[®] Conversion Box, Wine Master[®], 607 Switchbox, rlink™, AQUAfast[®] II Colorimeters, Vacuum Degasser and Flowmeter.
- Orion EZ Flash[®] GC Accessory, Orion TEA Analyzer[®] 610 and 510 excluding consumable items carry twelve months warranty only.
- Orion Ion Selective Electrodes, ionplus[®] Electrodes, ROSS™ Electrodes, Sure-Flow[®] Electrodes, PerpHecT[®] Electrodes, AquaPro Professional Electrodes, No Cal™ pH electrodes, Standard Line pH Electrodes, Tris pH Electrodes, KNiPHE[®] electrode, ORP Triode™ (Orion 9180BN), pHuture™ pH Probes (Orion 616500) and pHuture MMS™ Quatrode™ and Triode™ (Orion 616600 and 617900), Orion 97-08 DO Probe, Series 100 Conventional Conductivity Cells, temperature probes and compensators (except those products noted).
- Orion 93 and 97 ionplus Series sensing modules are warranted to give six months of operation if placed in service before the date indicated on the package, except 93-07 and 97-07 Nitrate modules are warranted to give ninety days of operation if placed in service before the date indicated on the package.

Six months from date of purchase by the user (or twelve months from date of shipment from Thermo)

- Orion Flash Titration™ Probe (Orion 092518), pHuture™ Electrode (Orion 615700), pHuture MMS™ Pentrode™ (Orion 617500), Quatrode™ (Orion 617800) and Triode™ (Orion 615800), Low Maintenance Triode™ (Orion 9107BN), ORP Low Maintenance Triode™ (Orion 9179BN), and PerpHecT[®] Low Maintenance Triode™ (Orion 9207BN), Waterproof Triode™ (Orion 9107WP, 9107WL, 9109WL and 9109WP), QuiKcheK[®] Meters and Micro Electrodes.

Three months from date of purchase by the user (or six months from date of shipment from Thermo)

- Economy Line Electrodes, Orion 91-05, 91-06, 91-15, 91-16, 91-25, 91-26, 91-35, 91-36, 92-06. Warranty also includes failure for any reason (excluding breakage), except abuse, provided the electrode is not used in solutions containing silver, sulfide, perchlorate, or hydrofluoric acid; or in solutions more than one (1) Molar in strong acid or base at temperatures above 50 °C.

“Out-of-Box” Warranty - Should any of the following products fail to work when first used, contact Thermo immediately for replacement.

- Orion Solutions, Standards, Reagents, Cables, Ferrules, Tubing, Line adapters, Printers, Software, Cases, Stands, Probe Membranes, AQUAfast[®] Test Strips, EZ Flash[®] columns, Liquid Handling Probes, Adapter Plates and Racks and general accessories.

For products in the catalog not listed in this warranty statement, please visit our website at:
www.thermo.com

THE WARRANTIES DESCRIBED ABOVE ARE EXCLUSIVE AND IN LIEU OF ALL OTHER WARRANTIES WHETHER STATUTORY, EXPRESS OR IMPLIED INCLUDING, BUT NOT LIMITED TO, ANY IMPLIED WARRANTY OF MERCHANTABILITY OR FITNESS FOR A PARTICULAR PURPOSE AND ALL WARRANTIES ARISING FROM THE COURSE OF DEALING OR USAGE OF TRADE. THE BUYER'S SOLE AND EXCLUSIVE REMEDY IS FOR REPAIR OR REPLACEMENT OF THE NON-CONFORMING PRODUCT OR PART THEREOF, OR REFUND OF THE PURCHASE PRICE, BUT IN NO EVENT SHALL THERMO (ITS CONTRACTORS AND SUPPLIERS OF ANY TIER) BE LIABLE TO THE BUYER OR ANY PERSON FOR ANY SPECIAL, INDIRECT, INCIDENTAL, OR CONSEQUENTIAL DAMAGES WHETHER THE CLAIMS ARE BASED IN CONTRACT, IN TORT (INCLUDING NEGLIGENCE), OR OTHERWISE WITH RESPECT TO OR ARISING OUT OF THE PRODUCT FURNISHED HEREUNDER. REPRESENTATION AND WARRANTIES MADE BY ANY PERSON, INCLUDING ITS AUTHORIZED DEALERS, REPRESENTATIVES AND EMPLOYEES OF THERMO WHICH ALTER OR ARE IN ADDITION TO THE TERMS OF THIS WARRANTY SHALL NOT BE BINDING UPON THERMO UNLESS IN WRITING AND SIGNED BY ONE OF ITS OFFICERS.

Environmental Instruments

Water Analysis

North America

166 Cummings Center
Beverly, MA 01915 USA
Tel: 978-232-6000
Dom. Fax: 978-232-6015
Int'l. Fax: 978-232-6031

Europe

12-16 Sedgeway Business Park
Witchford, Cambridgeshire
England, CB6 2HY
Tel: 44-1353-666111
Fax: 44-1353-666001

Far East

Room 904, Federal Building
369 Lockhart Road
Wanchai, Hong Kong
Tel: 852-2836-0981
Fax: 852-2834-5160

Customer Support

Toll Free: 800-225-1480
www.thermo.com
Dom. e-mail: domcs1@thermoorion.com
Int'l. e-mail: intcs1@thermoorion.com

For updated contact information, visit www.thermo.com

Analyze • Detect • Measure • Control™

227373-001 Rev.D

Thermo
ELECTRON CORPORATION