

66000-M  
10/12/90

# **ORIEL** CORPORATION

250 Long Beach Boulevard  
Stratford, CT 06497-0872  
Phone: (203) 377-8282  
Fax: (203) 378-2457

## **UNIVERSAL ARC LAMP HOUSING MODELS 66000 THROUGH 66005 66010 THROUGH 66013 66028 AND 66046**

Please read these instructions completely before  
operating this equipment.

If there are any questions or problems regarding  
the use of this equipment, please contact:

**ORIEL CORPORATION**

- or -

**ORIEL S.A.R.L.**  
9 Avenue De Laponie  
Z.A. De Courtaboeuf  
91951 Les Ulis Cedex  
France  
Phone: 01-69-07-20-20  
Fax: 01-69-07-23-57

**ORIEL SCIENTIFIC, LTD.**  
1 Mole Business Park  
P.O. Box 31  
Leatherhead  
Surrey KT22 7AU  
England  
Phone: 0372-378822  
Fax: 0372-375-353

- or -

The representative from whom this equipment was purchased.

---

## TABLE OF CONTENTS

|     |   |    |
|-----|---|----|
| I   | INTRODUCTION .....  | 3  |
| II  | SAFETY CONSIDERATIONS.....  | 5  |
|     | II.1 RADIATION.....   | 5  |
|     | II.2 LAMP EXPLOSION.....  | 5  |
|     | II.3 OZONE .....  | 6  |
|     | II.4 ELECTRICAL SHOCK .....   | 6  |
|     | II.5 EMI .....  | 7  |
|     | II.6 HEAT .....   | 7  |
| III | GENERAL DESCRIPTION .....   | 8  |
|     | III.1 LAMP AND REFLECTOR ADJUSTMENTS .....                              | 8  |
|     | III.2 BUILT-IN IGNITOR.....   | 8  |
|     | III.3 LAMP COOLING.....   | 8  |
|     | III.4 SAFETY AND MONITORING FEATURES.....                               | 9  |
|     | III.5 ELAPSED TIME INDICATOR .....                                      | 9  |
|     | III.6 HOUSINGS WITHOUT CONDENSING LENSES.....                           | 9  |
|     | III.7 MOUNTING.....   | 9  |
| IV  | LAMP INSTALLATION AND INITIAL OPERATION .....                           | 13 |
|     | IV.1 ADJUSTMENT OF LAMP, MIRROR AND LENS.....                           | 17 |
|     | IV.2 COOLING.....   | 20 |
| V   | LAMP HOUSING OPTICS.....  | 23 |
|     | V.1 COLLIMATED BEAMS.....   | 24 |
|     | V.2 UNIFORMITY.....   | 25 |
|     | V.3 IMAGING THE ARC.....  | 26 |
|     | V.4 REAL LENS.....  | 27 |
|     | V.5 HOW DO YOU POSITION THE CONDENSER TO<br>GET A COLLIMATED BEAM?..... | 30 |
| VI  | CIRCUIT DESCRIPTION.....  | 31 |
|     | VI.1 IGNITION CIRCUIT .....   | 31 |
|     | VI.2 COOLING FAN CONTROL CIRCUIT .....                                  | 31 |
|     | VI.3 ELAPSED TIME INDICATOR DRIVE CIRCUIT .....                         | 32 |
|     | VI.4 INTERLOCK CIRCUIT .....  | 32 |
| VII | TROUBLESHOOTING.....  | 33 |
|     | VII.1 INTRODUCTION .....  | 33 |
|     | VII.2 PROBLEMS .....  | 33 |
|     | WARRANTY  |    |
|     | RETURNS   |    |
|     | DRAWINGS  |    |
|     | SCHEMATICS  |    |
|     | PARTS LISTS   |    |

# I

---

## INTRODUCTION

---

This manual covers the Oriel 50 to 500 watt (W) Universal Lamp Housings with internal ignitors. We divide them into two categories: housings for 50 to 250 W short arc lamps, and housings for 200 to 500 W lamps.

### 50 to 250 W Lamp Housings:

- 66000 Lamp Housing with no condenser
- 66001 Lamp Housing with F/1.5 condenser
- 66002 Lamp Housing with F/1 condenser
- 66003 Lamp Housing with F/0.85 condenser
- 66004 Lamp Housing with F/0.7 glass/fused silica condenser
- 66005 Lamp Housing with F/0.7 fused silica condenser

### 200 to 500 W Lamp Housings:

- 66010 Lamp Housing with no condenser
- 66028 Lamp Housing with F/1.5 condenser
- 66011 Lamp Housing with F/1 condenser
- 66046 Lamp Housing with F/0.85 condenser
- 66012 Lamp Housing with F/0.7 glass/fused silica condenser
- 66013 Lamp Housing with F/0.7 fused silica condenser

The housings have the same basic design and differ in the condensing lens assembly and fan. With the appropriate socket adapter you can interchange between Hg, Xe, and Hg(Xe) lamps of different power. An ignitor is built into the top of the lamp housing. This reduces RF interference, and eliminates the need for a stand alone ignitor.

These lamp housings are designed to operate with Oriel Power Supplies. Table 1 on the following page shows the appropriate socket adapter for each lamp, and the power supply you should use.

**Table 1 Appropriate Socket Adapters and Power Supplies for Oriel Lamp Housings**

| Lamp Housing | Lamp            |                 | Socket Adapter | Power Supply       |                    |
|--------------|-----------------|-----------------|----------------|--------------------|--------------------|
|              | Type            | Model No.       |                | Type               | Model No.          |
| 50 to 250 W  | 75 W Xe         | 6251            | 66150          | 50-200 W Universal | 68805              |
|              | 75 W Xe OF      | 6263            | 66150          | 50-200 W Universal | 68805              |
|              | 150 W Xe        | 6253            | 66151          | 50-200 W Universal | 68805              |
|              | 150 W Xe UV     | 6254            | 66151          | 50-200 W Universal | 68805              |
|              | 150 W Xe OF     | 6255            | 66151          | 50-200 W Universal | 68805              |
|              | 150 W Xe        | 6256            | 66152          | 50-200 W Universal | 68805              |
|              | 50 W Hg         | 6282            | 66158          | 50-200 W Universal | 68805              |
|              | 100 W Hg        | 6281            | 66150          | 50-200 W Universal | 68805              |
|              | 200 W Hg        | 6283            | 66153          | 50-200 W Universal | 68805              |
|              | 200 W Hg(Xe)    | 6291            | 66152          | 50-200 W Universal | 68805              |
|              | 200 W Hg(Xe) OF | 6292            | 66152          | 50-200 W Universal | 68805              |
| 200 to 500 W | 200 W Hg        | 6283            | 66144          | 50-200 W Universal | 68805              |
|              |                 |                 |                | 200-500 W Hg       | 68810              |
|              | 350 W Hg        | 6286            | 66161          | 200-500 W Hg       | 68810              |
|              | 500 W Hg        | 6285            | 66162          | 200-500 W Hg       | 68810              |
|              | 300 W Xe        | 6259            | 66160          | 200-500 W Xe       | 68811              |
|              | 300 W Xe OF     | 6258            | 66160          | 200-500 W Xe       | 68811              |
|              | 400 W Xe        | 6260            | Not Required   | 200-500 W Xe       | 68811              |
|              | 200 W Hg(Xe)    | 6291            | 66157          | 50-200 W Universal | 68805              |
|              |                 |                 |                | 200-500 W Xe       | 68811              |
|              |                 | 200 W Hg(Xe) OF | 6292           | 66157              | 50-200 W Universal |
|              |                 |                 |                | 200-500 W Xe       | 68811              |
|              | 500 W Hg(Xe)    | 66142           | 66159          | 200-500 W Xe       | 68811              |

## II

---

### **SAFETY CONSIDERATIONS**

---

#### Summary of Hazards

There are six hazards in the operation of systems employing these lamp housings. They are:

- Radiation
- Lamp Explosion
- Ozone
- Electrical Shock
- EMI
- Heat

The interlock system is designed for your safety. Do not defeat the interlocks.

#### **II.1 RADIATION**

The high intensity UV radiation of these lamps can permanently damage the cornea, lens, and retina of the eye, even causing blindness. This damage may not be immediately apparent. The deep UV is absorbed in the cornea or eye fluids; focused UV, VIS and NIR can damage the retina. Normal blink reaction to visible light may not be adequate protection, and a beam of invisible UV or NIR (produced by spectral filtering) can be most dangerous as the blink response is not induced. UV radiation can also cause painful sunburn, and with prolonged exposure, serious burns.

#### Recommendations:

- 1 Never look directly into the output beam of a housing when operating a lamp.
- 2 Never look at a specular (mirror) reflection of the beam, even for short periods of time.
- 3 Use the interlock system to prevent access to a working lamp.
- 4 Always wear UV safety eyewear or facemask, and protective clothing for exposed areas of skin.

#### **II.2 LAMP EXPLOSION**

When cold, xenon and mercury(xenon) arc lamps are under several atmospheres of pressure and are subject to explosion due to internal strains or to physical abuse. When hot, all lamps are under a pressure of close to 100 atmospheres and subject to violent explosion.

Recommendations:

- 1 Do not handle a bare arc lamp without safety goggles and adequate protection for exposed areas of skin.
- 2 Do not apply torque to the lamp envelope during installation or removal.
- 3 Do not touch the lamp envelope. Fingerprints and other contaminations left on the lamp cause a deterioration of the envelope during operation and may lead to lamp explosion.
- 4 Thoroughly clean the envelope with alcohol or a dilute solution of detergent and water after installation in the housing.
- 5 Cover the aperture of the housings without condensers, before operation.

### II.3 OZONE

Shortwave ultraviolet light photolyzes oxygen to produce ozone. This is emitted in the cooling air stream of the lamp housing. There is no simple way of predicting the ozone concentration (or its impact on you) e.g., operation in a small enclosed area may lead to high concentrations. Operation of the same system in a large, well ventilated laboratory may not be a problem. Recommended maximum exposures are typically:

- 0.1 ppm for 8 hours exposure
- 2 ppm for a 2 hour exposure

A very sensitive nose can detect 0.015 ppm. 1 ppm produces a strong and obnoxious odor. As a rule of thumb, if you can easily smell ozone, the level is too high for prolonged exposure.

Recommendations:

- 1 Use an ozone free lamp unless you need the shortwave UV.
- 2 Operate the system in a large ventilated area.
- 3 Use an Ozone Eater™, found in our Volume II catalog.

### II.4 ELECTRICAL SHOCK

A high (>20kV) transitory voltage is used to ignite the lamp. Lamp current is up to 22 amperes. Additionally, line voltage is supplied to the housing to power the fan and elapsed timer. This line voltage will still be present even when the power supply is disconnected from the housing.

---

Recommendations:

- 1 Keep personnel clear of all exposed terminals.
- 2 Before relamping or working on the system, disconnect the input power to the lamp housing from the line, turn off the power supply and check the power supply voltmeter for zero voltage to be sure that internal capacitors are fully discharged.
- 3 Make sure all connections are securely made (and check the polarity) before starting a lamp.
- 4 Do not handle the lamp leads during lamp ignition.

## II.5 EMI

Ignition of an arc lamp requires high voltage high frequency (100's of kHz) pulses. A high current dump (kHz discharge) follows. Both of these are sources of electromagnetic interference, both radiated and conducted. Good earthing and cable routing practice, and EMI shielding may be necessary to protect sensitive digital circuitry from these pulses.

Recommendations:

- 1 Start the arc lamp before powering nearby computer systems.
- 2 Keep the computer at least 6 feet away from the ignitor/power supply.
- 3 Use a different outlet and line for the computer and ignitor/power supply.

## II.6 HEAT

Arc lamps become very hot after only minutes of operation, and remain very hot for up to 10 minutes after being shut off.

Recommendations:

- 1 Do not touch the lamp with your bare hands for at least 10 minutes after being shut off.

## III

---

### GENERAL DESCRIPTION

---

These lamp housings are lightweight but rugged. They are excellent choices for most low to medium power laboratory lamps. You can mount them to optical tables, rails, or benches. Various models with different condensers are available. With the complete line of optical accessories described in Volume II, you can filter, focus, and steer the output to fit your application.

Both types of lamp housings described in this manual (50 to 250 W and 200 to 500 W), use the same shell. The 200 to 500 W models have a more powerful fan to ensure correct operating conditions for the higher wattage lamps, and a different mounting block to accept the larger lamps.

#### III.1 LAMP AND REFLECTOR ADJUSTMENTS

The position of the arc (relative to the terminals which secure the lamp) varies slightly from lamp to lamp. This is because of normal arc lamp manufacturing tolerances. These lamp housings have adjustments to place the arc of a new lamp in the same position as that of the lamp being replaced. Three fine controls position the reflector. Then, independent tilt controls position the arc horizontally and vertically. The reflector and its controls travel with the vertical and horizontal controls. This eliminates the need for iterative lamp-reflector adjustments. See Fig. 1 on page 10 for location of adjusters.

#### III.2 BUILT-IN IGNITOR

The housings described in this manual have an ignitor built into the top of the housing. Short arc lamps require a high voltage spike, up to 40 kV for Xe lamps, to ignite. Having the ignitor built into the lamp housing minimizes unwanted radiated or conducted RFI.

#### III.3 LAMP COOLING

The built in fan and housing baffles maintain the proper operating temperature for arc lamps, when operated in normal laboratory ambient. Overheating due to blocking of the cooling vents or an inoperative fan, activates a thermostat interlock.

The cooling fan can be operated on 110 or 220 volts AC line. The housings have an AC connector which is designed to accept U.S. style power cords. The housings are supplied with a power cord. If the power cord is not compatible with your wall socket, replace the plug at the end of the power cord. Check that the line select switch (below the fan) is in the appropriate 110/220 V position before plugging the line cord into the nearest available AC outlet.



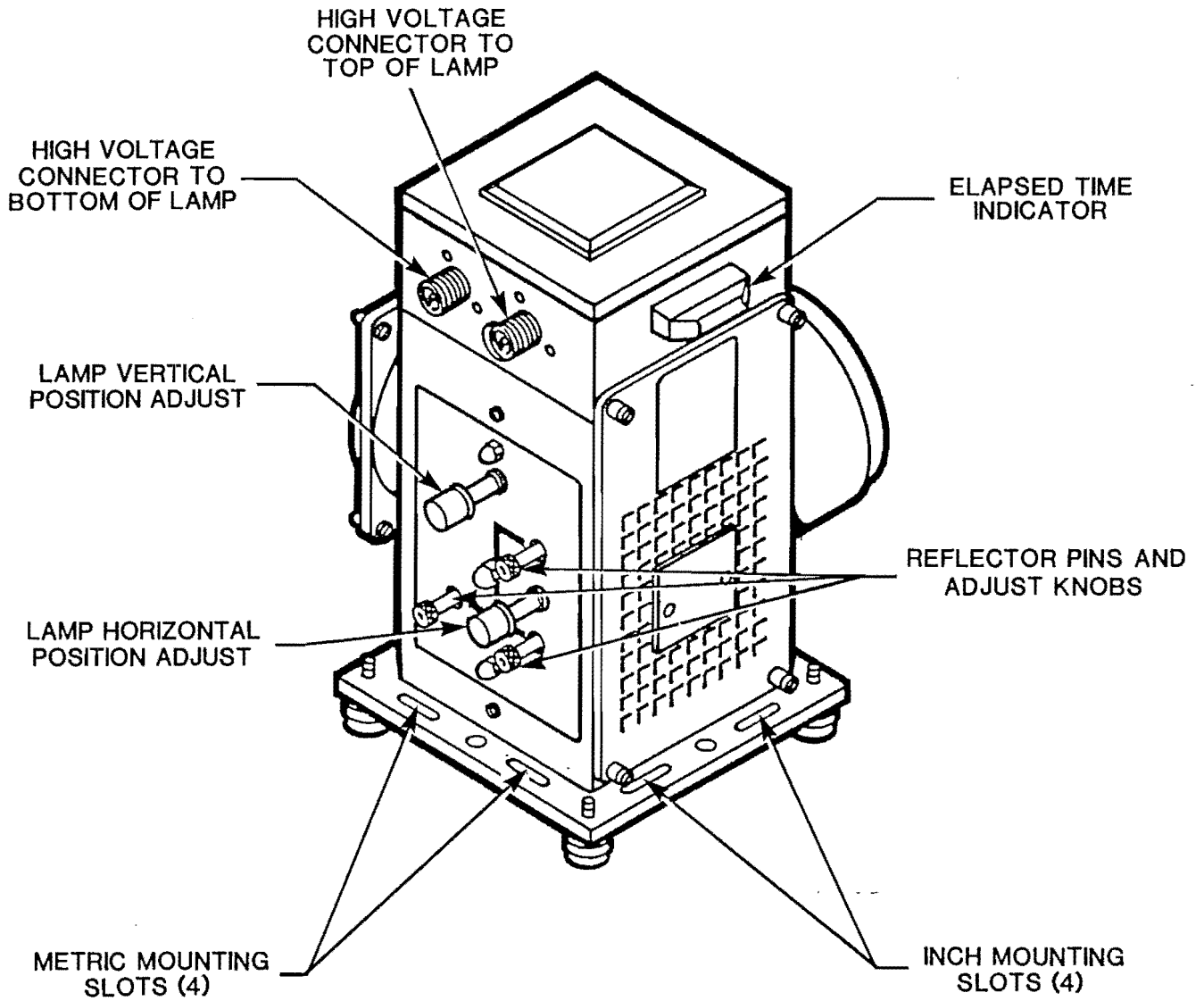

Fig. 1 Lamp and reflector adjustments.

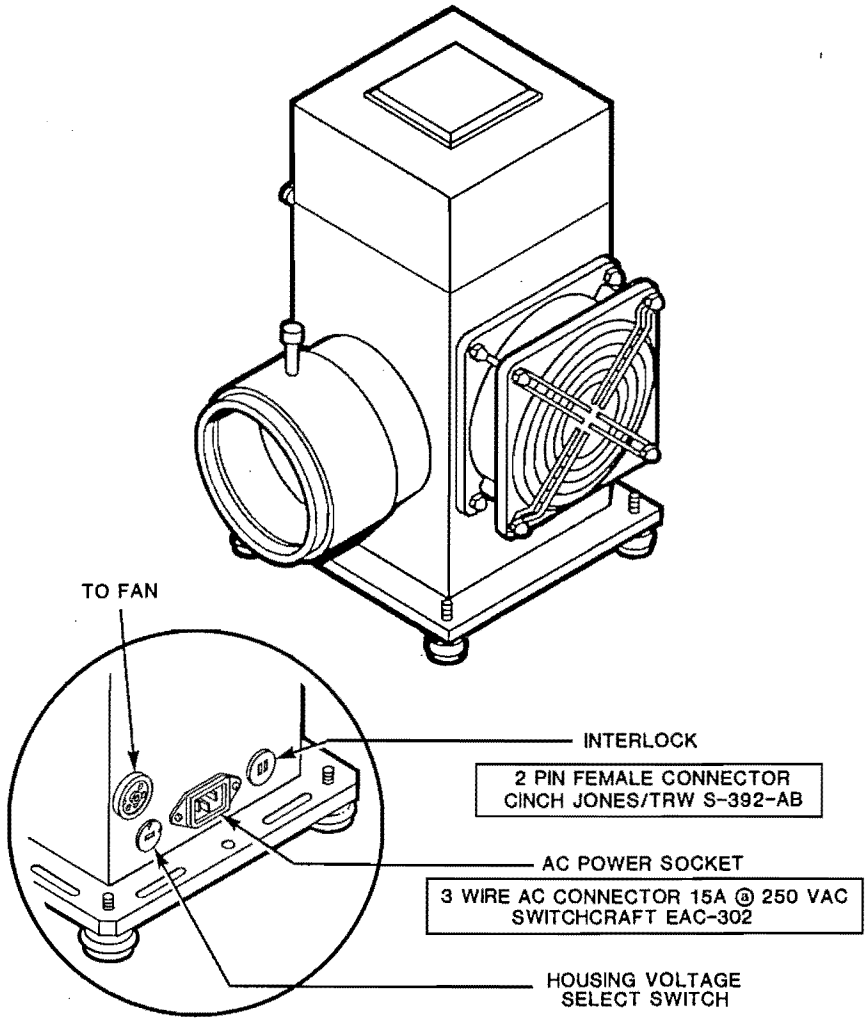

Fig. 2 Safety interlock and electrical sockets.

---

The fan has a combination logic/thermostat control system. The fan will run as long as there is an output voltage from the power supply over 5 VDC, and as long as the temperature inside the Lamp Housing is over 104 °F (40 °C).

#### III.4 **SAFETY AND MONITORING FEATURES**

These lamp housings incorporate safety interlocks. When used with an Oriel Power Supply the lamp automatically shuts off if the housing door is opened or the housing overheats. If you use your own power supply, we strongly recommend that you utilize this low voltage interlock system for safety. See Fig. 2 on page 11 for location of interlock.

#### III.5 **ELAPSED TIME INDICATOR**

The Elapsed Time Indicator (ETI) is located on the side of the lamp housing just above the removable access door. It is powered whenever the lamp is ignited. The full scale reading is 2,000 hours, with increments every 200 hours.

The indicating mechanism is an air gap in a column of mercury, which moves from left to right. The column of mercury is enclosed in a shell, which may be removed and reversed to reset the ETI.

#### III.6 **HOUSINGS WITHOUT CONDENSING LENSES**

The 66000 and 66010 Lamp Housings do not have a condenser, and therefore have a large aperture in the front of the housing. Block this aperture with your own condenser or a plate before operating the lamp.

#### III.7 **MOUNTING**

The lamp housings are supplied with four adjustable feet for free standing use. They allow 0.63 inch (16 mm) height adjustment. You can also mount the housing to tables, carriers, or translators with tapped holes on 1 inch or 25 mm centers. To do this you should remove the feet and use the three mounting points and screw slots. If you have a flat enough surface you can unscrew the three mounting pads and use the baseplate directly. See Fig. 3 on page 12 for baseplate dimensions.

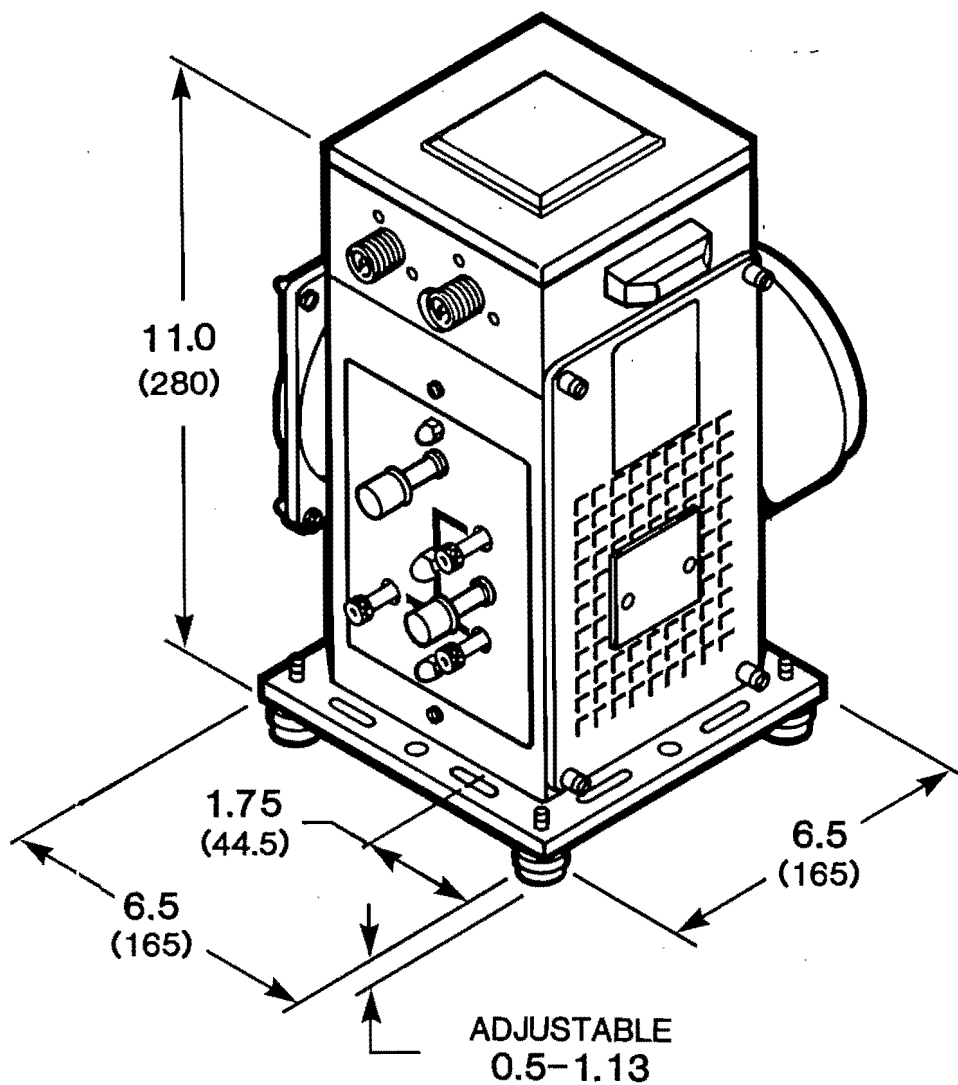

Fig. 3 Dimensional Diagram.

## IV

---

### LAMP INSTALLATION AND INITIAL OPERATION

---

- 1 Check that there is no electrical service to the housing and that the lamp power supply is off and discharged.
- 2 Put on safety goggles and gloves.
- 3 Unscrew the four thumb screws on the side of the housing and remove the access door.
- 4 Determine which orientation is correct for the lamp. For xenon and mercury (xenon) lamps, the anode (+ ve) is at the top. For mercury lamps the anode (+ ve) must be at the bottom. You can identify the anode by a + stamped on the lamp base. Any lamp identification writing or numbers will be the correct way up when the lamp is held in the correct operating orientation. See Fig. 4 on page 15 for a diagram.
- 5 Install the appropriate adapter(s) on the lamp terminal(s). Depending on the lamp type, these socket adapters are fastened to the lamp terminals by set screws or by a threaded connection.

If the lamp is supplied with knurled nuts, remove the bottom nut and discard before installing the socket adapter. One of the knurled nuts will be used to secure the wire lug to the top terminal.

- 6 Connect the top hanging lead to the top terminal, using either the knurled set screw supplied with the lamp, or the knurled set screw supplied with the top adapter.
- 7 Set the lamp position adjusters at approximately mid range. Move the adjusters while watching the bottom mounting block to find mid range. Place the bottom terminal (with adapter) into the bottom mounting block. Adjust the lamp vertically so the arc gap lies approximately in the center of the mirror, then tighten the knurled set screw on the side of the mounting block.
- 8 After the lamp is in position, clean the envelope with alcohol and lint free tissue. Fingerprints left on the lamp may cause the lamp to explode when lit.
- 9 Replace the side access door and tighten the four thumb screws.

- 
- 10 Connect the lamp cables between the lamp housing and the rear of the power supply. + ve cable to "top" for xenon and mercury xenon; + ve cable to bottom for mercury lamps. Read the Power Supply Instruction Manual before operation.

— CAUTION —

BE SURE THE LAMP IS POSITIONED WITH THE PROPER ELECTRODE ON TOP AND THE LEADS ARE CONNECTED TO THE PROPER OUTPUT CONNECTORS OF THE POWER SUPPLY. OPERATION WITH THE WRONG POLARITY WILL IMMEDIATELY DESTROY THE LAMP ELECTRODES.

It is important to re-check the lamp cabling to the lamp housing. If you are operating the lamp housing for the first time or changing lamp type, DO IT NOW. It may save you a lamp. Incorrect connection will result in rapid destruction of the lamp.

- 11 Connect the interlock and ignitor drive cables between the lamp housing and the rear of the power supply.
- 12 Connect the fan power cord to a 110 or 220 VAC line. Make sure the line select switch (located below the fan) is in the appropriate 110/220 V position before plugging the fan in.

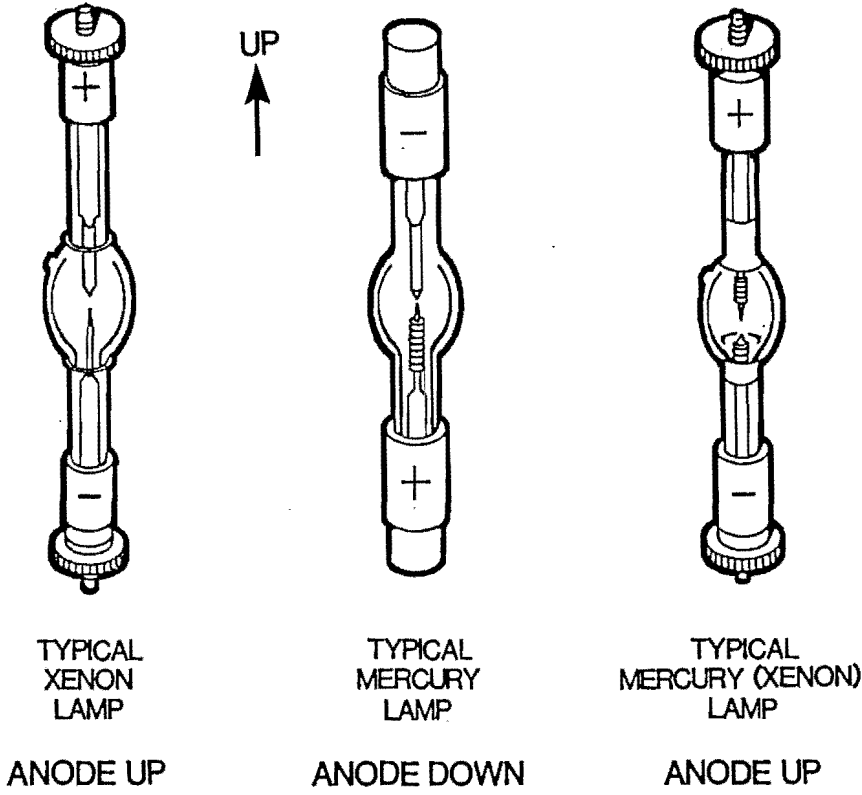

Fig. 4 Correct operating position of arc lamps.

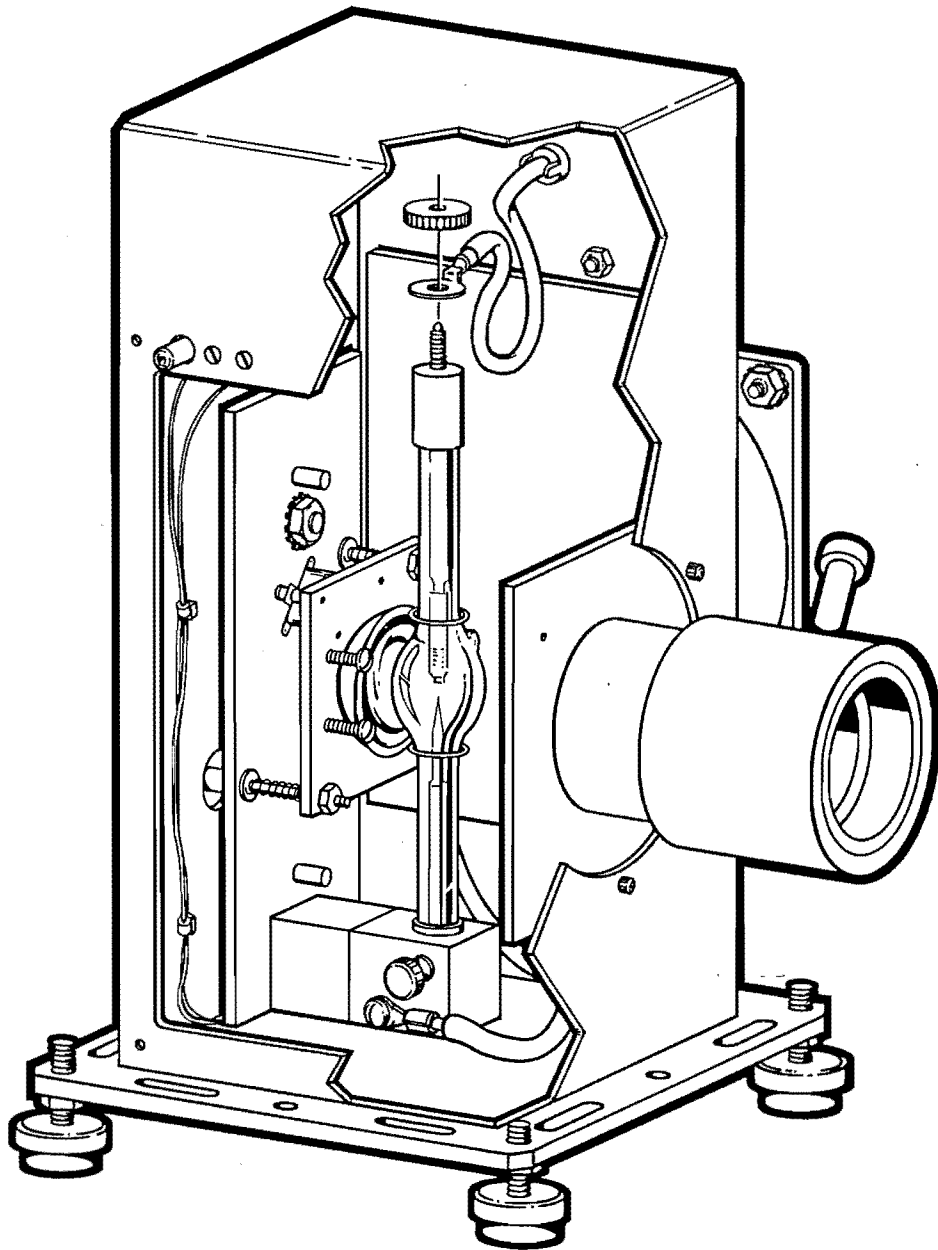

Fig. 5 Arc lamp inside housing.



---

## IV.1 ADJUSTMENT OF LAMP, MIRROR AND LENS

### 1 General

In these housings, the spherical mirror behind the lamp creates an inverted arc image which can be placed onto or near the lamp arc to increase the output beam intensity. The condensing lens collects radiation from both the arc and the mirror image of the arc.

The mirror is adjusted with respect to the lamp by three knobs (smaller) located directly behind the mirror on the back of the housing. The lamp and mirror in unison are adjusted by a vertical and horizontal adjust knob (larger) in the same area. See Fig. 1 on page 10 for location.

### — CAUTION —

|  |
|--|
| DO NOT LET THE MIRROR IMAGE OF THE ARC FALL ONTO EITHER ELECTRODE. OVERHEATING OF THE LAMP SEALS AND SUBSEQUENT LAMP EXPLOSION MAY RESULT. |
|--|

### 2 Adjustments Prior to Operation -

- a Before ignition, roughly adjust the lamp position with the horizontal and vertical adjustment knobs. Adjust the lamp so the arc gap lies approximately in the center of the condensing lens. This can be seen through the lens if the focusing lever on the lens is full back.
- b If you have appropriate safety equipment, ignite and warm up the arc lamp per the instructions in the power supply manual.

### 3 Adjustment During Operation -

- a By adjusting the condensing lens, focus the output beam so an image of the arc appears on a wall or screen. Do not view UV images without safety glasses.
- b Adjust the lamp position to center the output in the condenser lens aperture. You can place a piece of paper over the condenser output and center the beam on the aperture.

- 
- c Rotate the mirror knobs until a bright spot appears alongside the arc. (See Fig. 6 on page 19.) This bright spot is a distorted image of the arc.

Focus the image by rotating all three screws in the same direction concurrently (this translates the mirror back or forth). When focused you will see an inverted image of the arc, about the same size as the arc.

- d Place the mirror image over the main (direct) image (as in Fig. 7 on the following page) or alongside, as desired. You may need to use iterative adjustments to keep a focused mirror image.

— WARNING —

|  |
|--|
| <p>YOU CAN SUPERIMPOSE THE TWO IMAGES, BUT AVOID REIMAGING THE ARC HOT SPOTS ONTO THE ELECTRODES. THIS CAN CAUSE OVERHEATING OF THE LAMP</p> |
|--|

- e Focus the condensing lens as desired.

If additional range of adjustment of the condensing lens is desired:

- a Remove the condensing lens assembly handle (take care to record the orderly assembly of its parts).
- b Slide the inner lens barrel forward or back by hand until another tapped hole appears in the spiral slot.
- c Reassemble the handle into this new hole.

#### 4 Lamp Operation and Cooling -

These arc lamps should be operated close to their rated power. Dropping the power below 80% of rated, can lead to unusual lamp performance, eventual instability, and shortened life. With mercury lamps it can also lead to cooling problems.

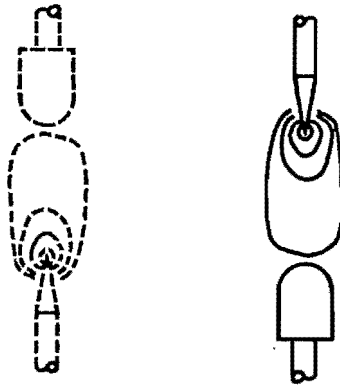

Fig. 6 The electrodes as viewed on a screen in front of the condenser lens are inverted (right). The reflector image as a screen (left) is doubly inverted so the anode of a xenon or mercury (xenon) lamp appears on top.



Fig. 7 Correctly positioned reflector overlays the inverted arc image on the arc gap. The image is the same size as the arc itself.

---

## IV.2 COOLING

### 1 Xenon and Mercury (Xenon) Lamps

Xenon and mercury (xenon) lamps are not sensitive to overcooling. The fan ensures that the lamp terminals and housing skin are at safe temperatures. You can operate 50 W lamps with the fan turned off but not higher rated lamps.

### 2 Mercury Lamps

Mercury lamps include a small amount of mercury and one of the inert gases as inert "starter" gas. The lamp starts as an inert gas arc lamp and then mercury becomes vaporized.

Initially the operating voltage is low and the current high, characteristics of an inert gas arc. As the mercury vaporizes, it starts to dominate the discharge. The arc voltage increases and the current drops to the correct operating level. Sometimes there will also be a sudden change in operating voltage as the arc position moves towards the end of the warm up phase.

The final operating conditions of a mercury arc lamp and how the lamp warms up to these conditions depends critically on the cooling of the lamp. If the lamp is **overcooled** it will take a long time to warm up, and will run at higher current and lower voltage than it should. The light output and lamp life will be reduced. Note that these housings have a thermostat which prevents the fan from switching on until the lamp warms up. This thermostat speeds warm up, but does not prevent overcooling.

If the lamp is **undercooled**, the lamp will warm up quickly, but excessive temperature can damage the lamp seals and lead to destruction. The operating current and voltage of an undercooled lamp are similar to those of a properly cooled lamp. The thermal interlock in these housings prevents undercooled operation. Make sure the interlock is connected.

These Lamp Housings are designed to operate a variety of lamps in normal laboratory ambient. Mercury lamps from different manufacturers differ somewhat in their operating characteristics, and 100 watt mercury lamps have different cooling requirements from 200 watt lamps.

With the fan running it is possible that a mercury lamp will be overcooled and stabilize at lower voltage and higher current than the optimum values. Mercury lamps have varying cooling requirements. You may need to attach the baffle plate (supplied) to the lamp housing fan in order to maintain proper air flow. See Table 1 for this information.

Table 2 shows which lamps require a baffle, and Fig. 8 shows the installation. To install the baffle plate:

- 1 Remove the four screws holding the finger guard and remove the finger guard.
- 2 Install the Baffle Plate as shown in Fig. 8, using the four screws from the finger guard. After installing the baffle recheck the current and voltage characteristics. This information is available in the Volume II catalog.

**Table 2 Lamp Housing Baffles**

| Housing Type | Lamp Type | Operate Fan | Use Baffle |
|--------------|-----------|-------------|------------|
| 50 - 250 W   | 50 W Hg   | No          | No         |
|              | 100 W Hg  | Yes         | Yes        |
|              | 200 W Hg  | Yes         | No         |
|              | 150 W Xe  | Yes         | No         |
| 200 - 500 W  | 200 W Hg  | Yes         | Yes        |
|              | 350 W Hg  | Yes         | No         |
|              | 500 W Hg  | Yes         | No         |

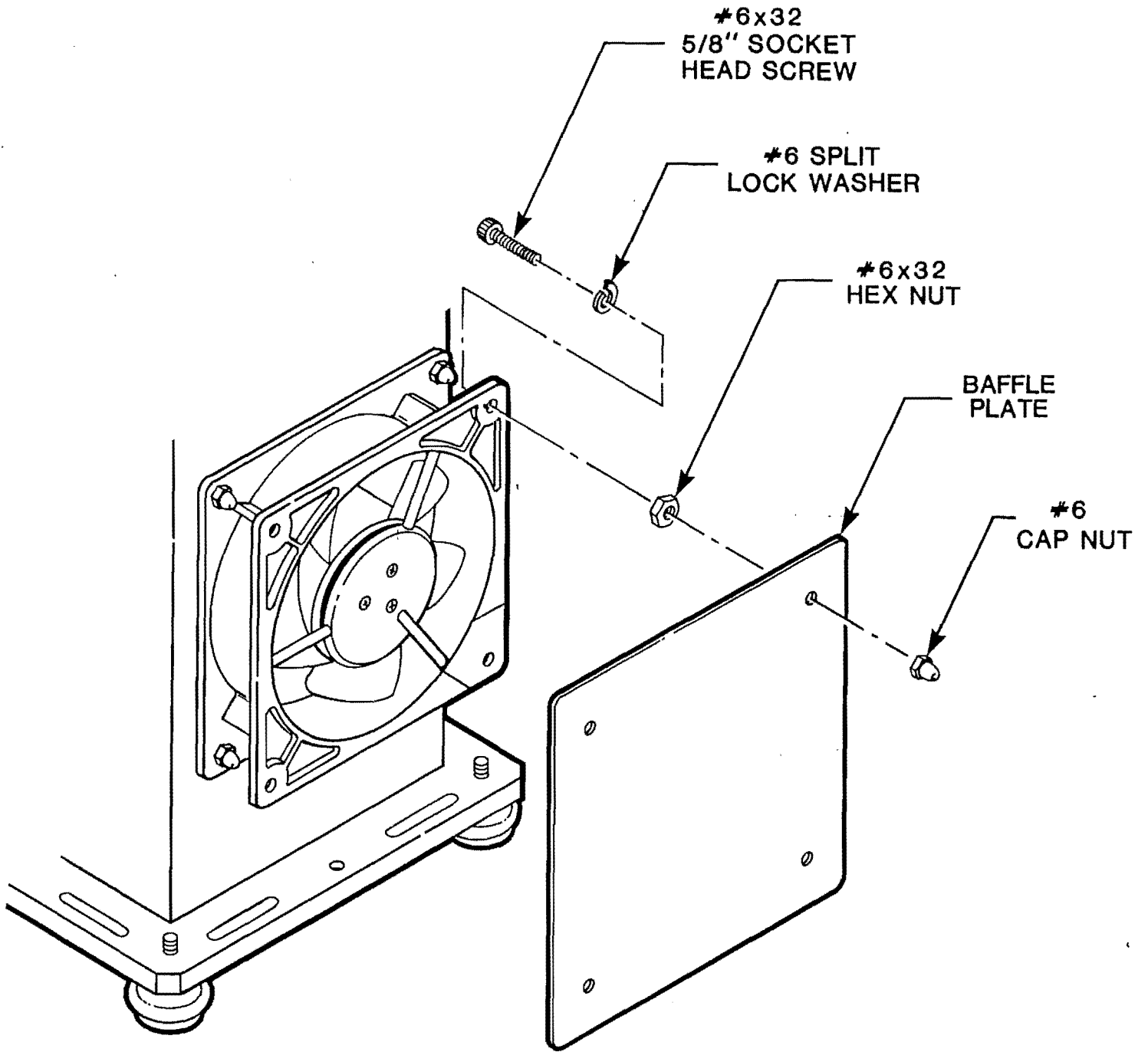

Fig. 8 Installation of Baffle Plate.

## V

---

**LAMP HOUSING OPTICS**

---

Three different types of condenser lenses are available on these Lamp Housings. You can check the lens type on your housing from the listing:

|                 |                                    |
|-----------------|------------------------------------|
| 66000 and 66010 | No condenser                       |
| 66001 and 66028 | F/1.5 condenser                    |
| 66002 and 66011 | F/1 condenser                      |
| 66003 and 66046 | F/0.85 condenser                   |
| 66004 and 66012 | F/0.7 glass/fused silica condenser |
| 66005 and 66013 | F/0.7 fused silica condenser       |

The lenses were designed for efficient collection of light from the arc. In order to get the best performance from your Lamp Housing, we first review some aspects of light collection and then describe how to set the lens position.

By moving the focusing lever you can move the position of the condenser lenses to produce a diverging beam, "collimated beam" or to re-image the arc. The lenses in these housings are designed for collimation rather than imaging. The lens shape and orientation are selected to minimize lens induced distortions (aberration) when the lenses are close to the position which produces a collimated beam (the collimating position). When you use them for imaging, there are two penalties; lens aberrations increase\* and light collection is reduced. For imaging, the lens is moved further from the arc, and so gathers less of the light emitted by the arc within its aperture. The lens operates at a higher F/#.

\*See Volume III for a comprehensive discussion on aberrations.

If you need to image the arc close to the Lamp Housing, or equivalently, produce a small image of the arc, then it is more efficient to use the condenser in the collimating position and use a secondary focusing lens to create the image.

To simplify the discussion, we first describe the operation of an ideal lens and then some of the major results of aberrations.

V.1 COLLIMATED BEAMS

The usual concept of a collimated beam is a parallel cylinder of light. If the intensity is the same anywhere across a section of the cylinder, the beam is uniform. Unfortunately there is no source of a uniform, perfectly collimated beam.

Even expensive laser sources have some residual divergence, in the limit governed by the laws of diffraction, and they usually have non-uniform though sometimes known intensity distributions.

Arc lamp sources with an ideal condenser lens in the collimating position produce beams which depend on the source size and intensity distribution.

A pinhole source at the focus of an ideal lens produces a beam which is close to the ideal collimated beam. In Fig. 9, we show a second pinhole source a distance "d" from the first.

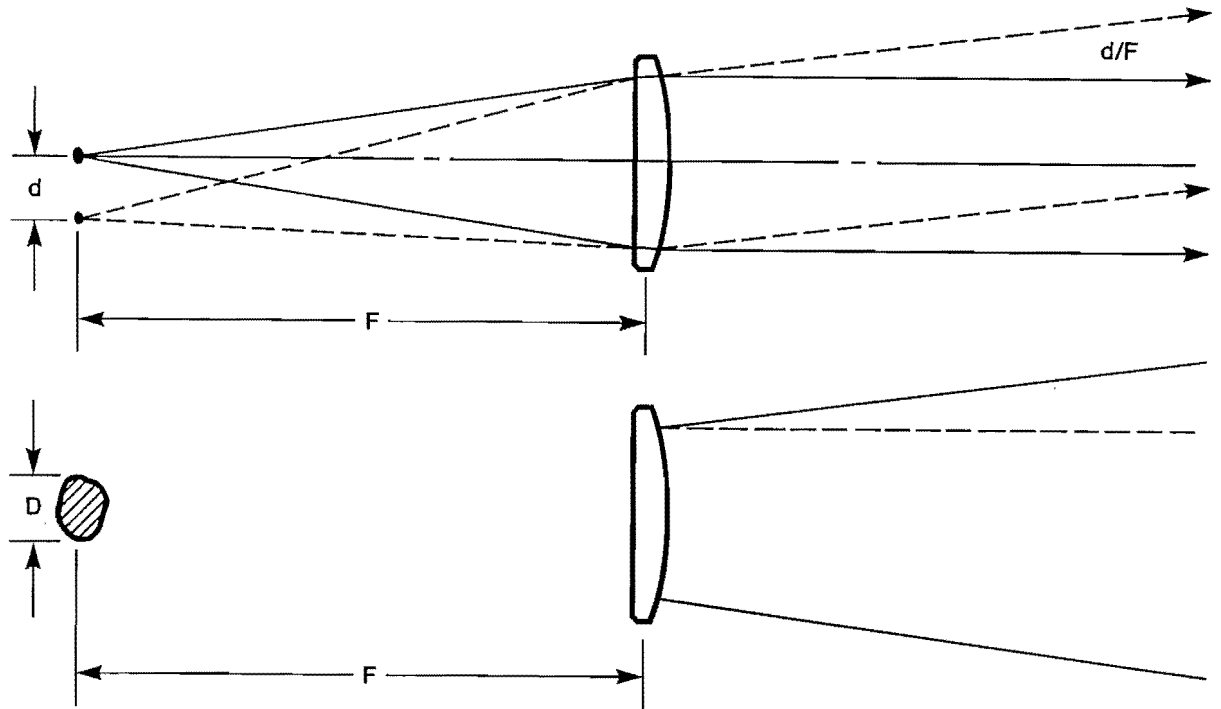

Fig. 9 For most arc sources the divergence in one plane is not the same as that in the orthogonal plane.



The beam from the second pinhole is collimated, but at an angle  $\arctan(d/F)$  with the first. Any extended source can be thought of as a whole set of touching pinholes. The beam after the lens is the sum of all the beams from all the pinholes. It will contain rays with angles up to  $D/F$  where  $D$  is the largest dimension of the source. The beam will have a divergence which depends on the sum of the light from all the points on the source. Obviously this divergence will depend on the size of the source and the intensity of the various "pinholes" or points on the source.

Most arc sources are non-uniform and are not circular. Therefore the divergence in one plane is not the same as that in the orthogonal plane. For most design purposes the arc sizes quoted in Volume II and the lens focal length give a good guide to divergence. For low divergence consider the small arc sources and, if necessary, our Spatial Filter Assembly (Volume II).

## V.2 UNIFORMITY

Arc sources are not uniform and usually have an intensity peak near one electrode. Intensity contours shown in Volume II indicate arc uniformity. The collimated beam comes from pinhole sources which are not equally intense in addition to being spatially distributed. The result is a smooth, non-uniform beam with some divergence. Fig. 10 shows a scan of a collimated beam in the vertical and horizontal planes. The source was a 200 W Hg arc.

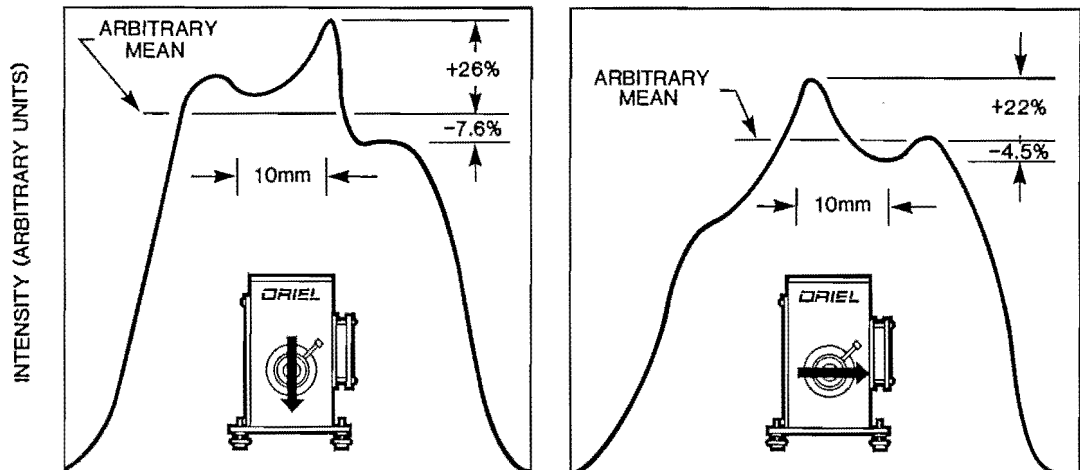

Fig. 10 The collimated output of a 200 W Hg lamp in the vertical and horizontal planes.

V.3 IMAGING THE ARC

You can reimage the arc by positioning the condenser further from the arc using the focusing lever. Volume III describes imaging and provides the formulae. As the condenser lens is moved out, the image moves in and becomes smaller. As already indicated, the lens collects less light as it is moved away from the arc. Additionally, the convergence angle of the beam goes up as the image becomes smaller. This is not usually important for irradiance of a surface, but can be significant if the image is on the slit of a monochromator, optical fiber, or other optical system with limited acceptance angle. We normally use a secondary focusing lens to maximize the light through a slit or into a fiber optic. Fig. 11 shows the higher convergence produced when creating a small arc image.

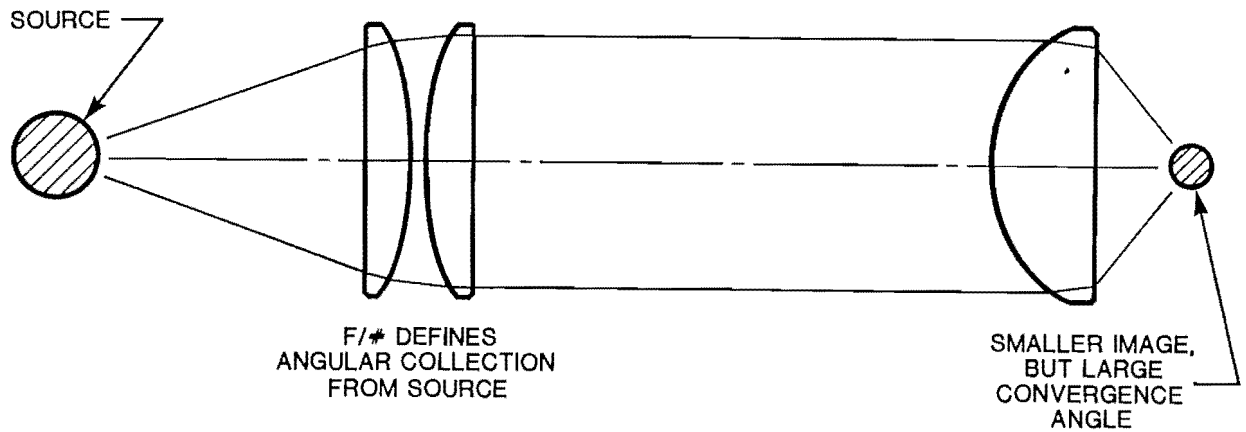

Fig. 11 A source focused to a smaller image.

## V.4 REAL LENS

The condenser lenses are intended for efficient light collection. They operate at low F/#s. As a result the single element F/0.85 and F/1 lenses suffer from severe aberrations, particularly spherical aberration. The doublet F/1.5 lens is somewhat better, while the four element Aspherabs™ are almost free from spherical aberration. Note that all the lenses perform best while collimating the light from the source.

### V.4a Spherical Aberrations

This aberration results from the fact that the ideal lens, the aberration free lens, is not spherical in shape. With the exception of the aspheric condenser, these condenser lenses, like most lenses, have spherical surface shapes for economic manufacturing. In general, spherical aberration is decreased by dividing the refraction, (light bending) as equally as possible between as many surfaces as possible. The lens shapes (plano-convex for the fused silica singlets) of our condensers and orientations minimize spherical aberration for the type of condenser and at the collimating position. The F/0.7 Aspherab™ multi-element lens assembly practically eliminates this aberration by balancing the effects between lenses.

Consider the simple plano convex lens collimating light from an ideal point source. With the plano surface towards the point source and the point source at the (paraxial) focus the marginal rays converge while the paraxial rays are collimated (Fig. 12). This is due to spherical aberration. For the ideal, non-spherical lens shape, the paraxial and marginal rays are all collimated. If the source is located about  $1/4 f$  inside the focus, the paraxial rays diverge slightly and the marginal rays are almost collimated. This is often the optimum compromise for a single element collimating lens (and has the added advantage of collecting more light from the source).

The lens adjustment on these lamp housings allows the lens to be moved closer to the source than the paraxial focus. You can empirically find the best position for your system.

The F/0.7 Aspehrab™ condensing lenses combine negligible spherical aberration and low F/#, and should be used at focus for critical collimating applications.

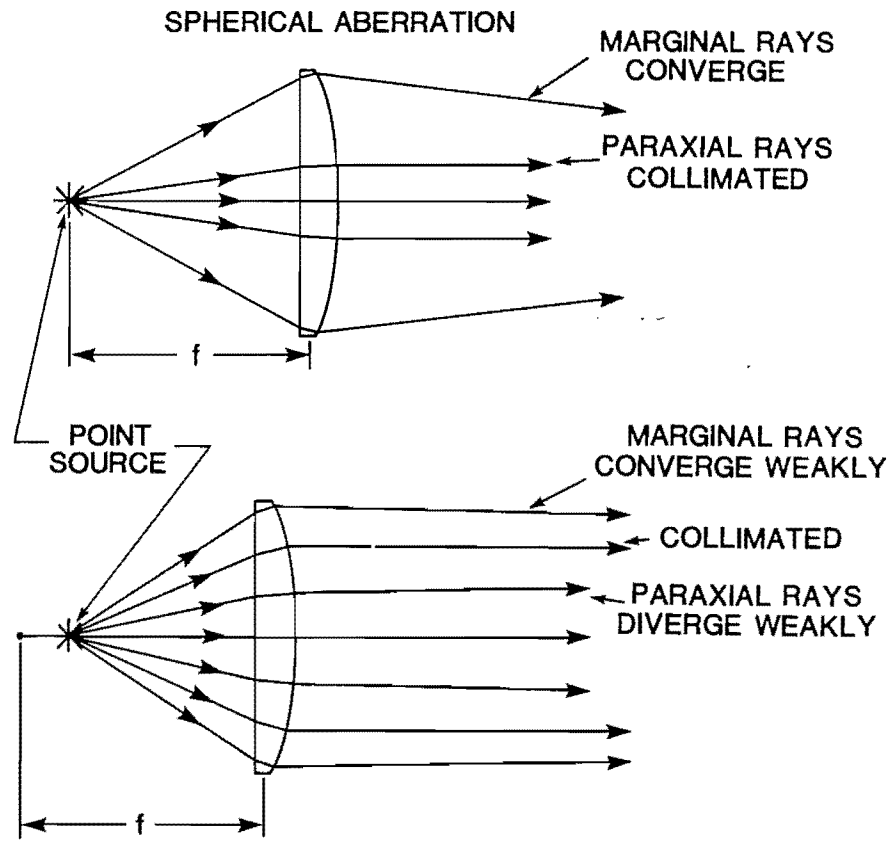

Fig. 12 The marginal rays and the paraxial rays are collimated when the point source is at the paraxial focus, and the plano surface of the lens faces the point source.

V.4b

### Chromatic Aberrations

The term "chromatic aberration" describes the variation of lens focal length with color (Fig. 13). This variation is due to the change in the lens index of refraction ( $n$ ) with wavelength. As the wavelength goes up,  $n$  goes down and the focal length increases.

This causes problems in producing multi-wavelength collimated beams, but is usually a second order effect compared with source and spherical aberration limitations. Chromatic aberration usually becomes significant only when deep UV wavelengths are collimated. The reduction in  $f$  (focal length) for a fused silica lens from the visible value of  $f$  to  $0.91 f$  at 250 nm may require a change of lens for optimum performance. Contact Oriel for details.

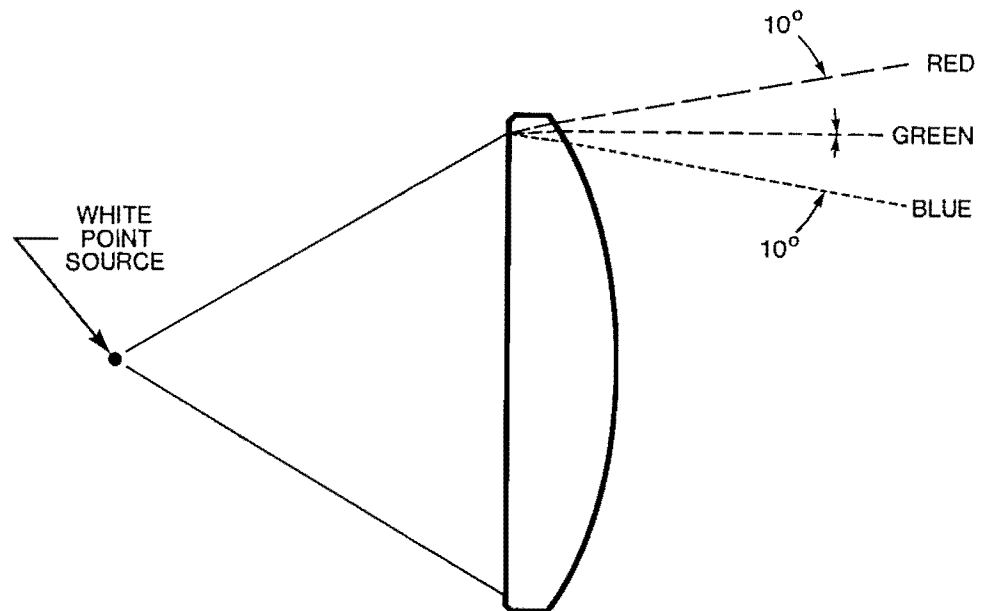

Fig. 13 Chromatic Aberration: different wavelengths are focused at different points.

---

**V.5 HOW DO YOU POSITION THE CONDENSER TO GET A COLLIMATED BEAM?**

You should image the arc on the most distant wall in your laboratory (remembering appropriate safety measures) to get close to the collimation position. You can then move the lens barrel in a small amount for best collimation. If your wall is 2 meters away, a 1.3 mm adjustment is required. For 3 m and 4 m, the corresponding numbers are 0.8 and 0.6 mm.

## VI

---

### CIRCUIT DESCRIPTION

---

Reference: Schematics 66000-2-1001, 68705-2-3101, 68705-2-1111

Electronic circuitry is located in the lamp housing to perform three functions: ignite the arc lamp, control the cooling fan, and run the elapsed time indicator. A fourth function, which is non-electronic, is the interlock circuit which disables the power supply output whenever the access door is open, or the temperature inside the housing is excessive.

#### VI.1 IGNITION CIRCUIT

The ignition circuit, or ignitor, is contained on circuit card 68705-3-3100 and transformer 68705-3-1200. The power supply outputs (J6 and J7) connect to lamp housing connectors J2 and J3. J2 then is connected through the secondary of T2, the ignitor transformer, to the top electrode of the arc lamp. J3 is connected to the bottom electrode. Capacitor C1 filters and keeps the high voltage ignition pulse from appearing across the power supply output terminals.

The ignitor drive output from the power supply is a 100 Vp-p, 25 kHz square wave signal. It is connected in via J1 to the primary of transformer T1.

When the 100 V square wave signal is present, 1500 V is available at the high voltage secondary winding. The 1500 V square wave is rectified through a full wave bridge, consisting of CR1 through CR4. The output of the bridge is a full 1500 V DC, which charges C2 through R1 at a fast rate.

The charge across C2 is also present (through the T2 primary) across the spark gap, MP1. The spark gap is a sealed gap with a breakdown level of approximately 1,400 V. When the spark gap breaks down (arcs across), it discharges C2 through the primary winding of the ignitor transformer T2. The ignitor transformer has a turns ratio of approximately 1:33, so the 1400 V input causes a 35 kV output pulse which ignites the arc lamp.

#### VI.2 COOLING FAN CONTROL CIRCUIT

The electronic circuitry which turns on the cooling fan is located on the piggy-back circuit card 68705-2-1110. Bridge rectifier CR1 is connected across the power supply output lines. Whenever there is an output from the power supply there is a DC potential across the + and - terminals of CR1. The DC potential causes a current flow through opto-isolator CR4. Whenever there is current flow through opto-isolator CR4, its output resistance drops drastically and triac Q3 is biased on, turning on power to the cooling fan. As long as there is over 5 V of output from the power supply, the cooling fan will turn on.

---

Once the lamp has been ignited and the housing has heated up beyond 40 °C, thermostat S4 will close, shorting out triac Q3. After the power supply has been turned off, the cooling fan will continue to run until the temperature inside the lamp housing falls below 40 °C.

### VI.3 ELAPSED TIME INDICATOR DRIVE CIRCUIT

The electronic circuitry which controls the Elapsed Time Indicator (ETI) is located on the piggy-back circuit 68705-2-1110.

The pre-ignition output voltage from the power supply is significantly higher than the lamp running output voltage from the power supply. The xenon diode CR2 is used to sense the difference between pre-ignition voltage and lamp running voltage. When pre-ignition voltage is present, CR2 conducts and transistor Q1 is turned on.

When transistor Q1 is turned on, it shunts the output current from opto-isolator CR5, and the ETI is not activated. When transistor Q1 is turned off, current flows through CR5, lowering its output resistance and turning on triac Q4. Triac Q4 drives AC power to the elapsed time indicator.

### VI.4 INTERLOCK CIRCUIT

The interlock circuit consists of the series loop of door switch S2 and thermostat S3. They are connected to a 2-pin connector J5, which in turn is connected to the power supply.

Whenever the interlock circuit is opened, the output drive from the arc lamp power supply is disabled. When this happens, any DC voltage on the filter capacitors discharges through both internal and external resistance paths, and the ignition drive waveform is disabled.

The interlock circuit is opened whenever the side access door is opened (S2) or whenever the temperature inside the lamp housing becomes excessive (S3) (125 °C).



## VII

---

### TROUBLESHOOTING

---

#### VII.1 INTRODUCTION

This section deals with procedures to follow if you encounter specific difficulties in operating these Lamp Housings. Additional details for repairing the Lamp Housing circuitry are available from Oriel, but in general we do not advise attempting to work on the circuitry as this could expose you and your equipment to the high ignition voltage.

#### VII.2 PROBLEMS

##### 1 Lamp will not light after several repeated presses of the "lamp start button".

The most common problem experienced when using these Lamp Housings is difficulty in starting the lamp. The problem may be in the Lamp Housing, in the Power Supply, or with the lamp. The following procedure should help you identify the problem area. If you cannot locate the source of the problem, and do not have other Lamp Housings or Power Supplies to interchange as a problem finding technique, we recommend you send **the complete system**, Power Supply, Lamp Housing and lamp to Oriel for diagnosis of the failure mode.

##### Recommended Procedures:

- 1 Check that the Power Supply is operating - power breaker light, and fan.
- 2 Check that there is pre-ignition voltage available from the Power Supply.

Move the toggle switch on the Power Supply to the voltage position and check that there is an open circuit voltage of more than 80 V for xenon/mercury (xenon) supplies, or 120 V for mercury supplies. If not, check the interlock circuit. If there is no pre-ignition voltage then the interlock circuit may not be closed.

- 3 Check the Interlock circuit.

First, check that the door of the Lamp Housing is fully closed thus activating the door switch. This may cure the problem. If not, check the Interlock fully. You can do this by using a shorted interlock plug to plug into the Power Supply. If you do not have a shorted plug, remove the plug from the Lamp Housing and short the terminals using wire. Check for pre-ignition voltage. If there is no voltage then there is a problem with the Power Supply. If the voltage is present using the shorted plug but is not there when you connect the interlock to the Lamp Housing then there is a problem with the Lamp Housing interlock circuitry.

---

The simple circuit is located inside the Lamp Housing. After removal of all power (lamp and fan power), check inside the housing for a broken wire or thermostat which is jammed open. (There are two thermostats in the housing, one, normally closed, is marked NC. This is the thermostat to check.)

If you cannot trace the fault, contact Oriel for advice. Do not operate the Lamp Housing with a defeated interlock.

- 3 Check the main power connections to the Lamp Housing and Power Supply.
- 4 Check the ignitor connections.
- 5 Check the lamp and the internal connections to the lamp.  
Remove the lamp and fan power from the Housing, open the Lamp Housing and check the lamp and that the contacts are properly tight. You may need to remove the lamp and examine it. Assuming no catastrophic damage, then check for cracks in the lamp or lamp stem. Examine the molybdenum strip conductors inside the lamp stem for continuity. Small breaks in these conductors will prevent lamp operation. Examine the electrodes for excessive "burn back" or rounding. If the lamp has a trigger wire, then check that it is properly attached. If it is a xenon or mercury(xenon) lamp, and it does not have a trigger wire, and you would like to attach one, follow these procedures:
  - a Use a high temperature nichrome wire, AWG 28, with an OD of 0.315 mm.
  - b Wearing cots or gloves loop the wire around the top of the lamp envelope, (A) in Fig. 14, twisting the end securely.
  - c Bring the wire down the side of the envelope, (B), nearest to the vacuum "fill/breakoff" mark. Keep the wire snug against the glass.

- d Loop the wire around the bottom of the envelope (C), and twist the end to ensure it does not slide.

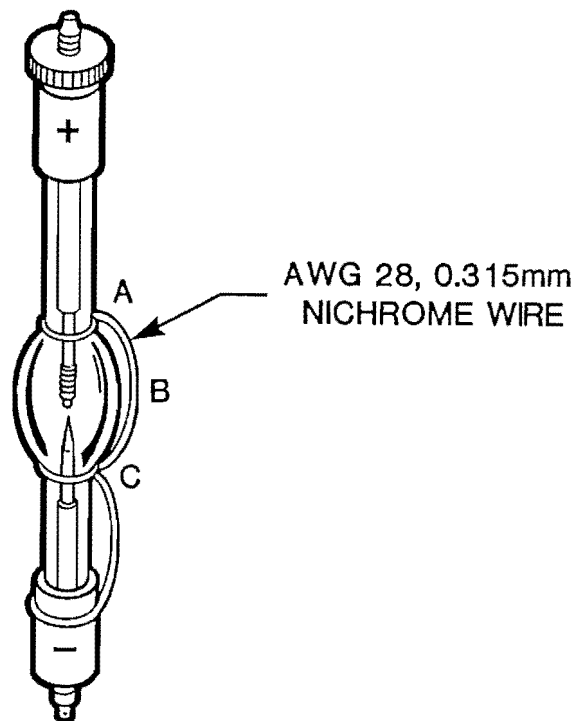

Fig. 14 Starter wire installation on Xe lamp.

6 Check for ignition.

If all the connections are properly made and the lamp seems fine then place a piece of paper near the output of the condenser lens and if possible darken the room. Use safety goggles and view the paper while pressing the start button. What you see will help isolate the problem.

- a A dim flash, and brief snapping noise indicates that the ignitor is breaking down the lamp, but that the main capacitor is not dumping. This indicates that the power supply ignitor drive circuit is working but there is inadequate break down, due either to a problem with the DC output section of the power supply or a lamp problem.

- b A brighter flash indicates that the ignitor is breaking down the lamp and the power supply is dumping the output capacitor, but that the power supply is failing to sustain the discharge. The ignitor is operating properly, the lamp or power supply are suspect.
- c No flash, and no "snap" at all indicates the ignitor or the power supply ignitor circuit is not working. The ignitor itself, the cabling to the power supply, or the ignitor drive circuitry in the Power Supply is at fault. You can check for ignitor drive signal from the power supply by monitoring the plug at the Lamp Housing end of the ignitor drive cable. Detach the cable from the Lamp Housing and connect a high impedance AC voltmeter across the pins shown in Fig. 15. When you press the "lamp start button", the meter should register some tens of volts. The exact value depends on the meter impedance and how it arrives at the root mean square value displayed. If the voltage is present then the Lamp Housing ignitor is malfunctioning. If the voltage is not present then the power supply ignitor drive circuitry is malfunctioning. You should return the Lamp Housing to Oriel for repair or replacement.

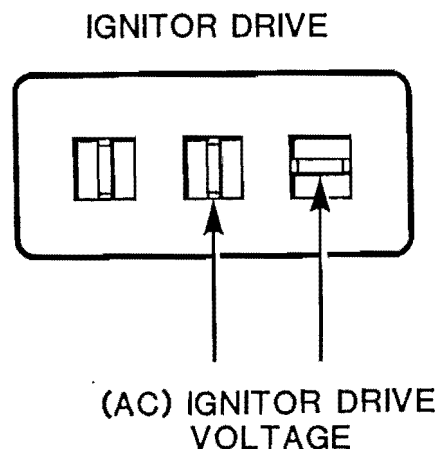

Fig. 15 Ignitor Drive Plug.

---

**2 The Lamp Housing Fan falls to operate.**

The Lamp Housing Fan should operate as soon as the power supply is turned on.

Recommended Procedure

- 1 Check that the Lamp Housing power cable has power, and that the line switch 110/220 is set correctly. If the fan still fails to operate, then call Oriel for further assistance.

**3 Mercury lamps do not reach the correct current/voltage.**

If a mercury lamp is not running at the correct temperature, it will not reach the correct current/voltage. If the lamp is running at its rated power but the lamp current is too high and the voltage is too low, the lamp is being overcooled. If the lamp is running at its rated power but the lamp voltage is too high and the current is too low, it is being undercooled.

Recommended Procedure:

- 1 Check that the fan is baffled as described in the section on lamp cooling, page 21.
- 2 Check that there are no obstructions to airflow in front of the fan.

**4 You cannot image the arc properly some distance from the Lamp Housing.**

Normally you should be able to image the arc on a surface some feet or meters away from the Lamp Housing by simply adjusting the condenser lens position. You should also be able to adjust the lamp position to center the beam in the condenser barrel output aperture.

Recommended Procedure

- 1 If you cannot image the arc, remove all power from the Lamp Housing, allow the lamp time to cool, and then check for a broken condenser lens. Open the Lamp Housing and check the vertical position of the lamp. The arc gap should be positioned in the center of the reflecting mirror. If you have the appropriate adapters for your lamp you should be able to position it correctly. If not, call Oriel for further information.

---

**5 You cannot image the arc close to the Lamp Housing.**

You should not have a problem imaging the arc some feet or meters away from the Lamp Housing. You may have problems imaging the arc close to the housing because the condenser lens adjustment does not allow the condenser to be located in an appropriate position. As you move the lens out, the image plane moves towards the lens. The closest image plane is determined by how far out you can move the lens.

**Recommended Procedure**

- 1 There are three tapped holes in the lens barrel to allow you to change the lens adjustment range. Remove the handle, carefully noting the location of each small part, and reassemble it with the screw in a different position to change the focus range. For reimaging close to the Lamp Housing, the screw should be in the hole closest to the front (output) of the lens barrel. Note that using a secondary focusing lens is often a better approach.

---

## WARRANTY AND RETURNS

---

### WARRANTY

Oriel Corporation warrants that all goods described in this manual (except consumables such as lamps, bulbs, filters, ellipses, etc.) shall be free from defects in material and workmanship. Such defects must become apparent within the following period:

1. All products described here, except spare parts: one (1) year or 3000 hours of operation, whichever comes first, after delivery of the goods to buyer.
2. Spare parts: ninety (90) days after delivery of goods to buyer.

Oriel Corporation's liability under this warranty is limited to the adjustment, repair and/or replacement of the defective part(s). During the above listed warranty period, Oriel Corporation shall provide all materials to accomplish the repaired adjustment, repair or replacement. Oriel Corporation shall provide the labor required during the above listed warranty period to adjust, repair and/or replace the defective goods at no cost to the buyer ONLY IF the defective goods are returned, freight prepaid, to an Oriel Corporation designated facility. If goods are not returned to Oriel Corporation, and user chooses to have repairs made at their premises, Oriel Corporation shall provide labor for field adjustment, repair and/or replacement at prevailing rates for field service, on a portal-to-portal basis.

Oriel Corporation shall be relieved of all obligations and liability under this warranty if:

1. The user operates the device with any accessory, equipment or part not specifically approved or manufactured or specified by Oriel Corporation unless buyer furnishes reasonable evidence that such installations were not a cause of the defect. This provision shall not apply to any accessory, equipment or part which does not affect the safe operation of the device.
2. The goods are not operated or maintained in accordance with Oriel's instructions and specifications.
3. The goods have been repaired, altered or modified by other than Oriel authorized personnel.
4. Buyer does not return the defective goods, freight prepaid, to Oriel repair facility within the applicable warranty period.

IT IS EXPRESSLY AGREED THAT THIS WARRANTY SHALL REPLACE ALL WARRANTIES OF FITNESS AND MERCHANTABILITY. BUYER HEREBY WAIVES ALL OTHER WARRANTIES, GUARANTIES, CONDITIONS OR LIABILITIES, EXPRESSED OR IMPLIED, ARISING BY LAW OR OTHERWISE, WHETHER OR NOT OCCASIONED BY ORIEL'S NEGLIGENCE.

This warranty shall not be extended, altered or varied except by a written document signed by both parties. If any portion of this agreement is invalidated, the remainder of the agreement shall remain in full force and effect.

### CONSEQUENTIAL DAMAGES -

Oriel Corporation shall not be responsible for consequential damages resulting from misfunctions or malfunctions of the goods described in this manual. Oriel's total responsibility is limited to repairing or replacing the malfunctioning or malfunctioning goods under the terms and conditions of the above described warranty.

### INSURANCE -

Persons receiving goods for demonstrations, demo loan, temporary use or in any manner in which title is not transferred from Oriel, shall assume full responsibility for any and all damage while in their care, custody and control. If damage occurs, unrelated to the proper and warranted use and performance of the goods, recipient of the goods accepts full responsibility for restoring the goods to their condition upon original delivery, and for assuming all costs and charges.

### RETURNS

Before returning equipment to Oriel for repair, please call the Customer Service Department at (203) 377-8282. Have your purchase order number available before calling Oriel. The Customer Service Representative will give you a Return Material Authorization number (RMA). Having an RMA will shorten the time required for the repair, because it ensures that your equipment will be properly processed. Write the RMA on the returned equipment's box. Equipment returned without a RMA may be rejected by the Oriel Receiving Department. Equipment returned under warranty will be returned with no charge for the repair or shipping. Oriel will notify you of repairs not covered by warranty, with the cost of the repair, before starting the work.

Please return equipment in the original (or equivalent) packaging. You will be responsible for damage incurred from inadequate packaging, if the original packaging is not used.

Include the cables, connector caps and antistatic materials sent and/or used with the equipment, so that Oriel can verify correct operation of these accessories.

---

## **DRAWINGS**

---

The following drawings and parts lists are enclosed with this manual:

### **SCHEMATICS**

66000-2-1001, Top Assembly  
68705-2-3101, Ignitor  
68705-2-1111, Elapsed Time Drive

### **PARTS LISTS**

68705-3-3100, Ignitor Card  
68705-2-1110, Elapsed Time Drive Card



# ORIEL CORPORATION ASSEMBLY PARTS LIST

|                    |      |
|--------------------|------|
| RELEASE #          |      |
| PAGE 1             | OF 2 |
| REV. DATE: 4/12/88 |      |
| ERR # 10311        |      |

| MODEL or ASSEMBLY NUMBER: 68705-2-1110 |                       |          |           | DWG./SCHEM. NUMBER                  | P/L REV.                        | REV. DATE: 4/12/88 |                      |
|--|-----------------------|----------|-----------|-------------------------------------|---------------------------------|--------------------|----------------------|
| NAME: ASSEMBLY, ELAPSED TIME DRIVE     |                       |          |           |                                     | H                               | ERR # 10311        |                      |
| ITEM #                                 | SCHEMATIC DESIGNATION | P/L SUB. | DWG. SIZE | ORIEL PART NUMBER OR DRAWING NUMBER | DESCRIPTION                     | QTY.               | MFG. PACKAGING NOTES |
| 1                                      |                       |          | B         | 68705-2-1113                        | P.C. BOARD                      | 1                  |                      |
| 2                                      |                       |          |           |                                     | SOLDER CUP                      | 2                  |                      |
| (A) 3                                  |                       |          |           | 20-50-046                           | SPACER, SNAP-ON 1/2" LONG       | 3                  |                      |
| 4                                      | Q1                    |          |           | 50-10-005                           | TRANSISTOR, 2N4123              | 1                  |                      |
| (B) 5                                  |                       |          |           |                                     |                                 |                    |                      |
| (C) 6                                  | Q3,4                  |          |           | 50-40-010                           | TRIAC T2300B                    | 2                  |                      |
| 7                                      | CR1                   |          |           | 50-20-040                           | BRIDGE, MDA 102A                | 1                  |                      |
| (F) 8                                  | CR2                   |          |           | 50-20-005                           | DIODE, ZENER.18V,IN4746         | 1                  |                      |
| (B) 9                                  |                       |          |           |                                     |                                 |                    |                      |
| 10                                     | CR4,5                 |          |           | 52-10-007                           | ISOLATOR, CLM8600               | 2                  |                      |
| (F) 11                                 | R5,6                  |          |           | 52-05-104                           | RESISTOR, 100K OHMS 1/4W        | 2                  |                      |
| 12                                     | R1                    |          |           | 35-05-333                           | RESISTOR, 33K OHMS 1/4W         | 1                  |                      |
| (FB) 13                                | R2                    |          |           | 35-05-472                           | RESISTOR, 4.7K OHMS 1/4W        | 1                  |                      |
| (B) 14                                 |                       |          |           |                                     |                                 |                    |                      |
| 15                                     | C1                    |          |           | 05-2-5028                           | CAPACITOR, .005 mf 3KV          | 1                  |                      |
| (H) 16                                 | J1                    |          |           | 10-30-078                           | CONNECTOR, 5 PIN MALE POL. LOCK | 1                  | plno.2               |



# ORIEL CORPORATION ASSEMBLY PARTS LIST

RELEASE #  
PAGE 1 OF 2

MODEL or ASSEMBLY NUMBER: 68705-3-3100 DWG./SCHEM. NUMBER P/L REV. REV. DATE: 11-7-86  
 NAME: IGNITOR BOARD 68705-3-3100 C D ERR # 9639

| ITEM # | SCHEMATIC DESIGNATION | P/L SUB. | DWG. SIZE | ORIEL PART NUMBER OR DRAWING NUMBER | DESCRIPTION                        | QTY. | MFG. PACKAGING NOTES |
|--------|-----------------------|----------|-----------|-------------------------------------|------------------------------------|------|----------------------|
| 1      |                       |          | C         | 68705-3-3103                        | PRINTED CIRCUIT BOARD              | 1    |                      |
| C 2    | T1                    | P/L      |           | 68705-2-1020                        | TRANSFORMER, HIGH VOLTAGE          | 1    |                      |
| 3      | C2                    |          |           | 05-06-1047                          | CAP. .1UF 1600V AXL                | 1    |                      |
| 4      | CR1-CR4               |          |           | 50-20-029                           | DIODE                              | 4    |                      |
| 5      | R1                    |          |           | 35-25-105                           | RESISTOR, 1 MEG $\Omega$ , 1W, 10% | 1    |                      |
| 6      | C1                    |          |           | 05-2-5028                           | CAP. .005UF 3KV                    | 1    |                      |
| 7      | MP1                   |          |           | 50-80-142                           | SURGE VOLTAGE PROTECTOR            | 1    |                      |
| 8      |                       |          |           |                                     |                                    |      |                      |
| 9      | R2                    |          |           | 37-05-9534                          | RESISTOR                           | 1    |                      |
| 10     | A                     |          |           |                                     |                                    |      |                      |
| 11     |                       |          |           | 60-40-032                           | SPACER PRINTED CIRCUIT BOARD       | 2    |                      |
| 12     |                       |          |           | 60-35-015                           | TERMINAL                           | 10   |                      |
| C 13   |                       |          |           |                                     |                                    |      |                      |
| C 14   |                       |          |           |                                     |                                    |      |                      |
| 15     |                       |          |           |                                     | 6-32 X 5/8 PAN HD SCREW            | 2    |                      |
| 16     |                       |          |           |                                     | NUT "KEP" #6-32                    | 6    | plno.9               |



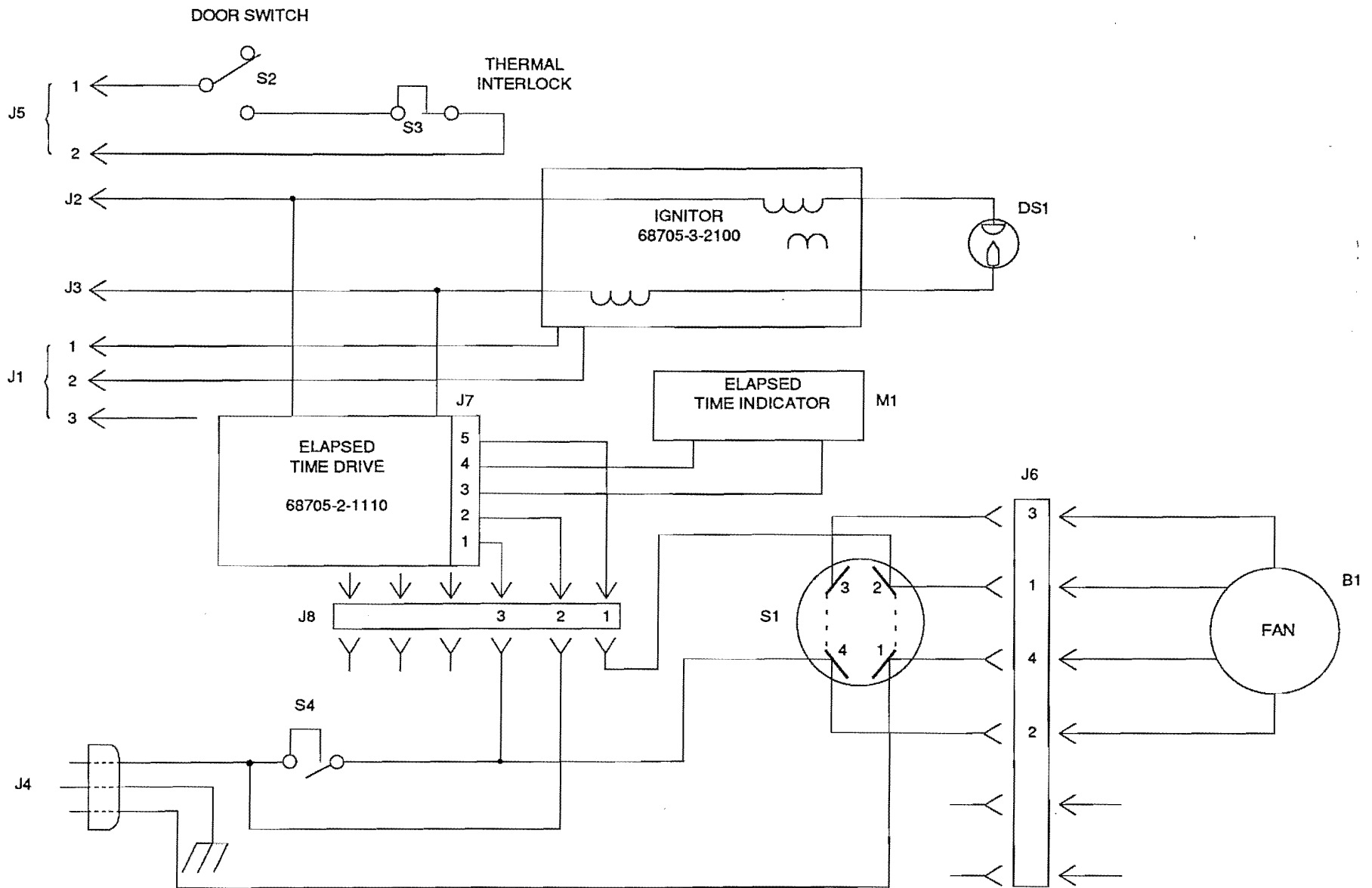

250 W/500 W  
ARC LAMP HOUSING SCHEMATIC  
66000-2-1001

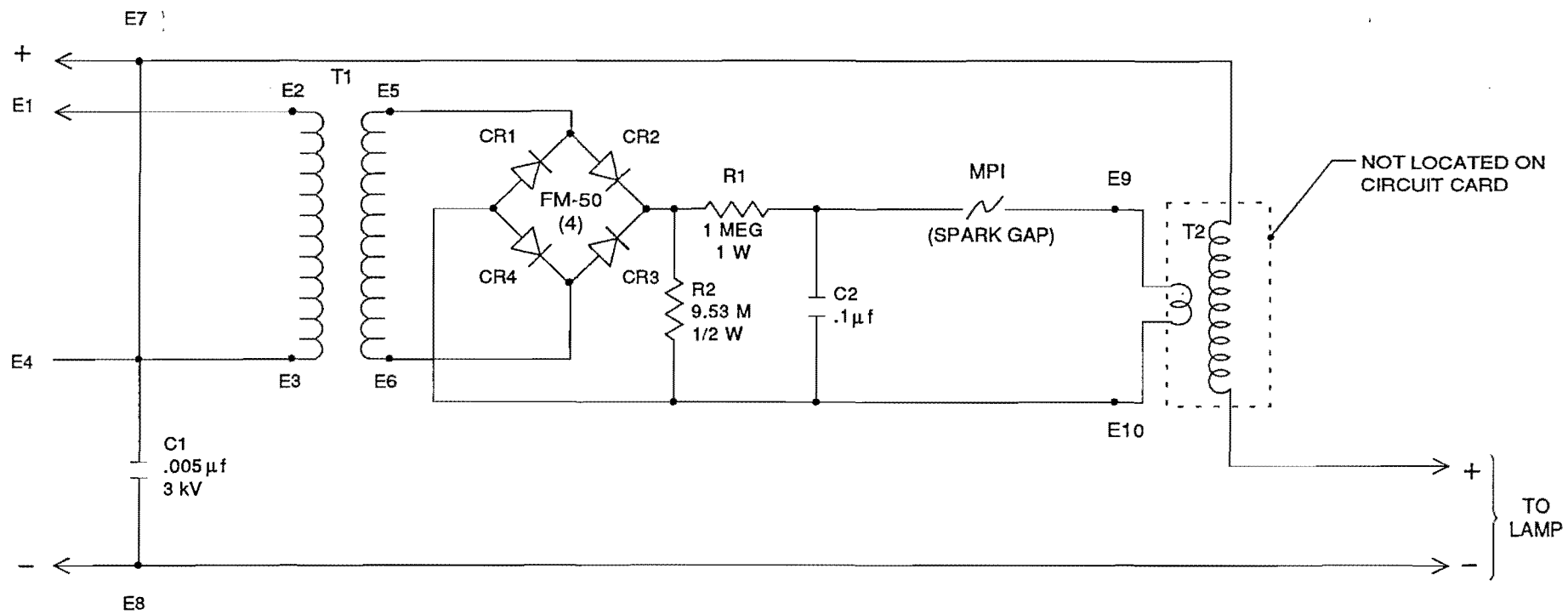

IGNITOR SCHEMATIC  
 68705-2-3101

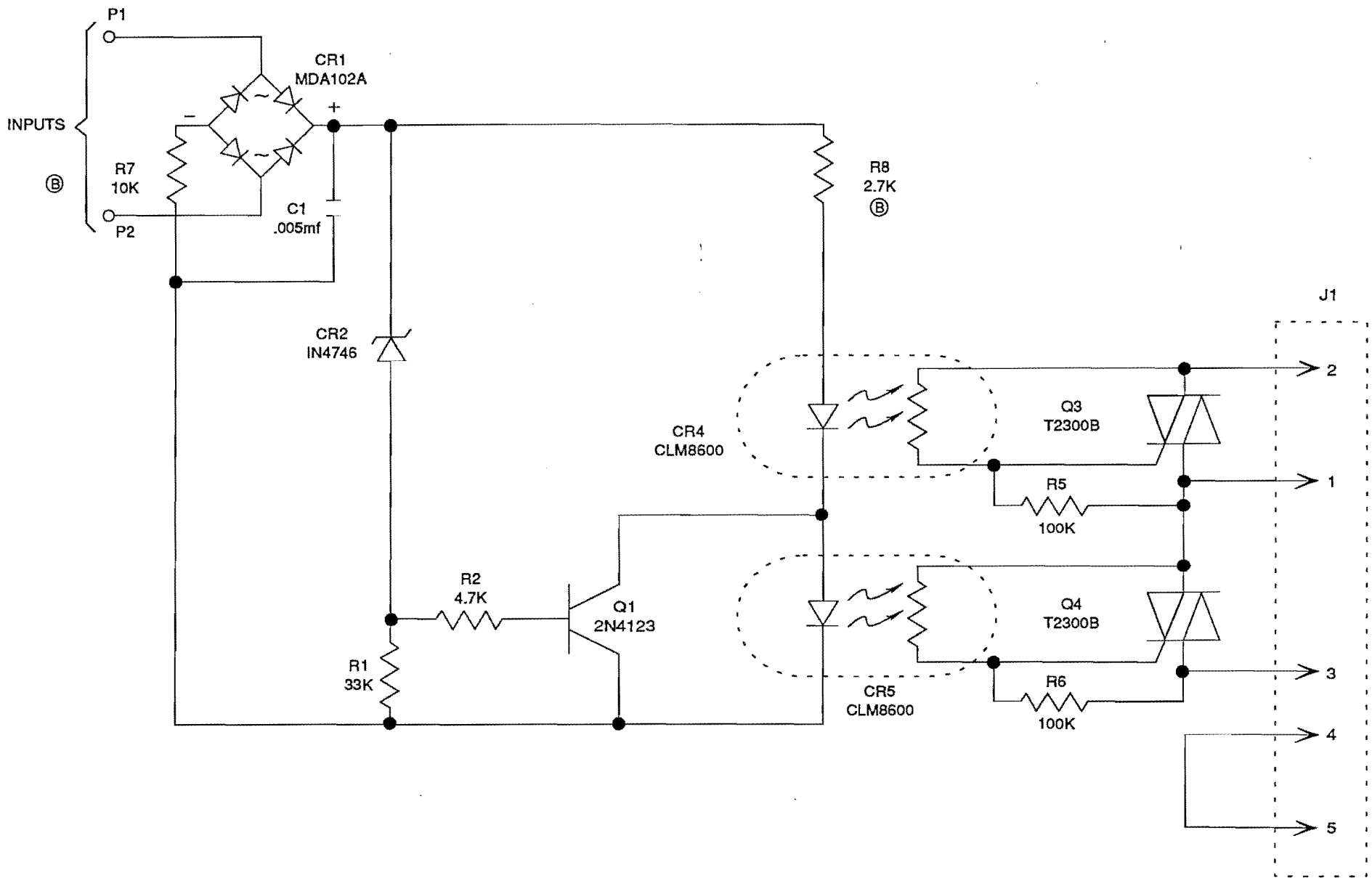

NOTE:  
 1. UNLESS OTHERWISE SPECIFIED ALL  
 RESISTORS 1/4 WATT.

ELAPSED TIME DRIVE  
 SCHEMATIC  
 68705-2-1111