

INSTRUCTION MANUAL

EW SERIES

MODEL: PS/EW10N60.0-11

SERIAL #: M828707-01

DATE:

7/11/96

Our Glassman is a
Model SP/WG-10N30
SN M348220-02BC900718

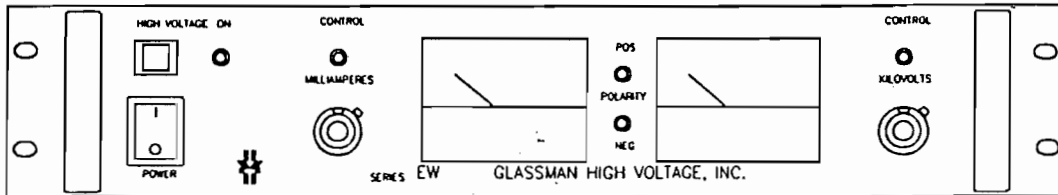

Innovations in high voltage power supply technology.

GLASSMAN HIGH VOLTAGE INC.

Route #22 East, Salem Industrial Park, P.O. Box 551

Whitehouse Station N.J. 08889

TABLE OF CONTENTS

EW SERIES

	Page
Warranty/User Registration Card.....	i
SECTION I. DATA SHEET	1
Features	1a
Specifications, Models and Outline	1b
SECTION II. GENERAL INFORMATION	2
Unpacking and Inspection	2
Correspondence	2
Connections/Controls Description	3
Installation and Operation	6
Polarity Reversal - Models greater than 5kV	9
Polarity Reversal - Models 5kV or less	10
Remote Control Interface	10
SECTION III. SCHEMATIC AND ASSEMBLY DRAWINGS	



Instructions for Model ER Glassman

The new ER model Glassman has a different interlock structure than the WG series. Surface Science Instruments modified the WG by installing a relay inside the WG power supply and adding a 3 pin connector on the back panel. The simplest way to provide 10KV interlock is to provide an external relay. The SPI adapter contains this relay.

To install adapter follow the steps.

1. Remove the existing 10KV interlock form J4 on the back panel of the 8702 X-ray gun controller.
2. Connect the cable marked 10KV interlock on the new adapter to J4 on the 8702.
3. Remove the 10KV Shut-down cable from pins 2 and 3 of the old Glassman. The cable could have been connected to pins 1 and 3. This is not an issue since pins 1 and 2 are connected together. The other end of the 10 KV Shut-down cable is connected to the 8710 Manual Vacuum Controller J3.
4. Connect one wire in the 10KV Shout-down cable to the RED wire in the cable coming from the HV interlock adapter. See figure below. Use crimp connector supplied.
5. Connect the spade lug on the Black wire from the Adapter box to Pin 3
6. Connect the second wire in the cable from the 8710 to either Pin 1 or Pin2.

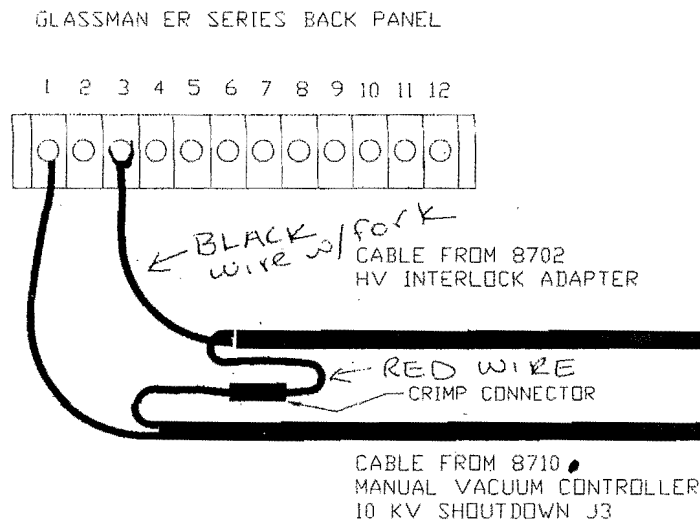

EW Series Extended Current* 500 Watt Regulated High Voltage DC Power Supplies

Up To 60 kV... 3.5 Inch Panel Height

Laboratory Performance

Enhanced Features

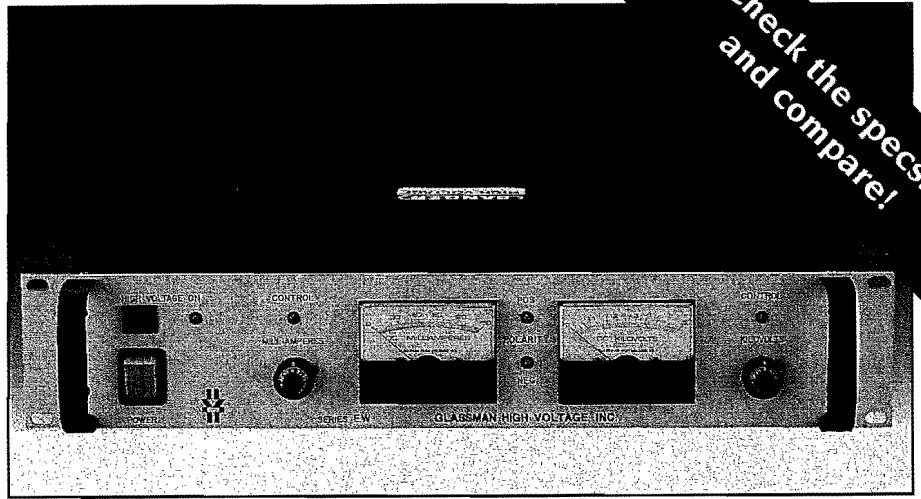

Models from 0 to 1 kV through 0 to 60 kV

The EW Series is a 500 watt regulated high voltage DC power supply with an important difference . . . maximum current ratings are equivalent to a 600 W supply! This maximum current, which is available for all output voltages up to 84% of rated voltage, should be of significant interest for many applications. The EW is offered with dual analog voltage and current meters or, optionally, with dual digital meters or a blank panel for OEM/systems applications.

Features:

***Extended Current.** EW Series models have maximum current ratings that are equivalent to a 600 W supply. These currents are available up to 84% of rated output voltage. Above this point, current is linearly derated to maintain a constant 500 W maximum output.

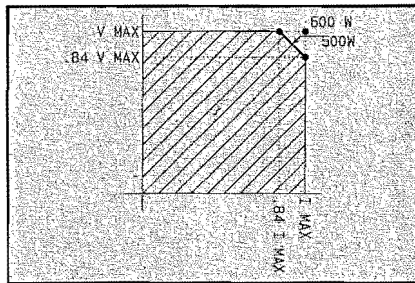

Pulse-Width Modulation. Off-the-line pulse-width modulation provides high efficiency and a reduced parts count for improved reliability.

Air Insulated. The EW Series features "air" as the primary dielectric medium. No oil or encapsulation is used to impede serviceability.

Constant Voltage/Constant Current Operation. Automatic crossover from constant-voltage to constant-current regulation provides protection against overloads, arcs, and short circuits.

Low Ripple. Ripple is less than 0.02% of rated voltage at full load.

Tight Regulation. Voltage regulation is better than 0.005% for allowable line and load variations. Current regulation is better than 0.05% from short circuit to rated voltage.

Front Panel Controls (Analog and Digital Versions.) Separate 10-turn controls with locking vernier dials are used to set voltage and current levels. A high voltage enable switch and an AC power on/off switch complete the panel controls. Annunciators indicate when high voltage is on, the output polarity, and whether the supply is operating in a voltage or current regulating mode. For the blank panel version, only a power on/off switch is provided on the panel.

Remote Control Facilities. As standard, all EW Series supplies provide output voltage and current program/monitor terminals, TTL high voltage enable/disable, safety interlock terminals, and a +10 volt reference source.

Small Size and Weight. EW Series power supplies occupy only 3.5 inches of panel height. Net weight is less than 18 pounds.

Innovations in high voltage power supply technology.



GLASSMAN HIGH VOLTAGE INC.

Route 22, Salem Industrial Park, PO Box 551, Whitehouse Station, NJ 08889
(908) 534-9007 • TWX 710-480-2839 • FAX (908) 534-5672

GLASSMAN EUROPE Limited (UK)
(0256) 810808 • FAX (0256) 810815

GLASSMAN JAPAN High Voltage Limited
(044) 877-4546 • FAX (044) 877-3395

Specifications:

Input: 102-132 V RMS standard, single-phase, 48-63 Hz, <10 A. Connector per IEC 320/V1 with mating line cord, terminated with NEMA 5-15 plug.

Efficiency: Typically 85% at full load.

Output: Continuous, stable adjustment from 0 to rated voltage/current by external 0 to +10 V signal, external potentiometers, or panel-mounted 10-turn potentiometers with 0.05% resolution. Accuracy, 1% rated + 1% setting. Repeatability better than 0.1% fs.

Stored Energy: <1.5 Joules, 20 kV; <4 Joules, 60 kV.

Voltage Regulation: Better than 0.005% for specified line variations and 0.005% + 1 mV/mA for load variations.

Ripple: <0.02% of rated voltage + 0.5 V RMS at full load.

Current Regulation: Better than 0.05% from short circuit to rated voltage at any load condition.

Voltage Monitor: 0 to +10 V equivalent to 0 to rated voltage. Accuracy, 1% reading + 1% rated.

Current Monitor: 0 to +10 V equivalent to 0 to rated current. Accuracy, 1% reading + 0.05% rated for single polarity, 1% reading + 0.1% rated for reversible polarity.

Stability: 0.01% per hour after 1/2 hour warmup, 0.05% per 8 hours.

Voltage Rise/Decay Time Constant: 50 ms typical with a 30% resistive load using either TTL on/off or remote programming control.

Temperature Coefficient: 0.01% per degree C.

Ambient Temperature: -20 to +40 degree C, operating; -40 to +85 degree C, storage.

Polarity: Available with either positive, negative, or reversible polarity with respect to chassis ground.

Protection: Automatic current regulation protects against all overloads, including arcs and shorts. Fuses, surge-limiting resistors, and low energy components provide ultimate protection.

Remote Controls: Terminal block is provided for all remote functions, including common, +10 V reference, interlock, voltage and current program/monitor, TTL, ground, and local control.

External Interlock: Open off, closed on. Normally latching except for blank panel version where it is non-latching.

TTL Enable/Disable: 0-2.5 V off, 5-15 V on.

Options:

Symbol	Description
100	90-116 V input, 48-63 Hz. NEMA 5-15 plug.
200	180-232 V input, 48-63 Hz. NEMA 6-15 plug.
220	200-264 V input, 48-63 Hz. NEMA 6-15 plug.
400	48-420 Hz input.
DM	3-1/2 digit LCD panel meters.
NC	Blank front panel, power switch only.
CT	Current trip. Power supply trips off under overload condition. This option has a rear panel switch that selects either "trip" operation or normal current limiting of an overload.
ZR	Zero start interlock. Voltage control, local or remote, must be at zero before accepting an enable signal.
SS	Slow start ramp. Specify standard times of 1, 2, 3, 5, 10, 15, 20, or 30 s +/- 20%
5VC	0-5 V voltage and current program/monitor.

Models:

Positive Polarity	Negative Polarity	Reversible Polarity	Output Voltage (kV)	Output Current (mA)	Output Cable	Panel Height (in)	
Reversible only			EW1R600	0-1	0-600	RG-59	3.5
			EW15R400	0-1.5	0-400	RG-59	3.5
			EW2R300	0-2	0-300	RG-59	3.5
			EW3R200	0-3	0-200	RG-59	3.5
			EW5R120	0-5	0-120	RG-59	3.5
EW7P85	EW7N85	EW7R85	0-7	0-85	RG-8U	3.5	
EW10P60	EW10N60	EW10R60	0-10	0-60	RG-8U	3.5	
EW15P40	EW15N40	EW15R40	0-15	0-40	RG-8U	3.5	
EW20P30	EW20N30	EW20R30	0-20	0-30	RG-8U	3.5	
EW25P24	EW25N24	EW25R24	0-25	0-24	RG-8U	3.5	
EW30P20	EW30N20	EW30R20	0-30	0-20	RG-8U	3.5	
EW40P15	EW40N15	EW40R15	0-40	0-15	RG-8U	3.5	
EW50P12	EW50N12	EW50R12	0-50	0-12	RG-8U	3.5	
EW60P10	EW60N10	EW60R10	0-60	0-10	RG-8U	3.5	

Note: Product of voltage and current automatically limited to 500 W maximum.

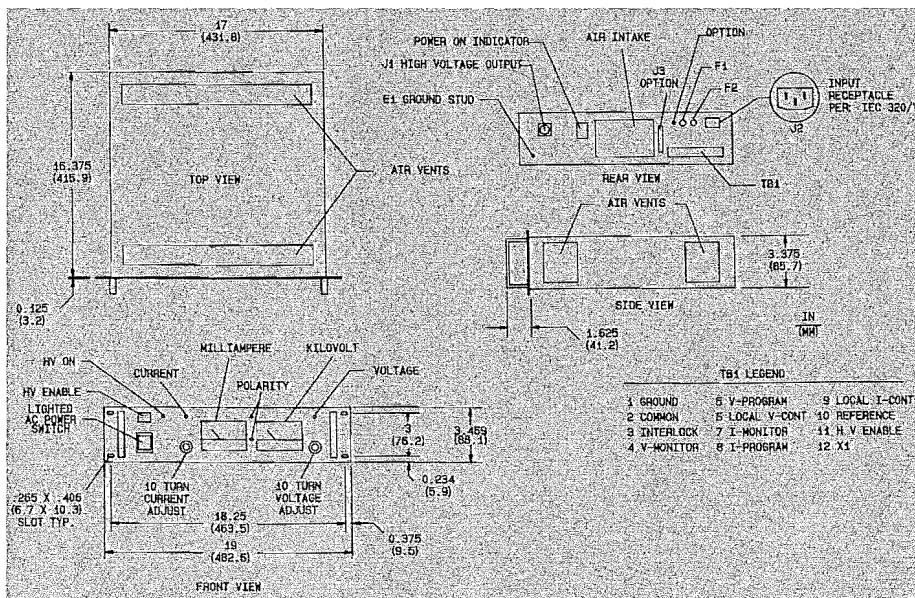

Warranty

Glassman High Voltage, Inc. warrants standard power supplies to be free from defects in materials and workmanship for three years from date of shipment. OEM and modified standard power supplies are warranted for one year from the date of shipment. The Company agrees to replace or repair any power supply that fails to perform as specified within the warranty period. Formal warranty available.



Innovations in high voltage power supply technology.

GLASSMAN HIGH VOLTAGE INC.

Route 22, Salem Industrial Park, PO Box 551, Whitehouse Station, NJ 08889
(908) 534-9007 • TWX 710-480-2839 • FAX (908) 534-5672

GLASSMAN EUROPE Limited (UK)
(0256) 810808 • FAX (0256) 810815

GLASSMAN JAPAN High Voltage Limited
(044) 877-4546 • FAX (044) 877-3395

SECTION II - GENERAL INFORMATION

UNPACKING AND INSPECTION

First inspect package exterior for evidence of rough handling in transit. If none, proceed to unpack....carefully. After removing the supply from its shipping container, inspect it thoroughly for damage.

IMPORTANT! In cases of damage due to rough handling in transit, notify the carrier immediately if damage is evident from appearance of package. Do not destroy or remove any of the packing material used in a damaged shipment. Carrier companies will usually not accept claims for damaged material unless they can inspect the damaged item and its associated packing material. Claims must be made promptly - certainly within five days of receipt of shipment.

CORRESPONDENCE

Each Glassman power supply has an identification label on the chassis that bears its model and serial number. When requesting engineering or applications information, reference should be made to this model and serial number. If specific components or circuit sections are involved in the inquiry, also indicate the component symbol number(s) shown on the applicable schematic diagram.

GLASSMAN HIGH VOLTAGE, INC.

Route 22 East
Salem Industrial Park
Whitehouse Station, N.J. 08889

TEL. 908-534-9007

FAX. 908-534-5672



CONNECTIONS AND CONTROLS

REAR PANEL ELEMENTS

J2 **AC POWER INPUT**

WARNING! The ground (center) terminal of this input should be connected to the AC outlet ground or other good earth ground.

J2 is a standard IEC receptacle. A mating line cord is provided with a plug for a standard NEMA 5-15 (NEMA 6-15 for OPTION "200" & "220") North American grounded outlet. In other regions, the appropriate plug or IEC cord set should be substituted. If the plug is removed from the cord provided, the wires should be connected as follows:

Green/Yellow - Ground

Brown - Line

Blue - Line or Neutral

Check to see that your input line voltage matches the rating of the supply before applying power (see Figures 8 and 9).

POWER ON INDICATOR

WARNING! When this lamp is illuminated, AC power is present. Do not apply or remove any connections to this unit until AC power is removed and the DC output has discharged.

J1 **HIGH VOLTAGE OUTPUT**

WARNING! Do not insert or remove the output cable from this connector until AC power is off and the DC output has discharged.



CONNECTIONS AND CONTROLS

REAR PANEL ELEMENTS

J2 **AC POWER INPUT**

WARNING! The ground (center) terminal of this input should be connected to the AC outlet ground or other good earth ground.

J2 is a standard IEC receptacle. A mating line cord is provided with a plug for a standard NEMA 5-15 (NEMA 6-15 for OPTION "200" & "220") North American grounded outlet. In other regions, the appropriate plug or IEC cord set should be substituted. If the plug is removed from the cord provided, the wires should be connected as follows:

Green/Yellow - Ground

Brown - Line

Blue - Line or Neutral

Check to see that your input line voltage matches the rating of the supply before applying power (see Figures 8 and 9).

POWER ON INDICATOR

WARNING! When this lamp is illuminated, AC power is present. Do not apply or remove any connections to this unit until AC power is removed and the DC output has discharged.

J1 **HIGH VOLTAGE OUTPUT**

WARNING! Do not insert or remove the output cable from this connector until AC power is off and the DC output has discharged.



This is the high voltage output of the supply (see figures 8 and 9). Engage the connector as follows:

UNITS > 5kV: Insert the high voltage cable provided into the receptacle. Screw the threaded barrel onto the receptacle.

UNITS ≤ 5kV: Align plug, push in, and rotate 1/2 turn to engage.

E1 GROUND STUD

WARNING! Do not operate unit without good external earth ground connected to this point.

This is the main grounding terminal for the supply (see Figures 8 and 9).

TB1 REMOTE CONTROL CONNECTOR

WARNING! Do not make or remove connections to this connector or any other connector until power is off and the output has discharged.

This connector provides inputs and outputs for the remote control functions. For a description of each of these signals and their application see Figures 1-9 and the remote control interface section.

FRONT PANEL ELEMENTS

POWER Switch/Indicator

Applies AC power to the unit when in the on ("1") position (as long as power is present at J2). The integral lamp will illuminate when power is present.

WARNING! Do not apply or remove any connections to this unit when power is on.

"NC" OPTION USERS: The front panel elements that follow, are not present on "NC" option supplies.



HIGH VOLTAGE ON Pushbutton

Enables the high voltage output when depressed. This switch will not activate the high voltage if the interlock is open.

HIGH VOLTAGE ON Indicator

Illuminates after the HV ENABLE pushbutton is depressed (if the INTERLOCK signal is closed). If this indicator is on and the HV ENABLE signal is present, the supply will generate high voltage. If the INTERLOCK signal is opened, even temporarily, the high voltage will be disabled and the HIGH VOLTAGE ON indicator will extinguish. Once the interlock is closed, the HIGH VOLTAGE ON pushbutton must again be depressed to restart the supply.

Local KILOVOLTS & MILLIAMPERES CONTROL

10-turn controls provide a 0-10V signal for local MILLIAMPERE and KILOVOLT programming. Clockwise rotation increases output. A 10- turn dial with brake is provided to secure the settings, if desired.

KILOVOLT & MILLIAMPERE CONTROL Indicators

These indicators are located above their respective controls. If the KILOVOLTS CONTROL indicator is lit, the supply is operating as a constant voltage supply with an output voltage determined by the local KILOVOLTS CONTROL or remote V-PROGRAM signal. If the MILLIAMPERES CONTROL lamp is illuminated it means one of the following:

1. The supply is operating as a constant current supply with the output current determined by the local MILLIAMPERES CONTROL or remote I-PROGRAM signal.
2. The supply is limiting its' output power to 500 watts. Reduce MILLIAMPERE or KILOVOLTS CONTROL or remote program signals so that the output is less than 500 watts.



Output Meters

Analog meters display output voltage and current with an accuracy of +/- 2% (Note: Meters operational only when power is applied to the unit. See **WARNING!** statement below.)

DM OPTION USERS: 3-1/2 digit digital panel meters are provided in place of the analog meters.

WARNING! When system is powered down under light or no load conditions, the output may retain a charge even after power is removed. This charge may not show on the kilovoltmeter. Discharge the output to ground or use an external meter to determine if output has discharged. Or, wait at least 15 seconds before making or removing any connections to the supply.

POLARITY Indicators

Indicates the output polarity of the supply with respect to ground.

INSTALLATION AND OPERATION

WARNING!

NEVER ATTEMPT TO OPERATE THIS UNIT WITHOUT A GOOD EARTH GROUND CONNECTED TO THE GROUND STUD, "E1", ON THE REAR PANEL. THE GROUND WIRE OF THE AC LINE CORD MUST ALSO BE GROUNDED.

READ AND FULLY UNDERSTAND THE OPERATING INSTRUCTIONS BEFORE APPLYING POWER TO THIS UNIT.

THIS EQUIPMENT EMPLOYS VOLTAGES THAT ARE DANGEROUS. EXTREME CAUTION MUST BE EXERCISED WHEN WORKING WITH THIS EQUIPMENT.

DO NOT HANDLE THE LOAD OR EXPOSED HIGH VOLTAGE TERMINATIONS OR ATTEMPT TO MAKE OR REMOVE ANY CONNEC-



TIONS TO THE SUPPLY UNTIL THE LOAD AND/OR SUPPLY HAS BEEN DISCHARGED (GROUNDED). AN UNLOADED SUPPLY MAY TAKE UP TO 15 SECONDS TO FULLY DISCHARGE.

ALWAYS MAKE CERTAIN THAT THE RETURN SIDE OF THE LOAD IS CONNECTED TO COMMON OR GROUND.

INITIAL TURN ON

The following procedure, to connect and operate this equipment, should be carried out only after the unit has been placed or mounted in position.

1. Check the input voltage rating on the rear panel nameplate of the power supply and make certain that this is the rating of the available power source.
2. Check to see that the POWER switch is in the off ("0") position.
3. Check to see that the jumpers are present on TB1 and are connected for local operation (see Figure 9).

USERS WITH "NC" OPTION SUPPLIES: Connect external pot or control signal to V- PROGRAM terminal.

4. Connect the high voltage output cable and ground the return lead of the load as shown in Figures 7. Connect the high voltage cable to the receptacle on the rear panel.

"NC" OPTION USERS: Connect an external kilovoltmeter to the high voltage output or monitor the V-MONITOR terminal with a DVM (0 - 10VDC = 0 - rated kV output).

5. Connect the AC input cable provided to J2 and to the power source.
6. Rotate KILOVOLTS CONTROL to the fully counterclockwise position



(set external pot or control signal on "NC" option units for zero volts programming). This is optional, but desirable so as to prevent damage to external equipment caused by inadvertent overvoltage setting. Not required if correct setting has already been established.

"NC" OPTION USERS: skip step 7

7. Rotate the MILLIAMPERES CONTROL clockwise to a level that is greater than the amount that the connected load will require (any setting above zero if no load is connected).
8. Apply input power to the supply by setting POWER switch to the on ("1") position.

"NC" OPTION USERS: Skip step 9

9. Depress HIGH VOLTAGE ON pushbutton. The HIGH VOLTAGE ON indicator should illuminate.
10. Rotate KILOVOLT CONTROL (or increase external V-PROGRAM signal) until kilovoltmeter indicates desired output voltage.
11. To shut down supply, set POWER SWITCH to the off ("0") position.

WARNING:

DO NOT HANDLE THE LOAD OR EXPOSED HIGH VOLTAGE TERMINATIONS OR ATTEMPT TO MAKE OR REMOVE ANY CONNECTIONS TO THE SUPPLY UNTIL THE LOAD AND/OR SUPPLY HAS BEEN DISCHARGED (GROUNDED). AN UNLOADED SUPPLY MAY TAKE UP TO 15 SECONDS TO FULLY DISCHARGE.



POLARITY REVERSAL - MODELS > 5kV

For reversible polarity models, the power supply has been shipped with two high voltage assemblies, one positive and one negative. One module is mounted in the chassis, the other one is shipped separately. A label on each high voltage assembly indicates its polarity. To reverse the polarity of the power supply, it is necessary to interchange the high voltage modules.

1. Remove the top cover from the unit. **BE SURE AC POWER IS DISCONNECTED AND HV IS DISCHARGED!**
2. Remove the electrical connector A2-P1 and the push lugs A2-E7 & A2-E1 which are connected to the high voltage assembly presently installed. Disconnect the two high voltage wires connected to A1-JHV1 on the main board A1 (APD-EW).

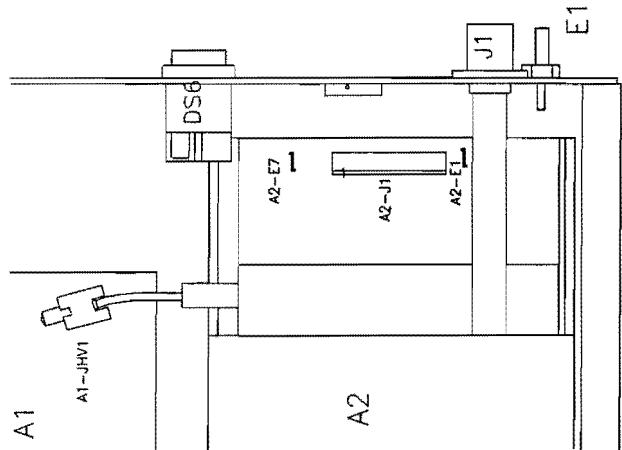

3. Tip the unit on its side to expose the four countersunk screws used to mount the high voltage module to the chassis basepan. Remove these screws, interchange the two high voltage modules and reinstall the screws.
4. Reconnect A2-P2, A2-E7, A2-E1 to the high voltage module and connect the high voltage wires to JHV1 of A1.

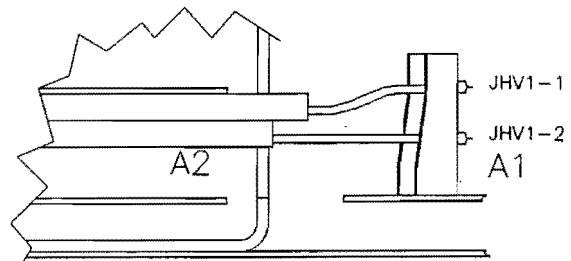

Warning! For continued safety A2-E7 & A2-E1 must be reinstalled!

5. Replace the top cover.



POLARITY REVERSAL - MODELS 5KV OR LESS

A polarity card has been provided, internal to the unit, to reverse the output polarity of the supply. If it is desired to determine the present setting of the polarity or to change the polarity, follow this procedure:

1. Remove the top cover from the unit. **BE SURE AC POWER IS DISCONNECTED AND HV IS DISCHARGED!**
2. Locate the high voltage board on the right hand side of the chassis (as viewed from the front).
3. Locate the polarity card plugged into the high voltage board and observe that the card is labeled to indicate the installed polarity.
4. If it is desired to change the polarity of the supply, simply unplug the card, flip it over, and reinstall carefully.
5. Replace the top cover.

REMOTE CONTROL INTERFACE

TB1-1 GROUND

This is the instrumentation ground connection. This terminal should not be used as the main connection to earth ground. Use the main ground terminal, "E1", for that purpose. TB1-1 is normally connected to the adjacent COMMON terminal unless a floating common is desired (see TB1-2). If a floating common is employed, this connection (or E1) should be used as the load return (see Figure 7).

TB1-2 COMMON

This terminal is the instrumentation/measurement return. Normally, COMMON is at ground potential because of a jumper to the GROUND terminal. In this configuration, instrument returns and load return may be connected to



either COMMON or GROUND. If desired, the user may remove this jumper and allow the COMMON to "float". This may be done for isolation or for the purpose of inserting a current monitoring device.

When common is floating, it is clamped internally by a bi-directional zener diode. Thus, the inserted drop should not exceed 5.0V or erroneous readings may be obtained. In this configuration, the load return must be connected to GROUND and all instrument/ programming returns must be connected to COMMON. In addition, instrument returns to COMMON must be isolated from GROUND (see Figures 7, 8 & 9).

TB1-3 INTERLOCK

This terminal must be connected to COMMON to enable the supply. If desired, the jumper may be removed and replaced by an external switch which must be closed for the supply to operate. If the external switch is opened, the supply output will drop to zero. When the switch is again closed, the front panel HIGH VOLTAGE ON pushbutton must be depressed to re-enable the supply (except on "NC" option supplies which will re-enable immediately) (see Figure 1).

TB1-4 V-MONITOR

A 0-10V positive signal (with respect to COMMON), in direct proportion to the output voltage, is available at this terminal. An internal 10k ohm, 1%, limiting resistance protects the circuitry. Therefore, it is recommended that a digital voltmeter be used to monitor this output. It is also acceptable to use a 1mA DC full scale instrument (i.e. analog meter) for monitor purposes (see Figure 5).

TB1-5 V-PROGRAM

TB1-6 LOCAL V-CONTROL ("NC" OPTION: No Connection)

A positive 0-10V signal (with respect to COMMON) at TB1-5 will program the output voltage proportionally from zero to rated output. This input can be programmed in several ways (see Figures 3, 8 & 9):

- * A user supplied 0 - +10V signal.



- * A user supplied potentiometer (5-50k ohms, 10k nominal) can be connected between the 10V REFERENCE and COMMON, with the wiper connected to the V-PROGRAM terminal.
- * The 0 - +10V signal available at TB1-6, and adjusted by the local (front panel) KILOVOLTS CONTROL (except on "NC" option supplies).
- * The V-PROGRAM input may be jumpered to the REFERENCE voltage terminal(s) for a fixed output at the maximum voltage.

TB1-7 I-MONITOR

A 0-10V signal, positive with respect to COMMON, and in direct proportion to the output current, is available at this terminal. An internal 10k ohm, 1%, limiting resistance protects the circuitry. Therefore, it is recommended that a digital voltmeter be used to monitor this output. It is also acceptable to use a 1mA DC full scale instrument (i.e. analog meter) for monitor purposes (see Figure 6).

TB1-8 I-PROGRAM

TB1-9 LOCAL I-CONTROL ("NC" OPTION: REFERENCE)

A 0-10V positive signal (with respect to COMMON) at TB1-8 will program the output current proportionally from zero to full output. This input can be programmed in several ways (see Figures 4, 8 & 9):

- * A user supplied 0 - +10V signal.
- * A user supplied potentiometer (5-50k ohms, 10k nominal) can be connected between the 10V REFERENCE and COMMON, with the wiper connected to the I-PROGRAM terminal.
- * The 0 - +10V signal available at TB1-9, adjusted by the local (front panel) MILLIAMPERES CONTROL.

*"NC" OPTION USERS: No local control is provided;
an extra REFERENCE is provided at TB1-9.*



- * The I-PROGRAM input may be jumpered to the REFERENCE voltage terminal(s) for a fixed current limit at the maximum rated current.

TB1-10 **REFERENCE**

The output of this terminal is an ultra-stable, positive, 10V reference voltage (with respect to common) that is supplied for user programming applications. Maximum current drain from this point should be limited to 4mA.

"NC" OPTION USERS: An additional REFERENCE is available on TB1-9.

TB1-11 **HV ENABLE**

This terminal must be connected to a positive 2.5-15V source (with respect to common) to enable the supply. A 0-1.5V signal at this input will disable the supply. When no external control is required this input can be jumpered to the 10V REFERENCE terminal (see Figure 2).

TB1-12 **X1**

This terminal is reserved for special options or future expansion of features.

NOTE:

Figure 8 is just one example of the many possible interface configurations.

Figure 9 shows the minimum number of connections to completely enable the supply. In this configuration, output voltage and current are controlled by the front panel controls (except on "NC" option units which have no front panel controls). No external interlock or TTL signals are required.



ZONE	REV	DESCRIPTION	DATE	APPROVED

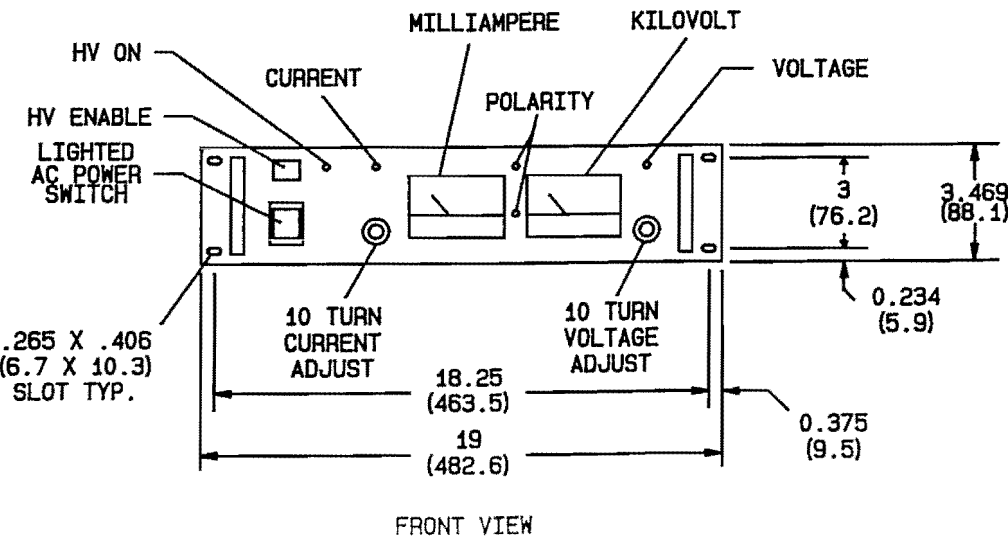
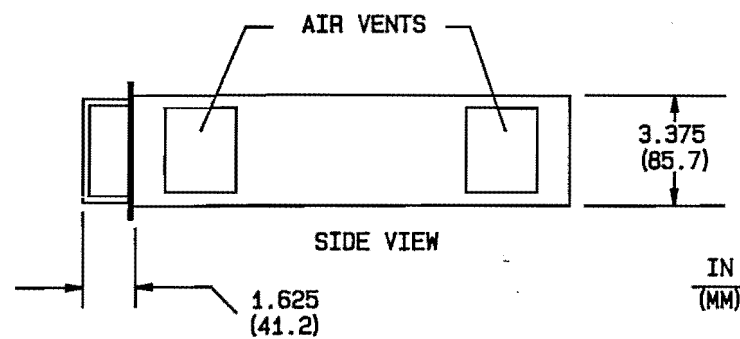
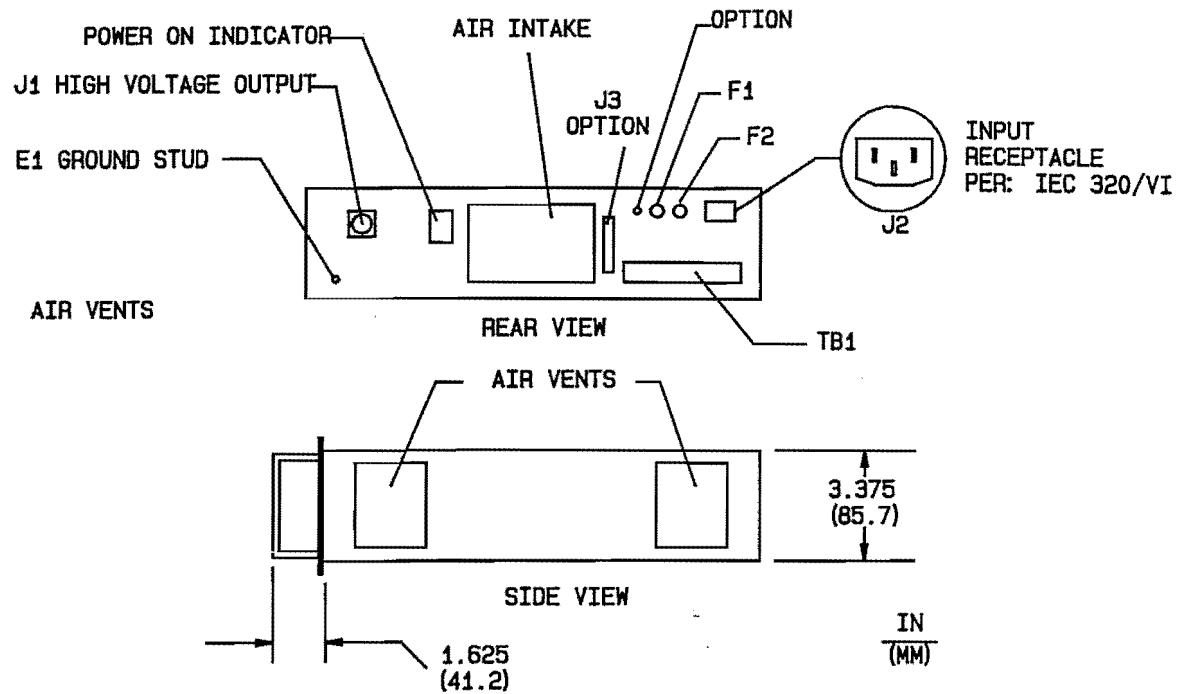
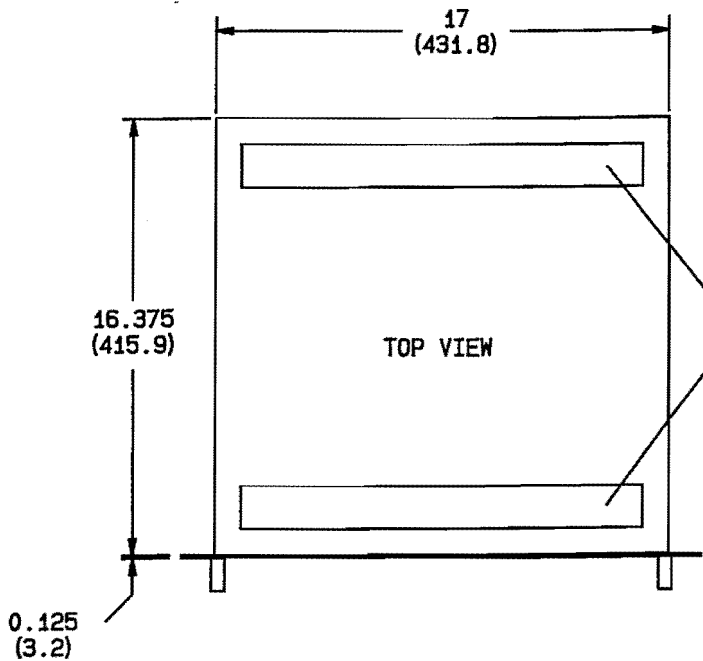

TB1 LEGEND

1 GROUND	5 V-PROGRAM	9 LOCAL I-CONT
2 COMMON	6 LOCAL V-CONT	10 REFERENCE
3 INTERLOCK	7 I-MONITOR	11 H V ENABLE
4 V-MONITOR	8 I-PROGRAM	12 X1

FILE NO.	EXTENSION	GLASSMAN HIGH VOLTAGE, INC. P.O. BOX 551, WHITEHOUSE STATION, N.J. 08889 (201) 534-9007 FAX (201) 534-5672	
2011\80002#.SCH		TITLE OUTLINE & INSTALLATION	
APPROVALS	DATE	SERIES EW	
DRAWN TA	091290	AM3-EW, ANALOG	
CHECKED JMC	101790	DWG. NO.	REV.
RELEASED		B 201180-002	NR
SCALE		SHEET 1 OF 1	

ZONE	REV	DESCRIPTION	DATE	APPROVED
	NR-1	REDRAWN	012292	DLS
	NR-2	CAD CONVERSION	072195	<i>CM</i>

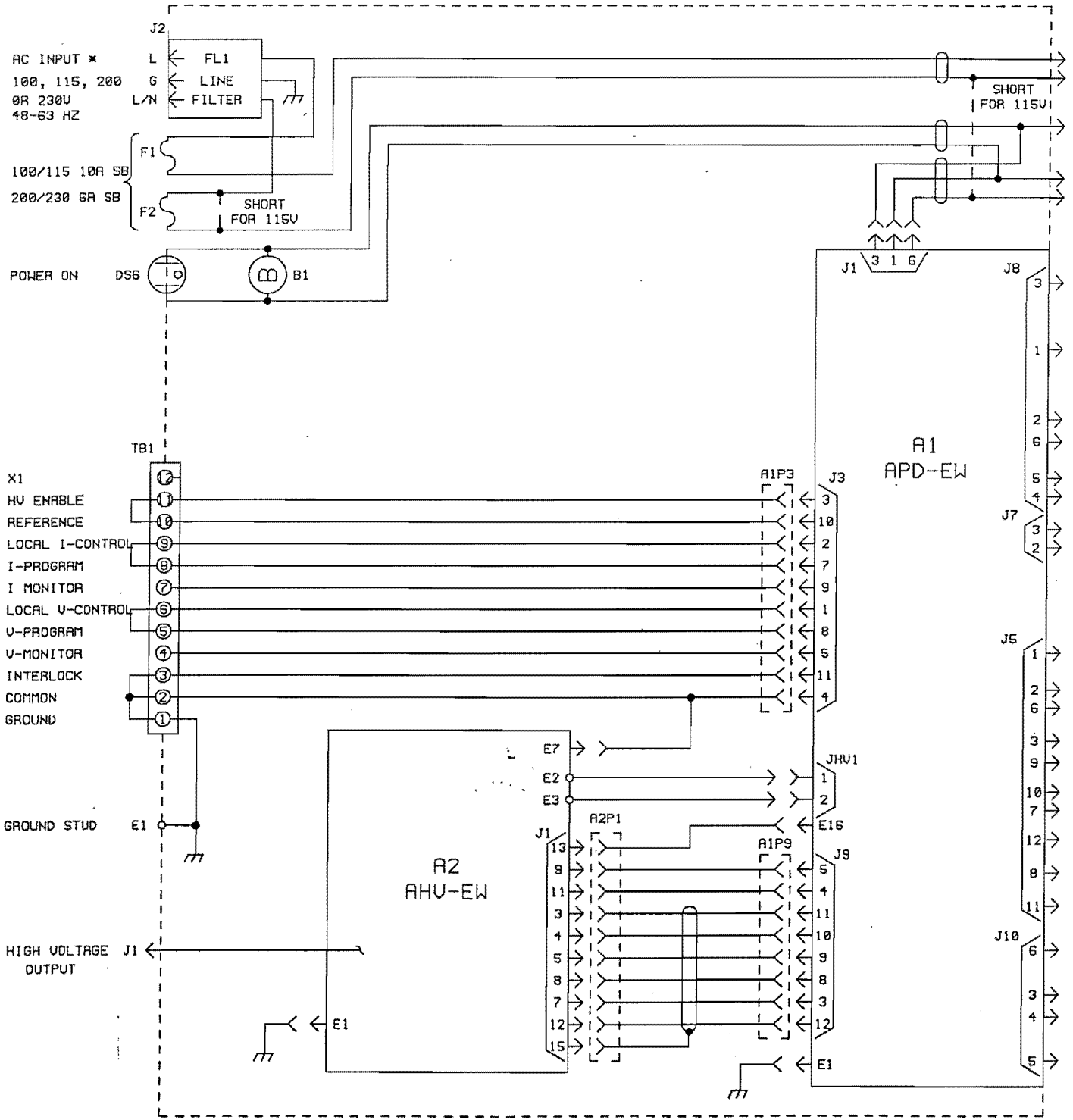

NOTES:

* REFER TO REAR PANEL LABEL FOR SPECIFIC INPUT VOLTAGE.
 G.H.V., INC. RESERVES THE RIGHT TO SUBSTITUTE PARTS WITH THOSE OF SIMILAR OR BETTER PERFORMANCE.

REDUCED ONLY

UNLESS OTHERWISE SPECIFIED DIMENSIONS ARE IN INCHES TOLERANCES ARE: DEC. XXXC XXZ	FILE NO.	EXTENSION	GLASSMAN HIGH VOLTAGE, INC.	
	\3000\06001#2.SCH		P.O. BOX 551, WHITEHOUSE STATION, N.J. 08889 (908) 534-9007 FAX (908) 534-5672	
MATERIAL	APPROVALS	DATE	TITLE	
FINISH	CHECKED J.M.	103190	SCHEMATIC MAIN ASSEMBLY AM3-EW-1	
DO NOT SCALE DRAWING	RELEASED		DWG. NO.	REV.
			C 300086-001	NR-2
			SCALE NONE	SHEET 1 OF 1

ZONE	REV	DESCRIPTION	DATE	APPROVED
NR-1		ADDED WK SERIES	112791	J.M.
NR-2		ADDED "REDUCED ONLY"	012492	DWS
NR-3		REMOVED WK SERIES	030592	DWS
NR-4		ADDED WK SERIES	063093	DWS
NR-5		CAD CONVERSION	071995	J.M.

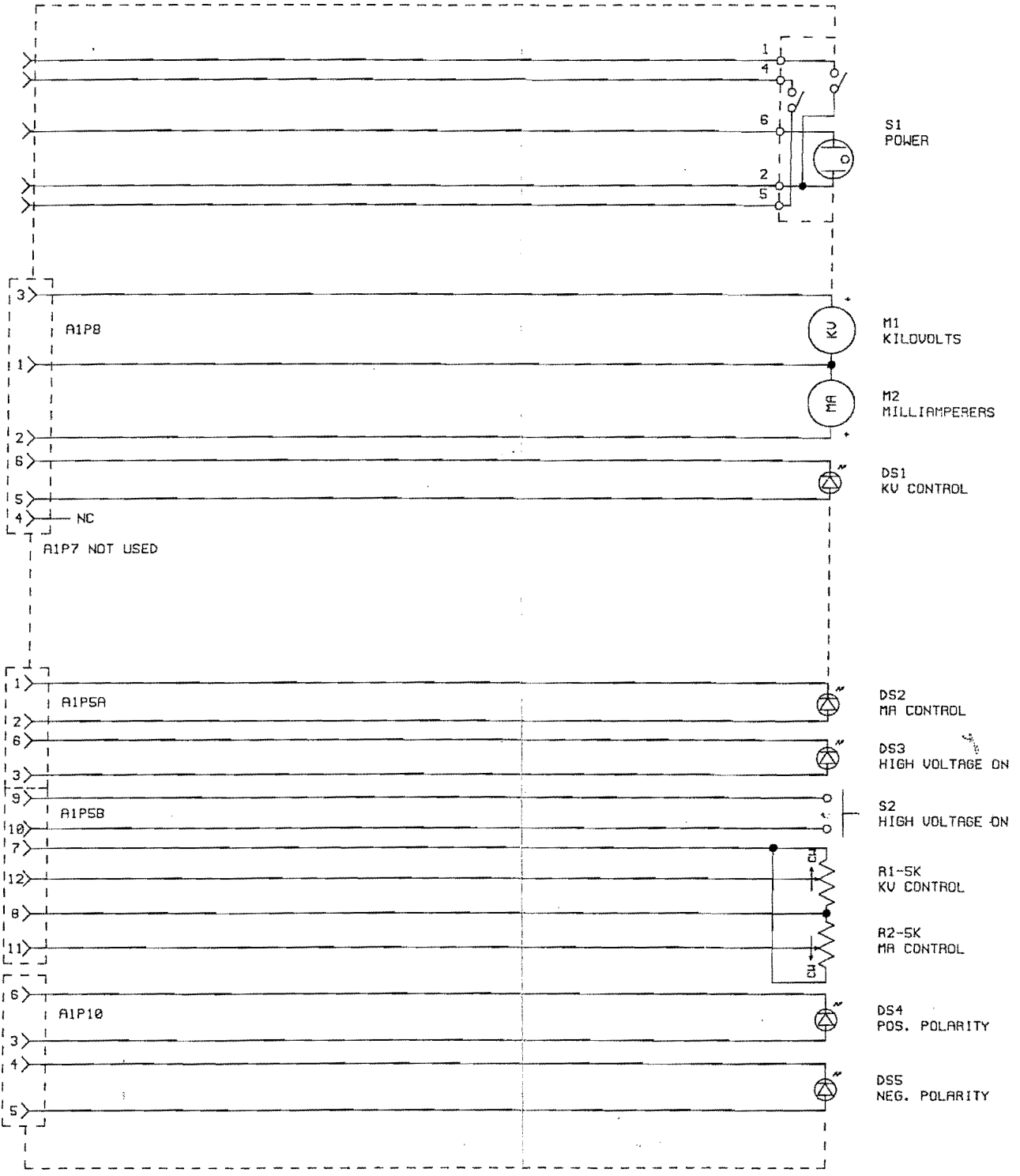

REDUCED ONLY

NOTES:

- ALL ITEMS SHOWN ARE PREFIXED BY "I".
EXAMPLE: IS1.
- G.H.V., INC. RESERVES THE RIGHT TO SUBSTITUTE PARTS WITH THOSE OF SIMILAR OR BETTER PERFORMANCE.

UNLESS OTHERWISE SPECIFIED DIMENSIONS ARE IN INCHES TOLERANCES ARE: DEC. XXX [±] XX [±] DEC. %	FILE NO.	EXTENSION	GLASSMAN HIGH VOLTAGE, INC. P.O. BOX 551, WHITEHOUSE STATION, N.J. 07093 (908) 534-9207 FAX (908) 534-5672	
	\3000\B7001#1.SCH		APPROVALS	DATE
MATERIAL	DRAWN	MES	102690	TITLE SCHEMATIC FRONT PANEL, ANALOG AFP-EW-1-A, AFP-WK-1-A
FINISH	CHECKED	J.M.	103190	DWG. NO. 300087-001
DO NOT SCALE DRAWING	RELEASED			REV. NR-5
			SCALE NONE	SHEET 1 OF 1

REMOTE INTERLOCK

FIGURE 1

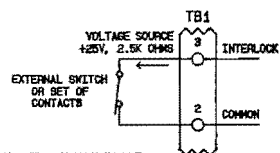

CLOSED = SUPPLY ENABLE #
OPEN = SUPPLY DISABLE
REFER TO INSTRUCTION MANUAL

REMOTE HV ENABLE

FIGURE 2

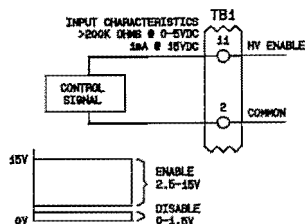

VOLTAGE MONITOR

FIGURE 5

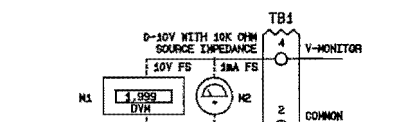

V-MONITOR OPTIONS:
M1 - RECOMMENDED TYPE METER
0 - 10VDC DIGITAL VOLTMETER
0 - 10V IS DIRECTLY PROPORTIONAL TO 0 - MAX KV RATING
M2 - ALTERNATE TYPE METER
0 - 1mA FULL SCALE CURRENT METER
0 - 1mA IS DIRECTLY PROPORTIONAL TO 0 - MAX KV RATING

CURRENT MONITOR

FIGURE 6

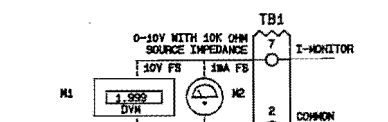

I-MONITOR OPTIONS:
M1 - RECOMMENDED TYPE METER
0 - 10VDC DIGITAL VOLTMETER
0 - 10V IS DIRECTLY PROPORTIONAL TO 0 - MAX mA RATING
M2 - ALTERNATE TYPE METER
0 - 1mA FULL SCALE CURRENT METER
0 - 1mA IS DIRECTLY PROPORTIONAL TO 0 - MAX mA RATING

VOLTAGE PROGRAMMING

FIGURE 3

VOLTAGE PROGRAM TO MAXIMUM BY CONNECTING TO REFERENCE TERMINAL OR ADJUSTABLE BY CONNECTING TO LOCAL V-CONTROL TERMINAL.

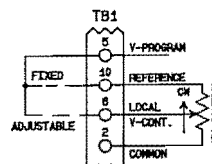

REMOTE VOLTAGE PROGRAMMED BY ATTACHING A 5K TO 50K POTENTIOMETER BETWEEN REFERENCE AND COMMON WITH THE WIPER ARM TO VOLTAGE PROGRAMMING.

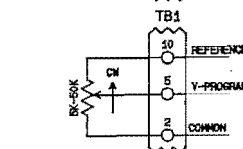

THE SUPPLY MAY BE PROGRAMMED WITH A REMOTE 0-10VDC VOLTAGE WHICH IS POSITIVE WITH RESPECT TO SYSTEM COMMON.

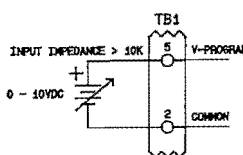

CURRENT PROGRAM

CURRENT PROGRAM TO MAXIMUM BY CONNECTING TO REFERENCE TERMINAL OR ADJUSTABLE BY CONNECTING TO LOCAL I-CONTROL TERMINAL.

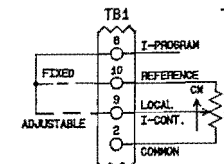

REMOTE CURRENT PROGRAMMED BY ATTACHING A 5K TO 50K POTENTIOMETER BETWEEN REFERENCE AND COMMON WITH THE WIPER ARM TO CURRENT PROGRAMMING.

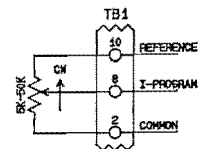

THE SUPPLY MAY BE PROGRAMMED WITH A REMOTE 0-10VDC VOLTAGE WHICH IS POSITIVE WITH RESPECT TO SYSTEM COMMON.

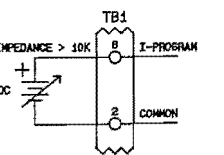

ZONE	REV	DESCRIPTION	DATE	APPROVED
HR-2		ADDED EN SERIES NOTE TO FIG 7 & FIG 8 NEW MAX .1MA @ 10VDC	12/7/70	JAC:JL
HR-2		TYPED ERROR FIG 7	04/08/71	J.L.
A		ENH 500W PIV 8	02/02/71	L.P.
B		REWORKED FIG'S 2, 5 & 6	01/26/71	J.L.
C		ECN 3044:FIG 3	02/24/71	W.C.

FIGURE 4

COMMON AND GROUND

FIGURE 7

SYSTEM COMMON AND GROUND ARE NORMALLY TERMINATED TOGETHER. IN THIS CONFIGURATION, SIGNAL RETURNS AND LOAD RETURN CAN BE CONNECTED EITHER TO GROUND OR COMMON.

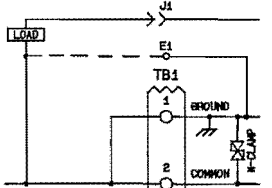

MODELS <= 5KV: CLAMP VOLTAGE = 10V
MODELS > 5KV: CLAMP VOLTAGE = 15V

TO "FLOAT" COMMON FOR ISOLATION OR MEASUREMENT PURPOSES, REMOVE COMMON AND GROUND CONNECTION ON TB1. FOR THIS CONFIGURATION INSTRUMENT RETURNS MUST BE TIED TO COMMON, AND LOAD RETURN MUST BE CONNECTED TO GROUND. INSTRUMENT RETURNS MUST BE FLOATING WITH RESPECT TO GROUND. SINCE COMMON IS INTERNALLY CLAMPED TO GROUND WITH A BIDIRECTIONAL ZENER, THE DROP ACROSS THE SHUNT SHOULD BE < 5.0 V TO MAINTAIN ACCURACY.

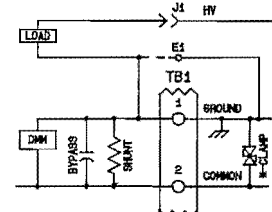

MODELS <= 5KV: CLAMP VOLTAGE = 10V
MODELS > 5KV: CLAMP VOLTAGE = 15V

A TYPICAL ER OR EW INSTALLATION *

FIGURE 8

WARNING
DO NOT OPERATE WITHOUT GOOD EXTERNAL GROUND

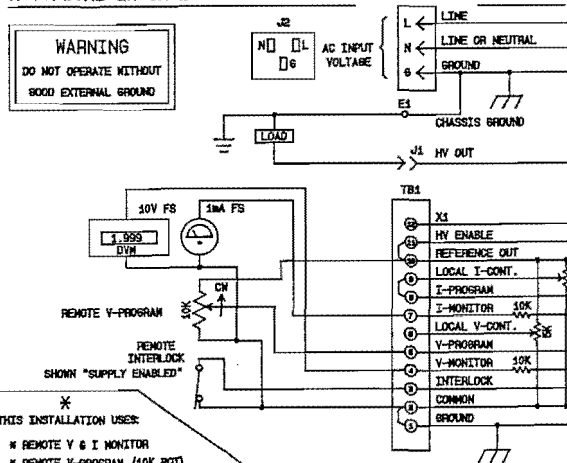

THIS INSTALLATION USES:
REMOTE V & I MONITOR
REMOTE V-PROGRAM (10K POT)
LOCAL ADJUSTABLE CURRENT PROGRAM
LOCAL HV ENABLE
REMOTE INTERLOCK CONTACT OR SWITCH
HIGH VOLTAGE RETURN GROUNDED
GROUND CONNECTED TO COMMON

NOTE:
CONNECTIONS BETWEEN ADJACENT TERMINALS ON TB1 CAN BE MADE USING THE METAL LINKS SUPPLIED.

MINIMUM NUMBER OF CONNECTIONS IN ORDER TO COMPLETELY ENABLE THE ER OR EW SUPPLY. *

FIGURE 9

WARNING
DO NOT OPERATE WITHOUT GOOD EXTERNAL GROUND

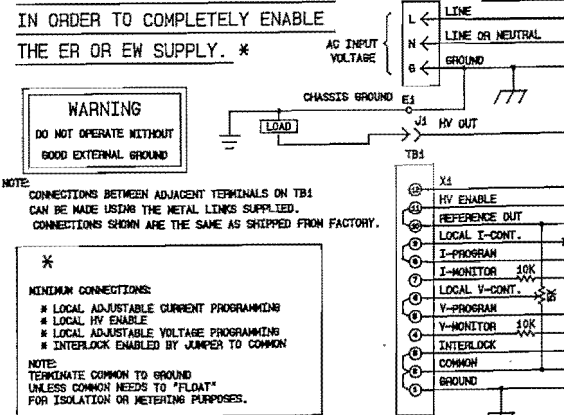

NOTE:
CONNECTIONS BETWEEN ADJACENT TERMINALS ON TB1 CAN BE MADE USING THE METAL LINKS SUPPLIED. CONNECTIONS SHOWN ARE THE SAME AS SHIPPED FROM FACTORY.

*
MINIMUM CONNECTIONS:
LOCAL ADJUSTABLE CURRENT PROGRAMMING
LOCAL HV ENABLE
LOCAL ADJUSTABLE VOLTAGE PROGRAMMING
INTERLOCK ENABLED BY JUMPER TO COMMON

NOTE:
TERMINATE COMMON TO GROUND UNLESS COMMON NEEDS TO "FLOAT" FOR ISOLATION OR MEASURING PURPOSES.

REDUCED ONLY

UNLESS OTHERWISE SPECIFIED DIMENSIONS ARE IN INCHES TOLERANCES ARE:	FILE NO.	EXTENSION	GLASSMAN HIGH VOLTAGE, INC.
DEC. .001	14000V4004C.301		P.O. BOX 661, WESTERHURST STATION, N.J. 07063 908 584-9007 FAX 908 584-9872
DR. .001	APPROVAL#	DATE	TITLE
	DRAWN JAC III	000180	INTERFACE DIAGRAM ER & EW SERIES
	CHECKED JAC III	000180	
	RELEASED		
DO NOT SCALE DRAWING			D DWG. NO. 400041-004 REV. C
			SCALE NONE SHEET 1 OF 1

ZONE	REV	DESCRIPTION	DATE	APPROVED
	NR-1	ADDED REDUCED ONLY	05/29/92	LWS

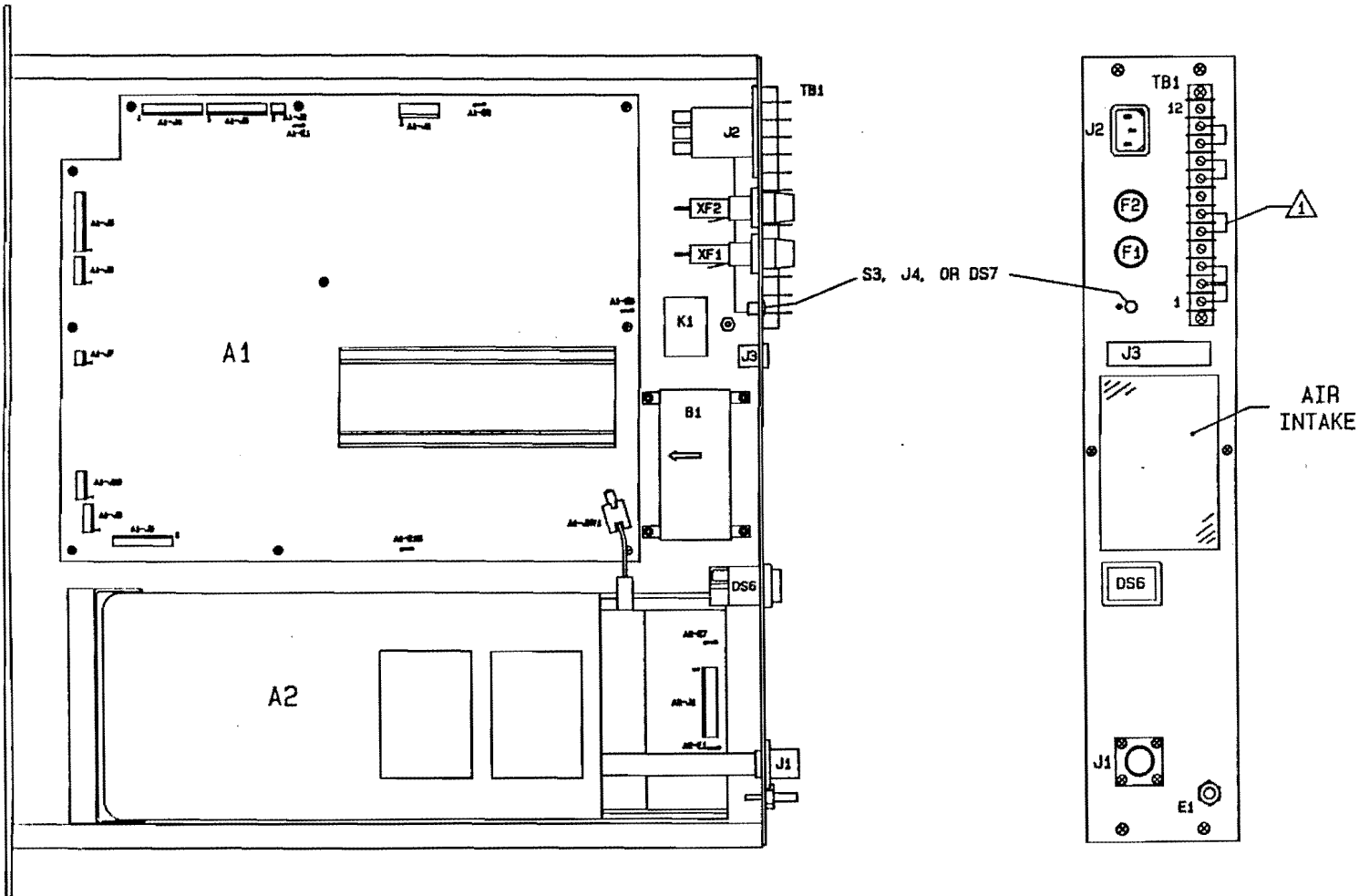

NOTE:

⚠ THIS POSITION NOT USED ON "BLANK FRONT PANEL" MODELS.

UNLESS OTHERWISE SPECIFIED DIMENSIONS ARE IN INCHES TOLERANCES ARE:		FILE NO.	EXTENSION	GLASSMAN HIGH VOLTAGE, INC.	
DEC. XX	XX	\4012\29002\1.SCH		P.O. BOX 824, METCHEN STATION, N.J. 08058	
DES. 1	1			PHONE 824-9967 FAX 824-9972	
MATERIAL	DRAWN JMK	DATE	101790	TITLE PART PLACEMENT	
FORN	CHECKED JMC	102290		SERIES EM	
	RELEASED			AND-EM-1 >=10KV	
				D	REV. NR-1
DO NOT SCALE DRAWING				SCALE	SHEET 1 OF 1

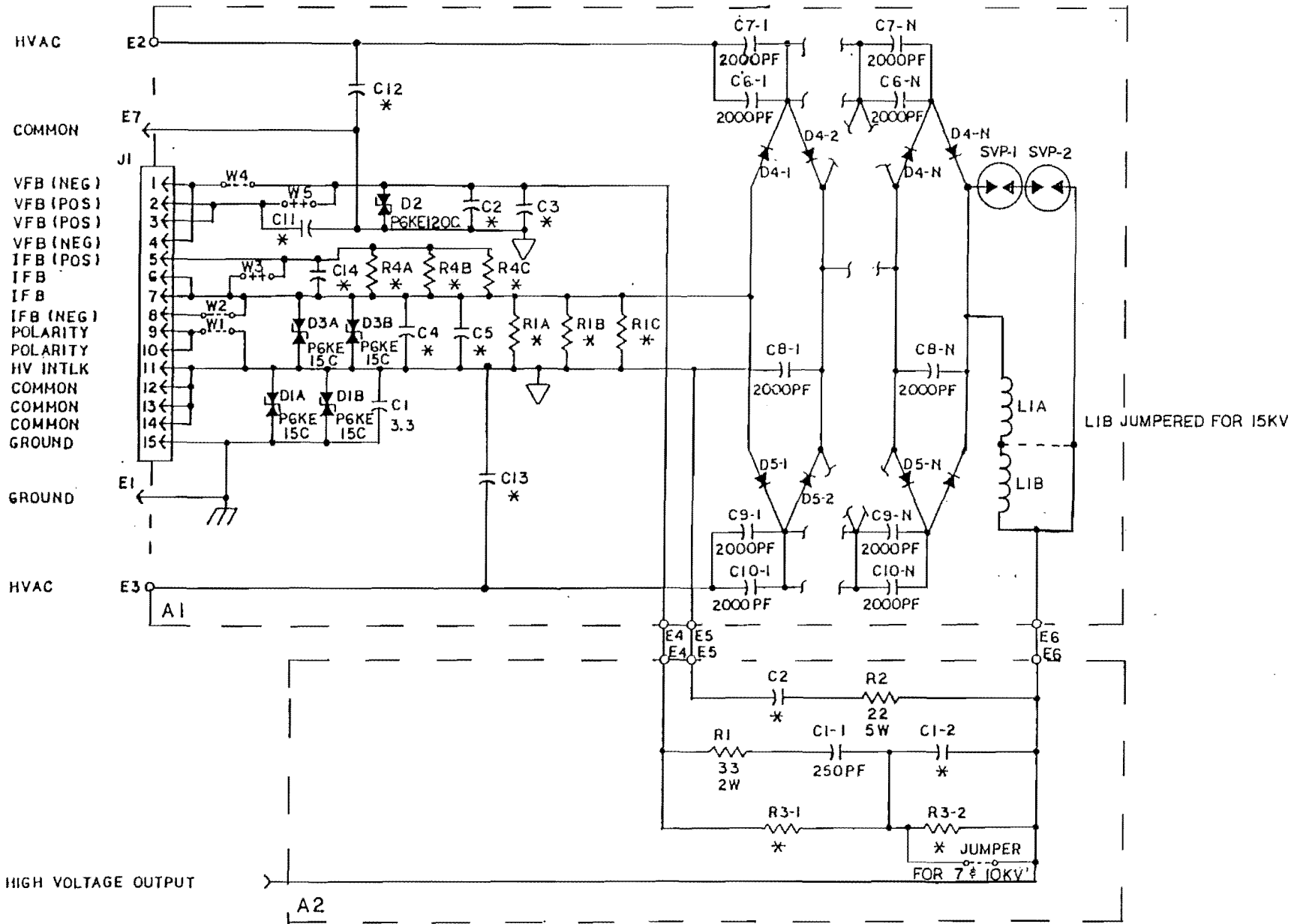

LIB JUMPERED FOR 15KV

* JUMPER FOR 7 & 10KV

NOTE

- 1 * = SELECTED PER MODEL.
- 2 D4 AND D5 SHOWN FOR POSITIVE POLARITY. REVERSE DIRECTION FOR NEGATIVE POLARITY.
- 3 G.H.V., INC. RESERVES THE RIGHT TO SUBSTITUTE PARTS FOR THOSE OF SIMILAR OR BETTER PERFORMANCE

REDUCED ONLY

REVISIONS				GLASSMAN HIGH VOLTAGE, INC.			
DESCRIPTION	CHK	DATE	LTR	TOLERANCES	SCHEMATIC		
ECH 26-38; ADD LIB & 7KV		11-27-90	A	DEC .001 ±	HIGH VOLTAGE ASSEMBLY		
				FRAC ±	AHV-EW-7KV, 10KV, 15KV		
				Drawn Date	DRAWING NO.		
				MES 11-6-90	300088-001		
				Check Date	REV. A		
				SCALE	Sheet 1 of 1		

REV	BY	DESCRIPTION	DATE	APPROVED

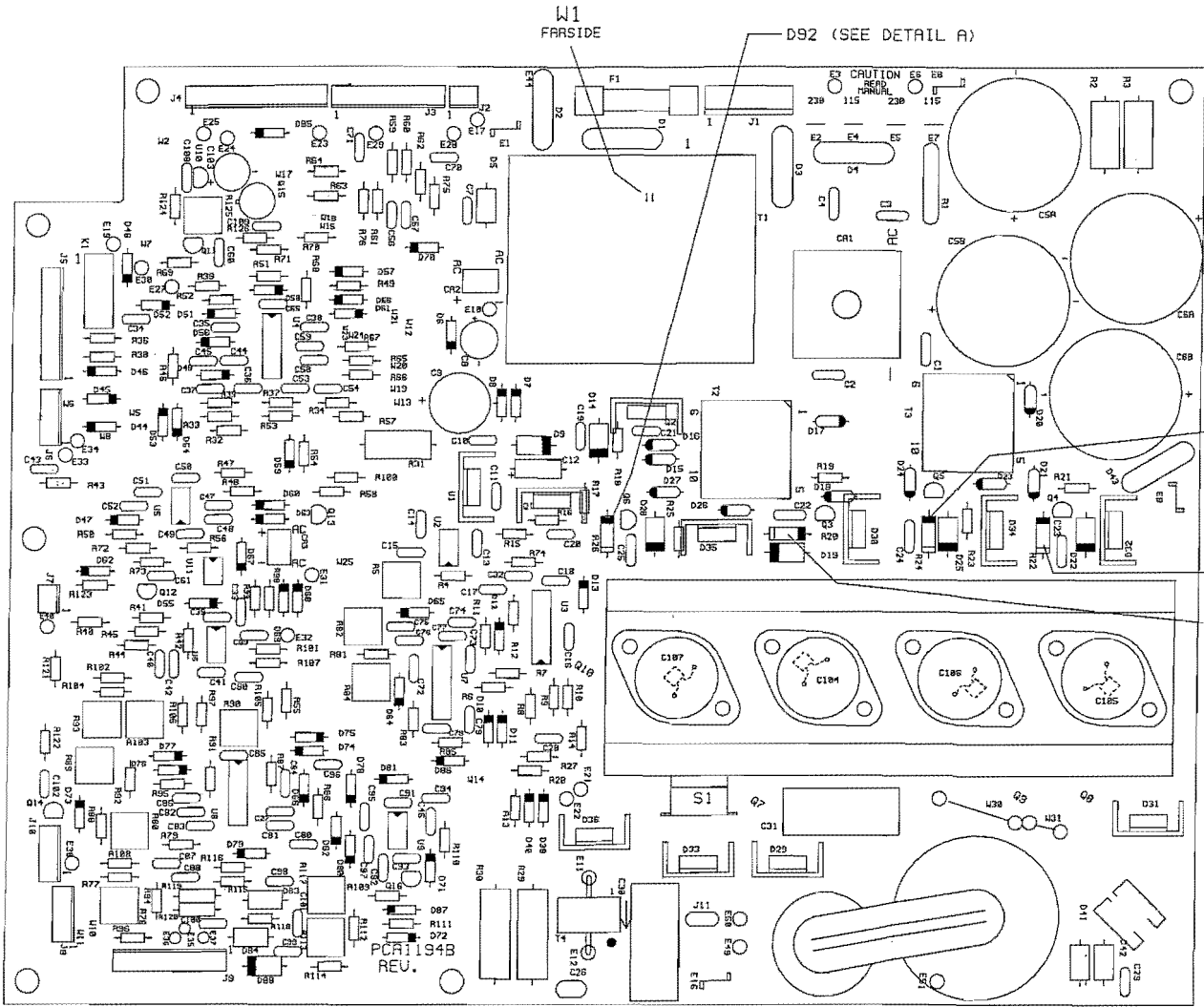

D91 (SEE DETAIL A)

D90 (SEE DETAIL A)

D89 (SEE DETAIL A)

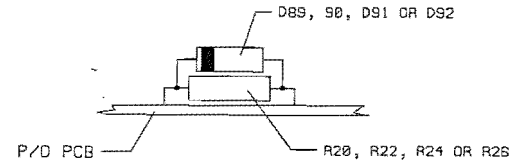

DETAIL A

REDUCED ONLY

FILE NO. EXTENSION PCA1194008#.PCB		 GLASSMAN HIGH VOLTAGE, INC. P.O. BOX 551, WHITEHOUSE STATION, N.J. 08889 (908) 534-9887 FAX (908) 534-5672	
APPROVALS	DATE	TITLE PARTS PLACEMENT APD-EW	
DRAWN JHK	110295	C DWG. NO. PCA1194-008	
CHECKED <i>fm</i>	110295	REV. NR	
RELEASED		SCALE	SHEET 1 OF 1

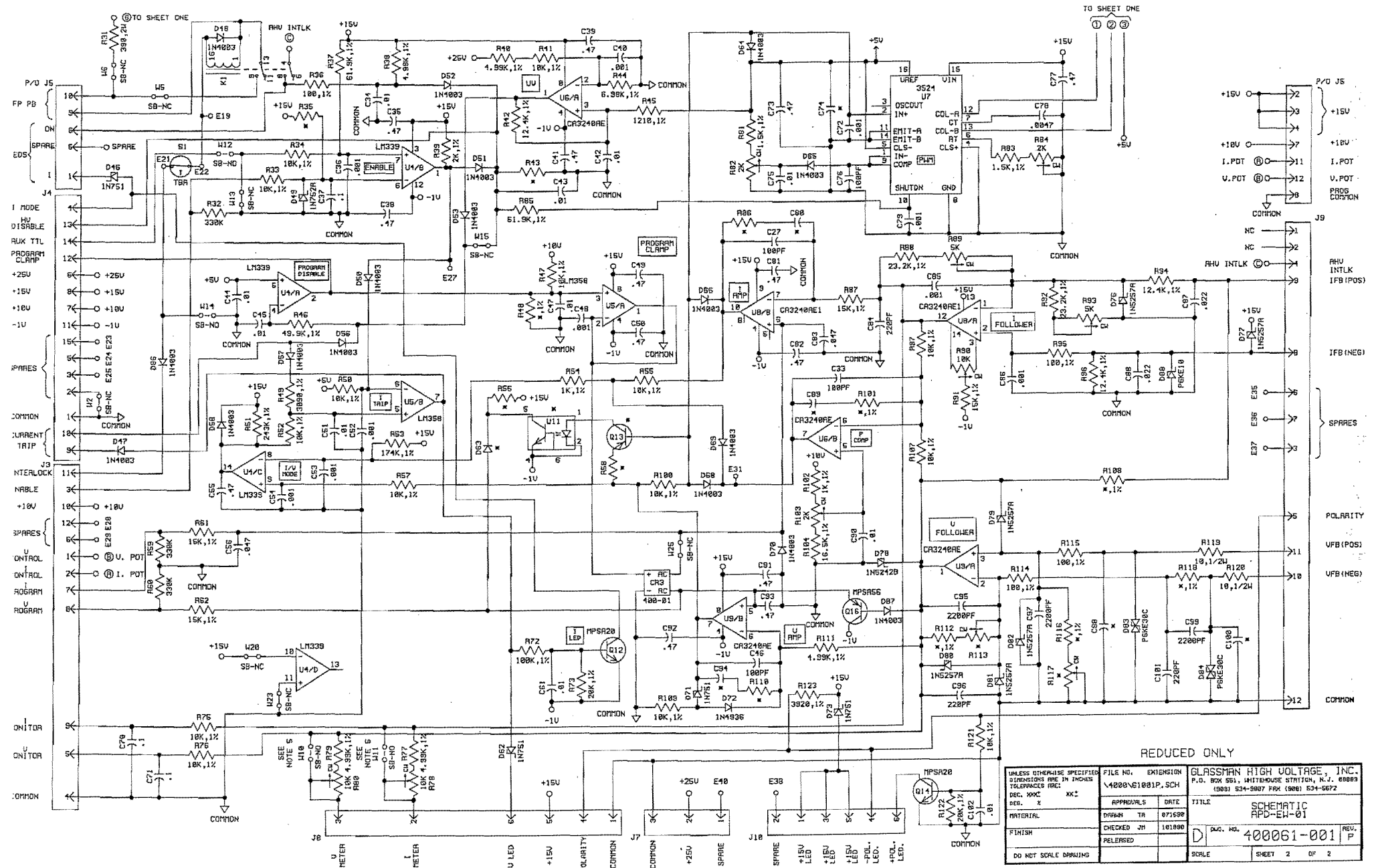

REDUCED ONLY

UNLESS OTHERWISE SPECIFIED TOLERANCES ARE IN INCHES DEC. 100C. DEC. 100C. DEC. 100C.		FILE NO. EXTENSION 4400061001P.SCH	GLASSMAN HIGH VOLTAGE, INC. P.O. BOX 551, WHITEHOUSE STATION, N.J. 08859 (908) 534-5957 FAX (908) 534-5672
MATERIAL	FINISH	APPROVALS DRAWN TR CHECKED JH RELEASED	DATE 071599 101990
TITLE SCHEMATIC APD-EW-01		Dwg. No. 400061-001	
DO NOT SCALE DRAWING		SCALE	SHEET 2 OF 2