

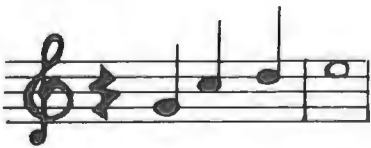

DRI-LAB TECHNICAL MANUAL HE / DL SERIES

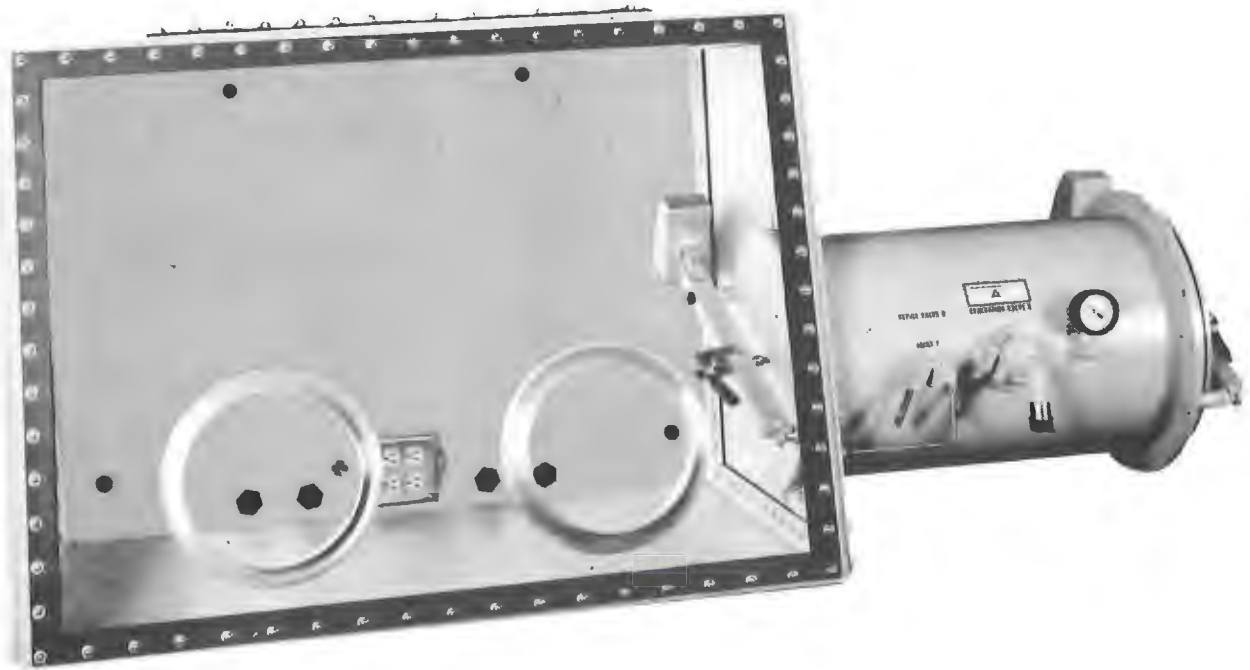

DRI-LAB-08/85

VACUUM/ATMOSPHERES COMPANY

4652 ROSECRANS AVE. • HAWTHORNE, CA 90250-6896
PHONE (213) 644-0255 • FAX (213) 970-0980

Contents

List of Figures	iv
List of Tables	iv
INTRODUCTION	v
1. OVERVIEW	1-1
Application	1-1
Functional Description	1-1
2. INSTALLATION.	2-1
General	2-1
Customer-Furnished Items	2-1
Utility Requirements	2-1
Electrical	2-1
Vacuum Line	2-2
Gas Supply	2-2
Installing the Gloves	2-2
Leak Testing	2-2
Leak In Gloves	2-5
Oxygen and Moisture Testing	2-6
Electric Lightbulb Test	2-6
Welding Chamber Test	2-6
Titanium Tetrachloride Test	2-7
Diethylzinc Test	2-7
3. OPERATIONS	3-1
General	3-1
Establishing An Inert Atmosphere	3-1
Antechamber	3-2
Evacuate/Refill Procedure	3-2
Glove Box	3-2
Passing Materials In/Out of Dri-Lab	3-3

Contents (Cont'd)

4.	MAINTENANCE AND TROUBLESHOOTING	4-1
	General	4-1
	Periodic Maintenance	4-1
	Safety Glass Panels	4-1
	Lexan Panels	4-1
	Dri-Lab	4-2
	Antechamber	4-2
	Replacing Old Gloves	4-2
	Accessories	4-4
	Troubleshooting	4-4
5.	PARTS AND ACCESSORIES	5-1
	Replacement Policy	5-1
	Spare Parts	5-1
	Accessories	5-1
 APPENDIXES		
A.	Specifications and Dimensions	A-1
B.	Special Schematics or Diagrams	B-1
	Schematic Diagram Of Junction Box	B-2
C.	Warranty	C-1
D.	Spare Part Listings	D-1
E.	Accessories	E-1
INDEX		Index-1

List of Figures

<u>Figures</u>		<u>Page</u>
1-1	Dri-Lab Assembly and Connections	1-2
2-1	Installing Gloves On Glove Box	2-3
2-2	Leak Testing Dri-Lab Without Detector	2-5
3-1	Establishing An Inert Atmosphere	3-1
3-2	Procedure For Passing Materials Into Dri-Lab .	3-4
3-3	Procedure For Passing Materials Out Of Dri-Lab .	3-5
4-1	Antechamber Door Assembly	4-3
B-2	Schematic Diagram Of Junction Box	B-2

List of Tables

<u>Table</u>		<u>Page</u>
4-1	Troubleshooting Dri-Lab	4-5
C-1	Spare Parts List (HE-series)	C-1
C-2	Spare Parts List (DL-series)	C-2

INTRODUCTION

This manual provides information necessary to install, operate, and maintain Vacuum/Atmospheres HE- and DL-series Dri-Lab glove boxes.

Additional information relative to any Vacuum/Atmospheres Company (VAC) system may be obtained from:

Vacuum/Atmospheres Company
4652 West Rosecrans Avenue
Hawthorne, CA 90250-6896
Telephone: (213) 644-0255
Facsimile: (213) 970-0980

Section 1

OVERVIEW

APPLICATION

The VAC HE-series (or DL-series*) Dri-Lab provides a working area of inert atmosphere nearly free of moisture, oxygen, and if desired, nitrogen. Any material that is sensitive to moisture, oxygen, or nitrogen may be worked with freely. The Dri-Lab is designed for use of argon gas as the principal inert gas, and also may use helium, nitrogen, or any combination of these gases.

FUNCTIONAL DESCRIPTION

The HE-series Dri-Lab consists of an hermetically sealed glove box, a side-mounted antechamber, and a full-view window (Figure 1-1). The glove box and antechamber share an entry/exit airlock door, used for passing materials in and out without disturbing the glove box atmosphere. All materials are passed in and out of the glove box on a sliding tray (located on the bottom of the antechamber). The 15-in. I.D. antechamber, with one interior and one exterior door, permits large objects to be passed into and out of the glove box.

Two 9-in. glove ports and butyl rubber gloves, mounted in the full-view window, provide easy access to all areas of the glove box. An assortment of gas, water, and electrical connections are also provided in the rear of the glove box wall. (Refer to Appendix A for Dri-Lab specifications.)

* For simplicity, this manual will address the HE- rather than the DL-series Dri-Lab. Both models are essentially the same. The HE-series has removable end panels and a skylight; the DL-series does not. The HE-series is available in aluminum or stainless steel; the DL-series is available only in stainless steel.

FIGURE 1-1
DRI-LAB ASSEMBLY AND CONNECTIONS

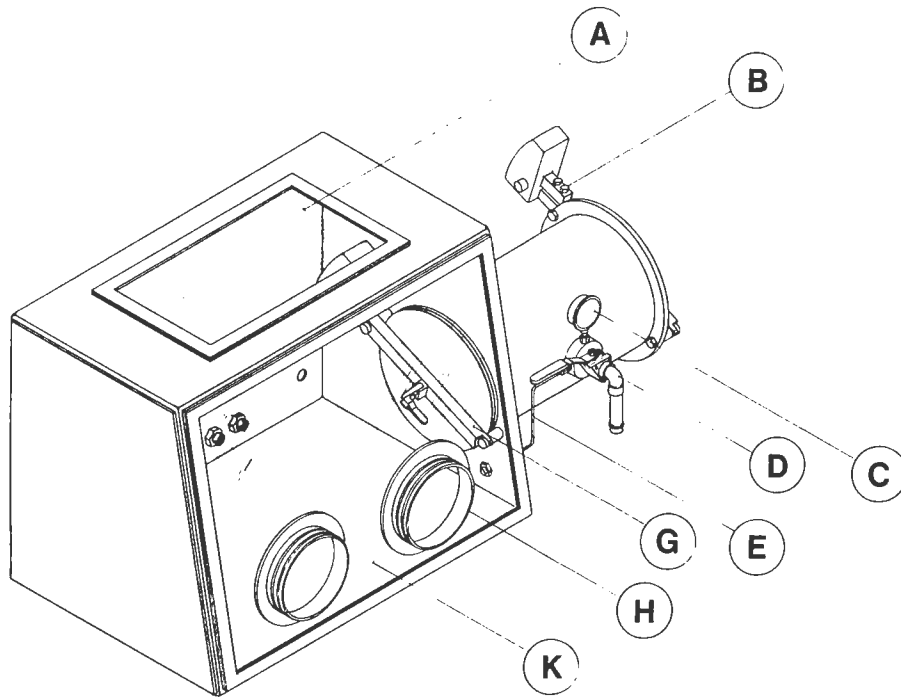

- A. SKYLIGHT LEXAN PANEL (HE SERIES ONLY).
- B. ANTECHAMBER OUTSIDE DOOR ASSEMBLY.
- C. COMPOUND GAUGE.
- D. EVACUATION VALVE AND CONNECTION TO VACUUM PUMP.
- E. ANTECHAMBER REFILL VALVE.
- G. ANTECHAMBER INSIDE DOOR ASSEMBLY.
- H. GLOVE PORT.
- K. FRONT LEXAN WINDOW.
- L. AUXILIARY FEED THROUGH PORTS.
- M. ELECTRICAL CONNECTION JUNCTION BOX.
- N. FD. THRU. PORT FOR OPTIONAL HYGROMETER.
- O. FD. THRU. PORT FOR OPTIONAL PRESSURE RELIEF.
- P. FD. THRU. PORTS FOR OPTIONAL PURIFICATION SYSTEM.

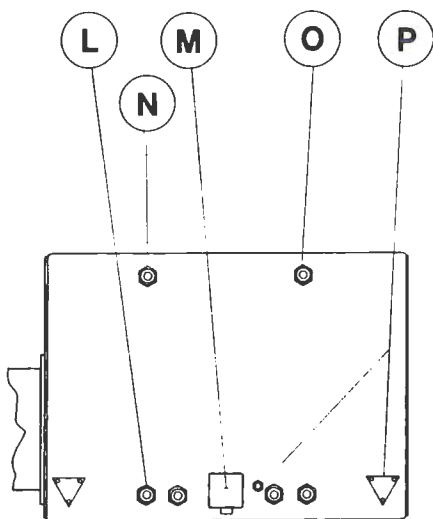

BACK VIEW

Section 2

INSTALLATION

GENERAL

Before starting the installation, read all instructions completely. Instructions are standard and some may not apply to custom systems.

- A. Remove components from crate. Do not use junction box or glove ports to lift Dri-Lab.
- B. Remove all packing, tape, and shipping blocks or bands.
- C. Place Dri-Lab stand in desired location.
- D. Place Dri-Lab on stand.
 - 1) Align side opposite antechamber flush with stand end.
 - 2) Align back side flush with stand back (single-sided Dri-Lab). Align front and back symmetrically on stand width (double-sided Dri-Lab).

CUSTOMER-FURNISHED ITEMS

Before installation is possible, the customer must furnish the following items:

- A. Vacuum pump, 3 to 5 cfm.
- B. 3/8-in. copper or stainless steel tubing for inert gas.
- C. Utilities, as noted.

UTILITY REQUIREMENTS

Electrical

- A. Skylight: 115 V, 5 A.
- B. Glove Box Junction-Box: 115 V, 15 A (see Appendix B for system schematic diagrams).
- C. Vacuum Pump: 115/230 V or as required by size and rating of vacuum pump.

Vacuum Line

Use 1-in. O.D. vacuum hose from evacuation valve on the ante-chamber to the vacuum pump (user supplied).

Gas Supply

If your Dri-Lab was not purchased with a VAC pressure control system, the gas supply should be regulated at 20 psi and connected to a main shutoff valve (user supplied) at a Dri-Lab feedthrough. VAC recommends customer use as pure a gas as economically or conveniently practical.

INSTALLING THE GLOVES

- A. Fold glove cuff inside out approximately 2 in. (Figure 2-1).
- B. Place glove into glove port/glove box and stretch cuff onto glove port flange. The bead in the cuff should be positioned in the inner groove closest to the glove box.
- C. Adjust glove so that thumb is pointed in the correct direction (up for ambidextrous, horizontal for formed L/R gloves).
- D. Stretch O-ring over glove and into the outer groove. Make sure there are no wrinkles, especially under the O-ring.
- E. Cover O-ring with black-plastic electrical tape (user supplied). Without wrinkling the glove, install the stainless steel clamp over the outer O-ring.

LEAK TESTING

Note

Prior to leak testing, if panels were removed to install equipment inside Dri-Lab, reinstall panel acorn nuts at 26 to 28 in.-lb.

FIGURE 2-1
INSTALLING GLOVES ON GLOVE BOX

- A. *GLOVE PORT RING.*
- B. *GLOVE.*
- C. *O-RING.*
- D. *BLACK PLASTIC TAPE.*
- E. *CLAMP.*

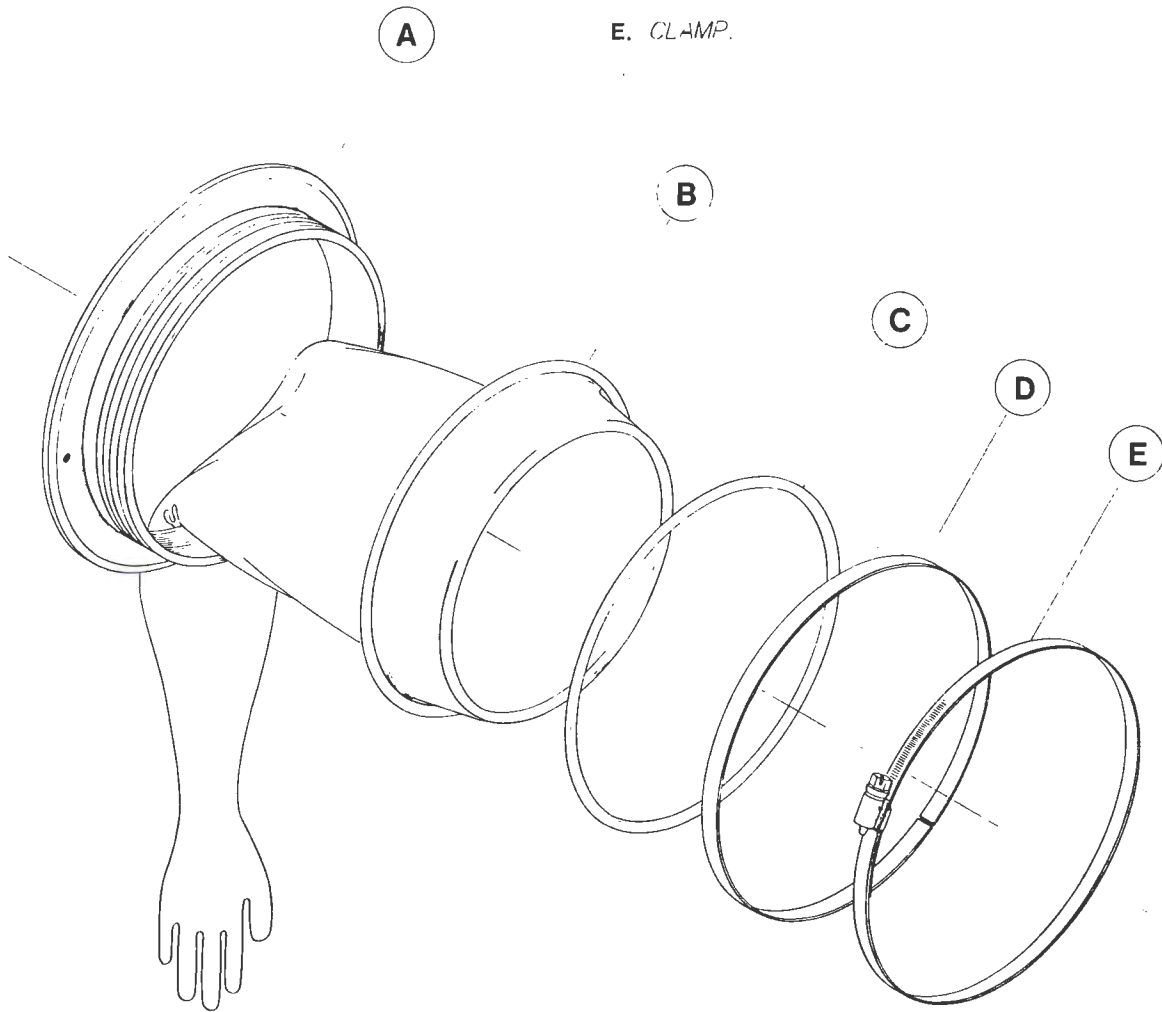

WARNING

Do not use halogen leak detection equipment for leak testing. Halogens are harmful to certain materials used in the construction of VAC equipment (i.e., copper and rubber). VAC will not assume responsibility for systems tested by methods other than defined in this manual.

VAC recommends using helium leak detection equipment. If no leak detector is available, the following test procedures are recommended (keep Dri-Lab and room temperature constant throughout testing):

- A. Connect a source of gas to one of the connections in the back of the Dri-Lab (see Figure 2-2).
- B. Close antechamber outside door; close evacuation and refill valves.
- C. Open inside antechamber door.
- D. Slowly pressurize Dri-Lab. The gloves will be forced out.
- E. Stop pressurizing when gloves are almost horizontal. (Let gloves break slightly from horizontal.)
- F. Place a stool or chair with a ruler taped on its back to within 1/4 in. of glove finger tip. Note reference point and wait approximately 1 hr.
 - o If system leaks, gloves will fall more than 1/8 in.* Locate and seal leaks. Repeat test until gloves remain steady for several hours.
 - o Relieve pressure on gloves after testing.
 - o Replace plugs removed for leak testing with teflon-taped brass plugs (user supplied).

* If a water manometer is available, connect it directly to Dri-Lab via 1/2 in. fittings in back and use manometer as a pressure indicator. Box pressure should not exceed 10-in. water column.

FIGURE 2-2
LEAK TESTING DRI-LAB WITHOUT DETECTOR

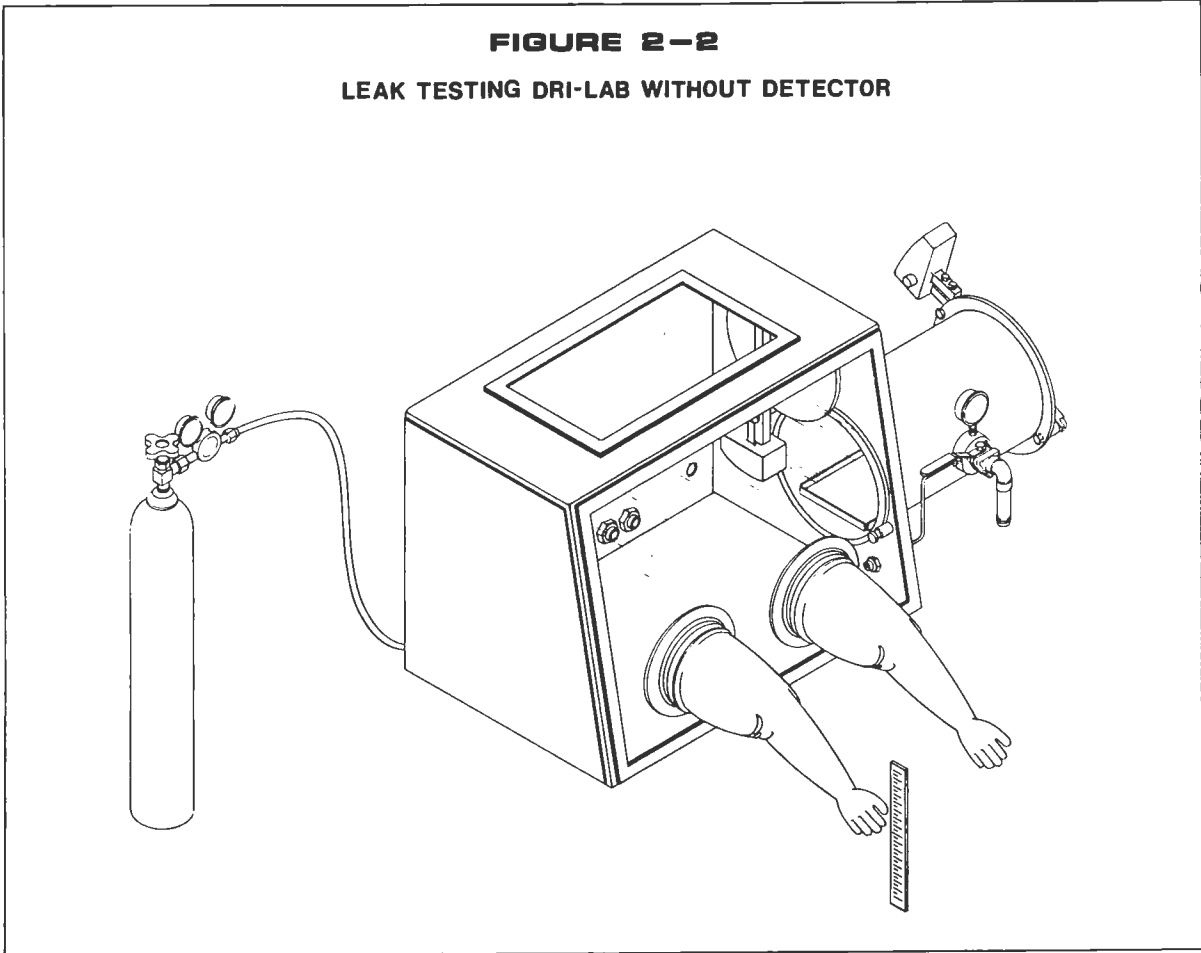

Leak in Gloves

Gloves are vulnerable to leaks, especially in the fingertips. To check for leaks:

- A. Stretch rubber to detect small holes.
- B. Check for cracks near glove port.
- C. Inflate glove, twist wrist, force into pail of water, and look for source of bubbles.

Note

Replace gloves at the first sign of deterioration. VAC recommends wearing protective gloves over Dri-Lab gloves if working processes include handling sharp, hot, or corrosive materials.

OXYGEN AND MOISTURE TESTING

WARNING

VAC does not assume responsibility for accidents resulting from mishandling of materials used in the following tests.

VAC manufactures instruments that automatically and continuously monitor Dri-Lab atmosphere for oxygen and/or moisture. In the absence of more precise instrumentation, the following tests provide a general idea of the condition of the Dri-Lab atmosphere. Note that the ppm levels stated in these tests are estimates only.

Electric Lightbulb Test

- A. File an opening or flame torch a hole through a glass 25 W lightbulb. Do not break filament.
- B. Screw bulb into a socket and pass it into the Dri-Lab. Plug into AC outlet in Dri-Lab junction box.
 - o If the filament burns out after 6 hr, the oxygen and moisture content is higher than 5 ppm.
 - o If the filament burns for days (or even weeks), the level is between 1 and 5 ppm.

Welding Chamber Test

- A. Pass a portable welder and clean sample of stainless steel into Dri-Lab.
- B. Weld a bead on the clean sample of stainless steel.
 - o If bead is clean and silver, moisture and oxygen content is between 1 and 2 ppm.
 - o If bead appears blue-black, a considerable amount of oxygen and moisture is present.

Titanium Tetrachloride Test

- A. Pass a bottle of titanium tetrachloride into Dri-Lab.
- B. Open the bottle inside the glove box, but be prepared to close the bottle immediately if you see smoke. For best results, hold a black-gloved hand behind the bottle: the white smoke will be better seen against the black background.
 - o If smoke is observed, moisture exists at a relatively high level.
 - o If no smoke is observed, the dew point is less than -60°C (10 ppm).

Diethylzinc Test**CAUTION**

Materials used in the following test are pyrophoric when mixed -- use extreme caution in handling.

- A. Pass a bottle of diethylzinc, a bottle of heptane, and an empty bottle with cap into Dri-Lab.
- B. Mix a small amount of each material together in the empty bottle, but be prepared to cover the bottle immediately if smoke is seen. For best results, hold a gloved hand behind the bottle: the white smoke will be better seen against the black background.
 - o If there is less than 5 ppm of oxygen within the Dri-Lab, the mixture will not emit smoke.
 - o If smoke is seen, a relatively high amount of oxygen exists. Cap bottle immediately.

Section 3
OPERATIONS

GENERAL

The instructions that follow are for basic operation of the Dri-Lab without a Dri-Train automatic recirculating system. Operating instructions for the combined Dri-Lab/Dri-Train are found in the Dri-Train manual.

ESTABLISHING AN INERT ATMOSPHERE

A good purge is required to establish an inert atmosphere. The purge described herein requires 200 to 250 ft³ of gas for a 25-ft³ box (this equals about 10 volume changes). For best results, use as pure a gas as is available.

- A. Install purge inlet and exhaust valves (user furnished) on two ports in back of the Dri-Lab (Figure 3-1).
- B. Connect gas supply to Dri-Lab inlet purge valve.

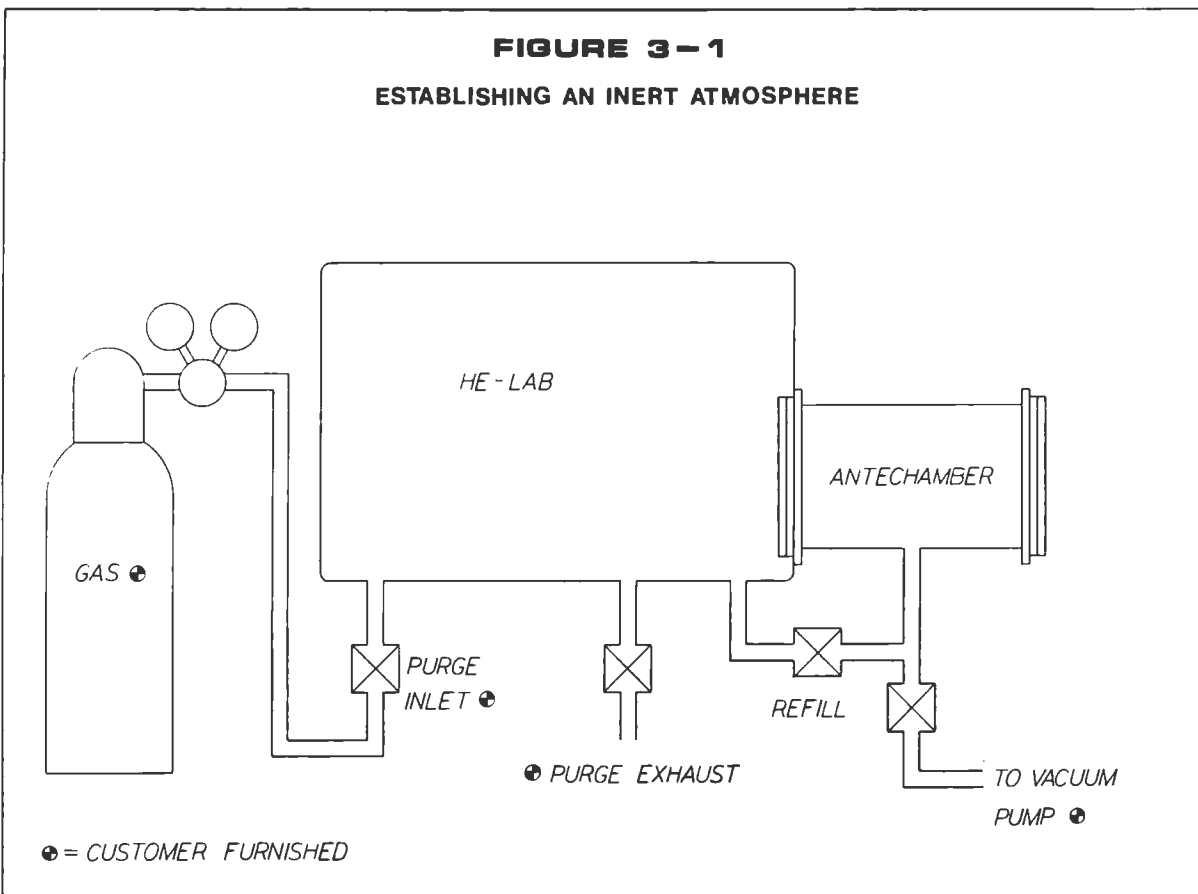

- C. Close antechamber inside door, refill valve, and evacuation valve.
- D. Open purge exhaust valve.
- E. Open purge inlet valve and begin gas flow. Keep the Dri-Lab pressure positive. The gloves must be extended to almost horizontal, but not ballooned.
- F. When purge is completed, close purge inlet valve and then the purge outlet valve before the gloves drop. Leave a positive pressure in the Dri-Lab.

ANTECHAMBER

Evacuate/Refill Procedure

Any time the antechamber is exposed to atmosphere, the following procedure must be used before opening the inside antechamber door to the glove box:

- A. Both antechamber doors must be closed.
- B. Refill valve must be closed.
- C. Open evacuation valve and evacuate to 50 microns (minimum).
- E. Close evacuation valve.
- F. Open refill valve.

Since the antechamber refills from the glove box, additional gas will be required to make up for the decrease in pressure in the glove box. Add gas via the glove box inlet valve to make up for this decrease in pressure.

GLOVE BOX

Be aware of the following items when using the Dri-Lab glove box:

- Watch the gloves during antechamber evacuation. If the gloves are drawn into the glove box, check the inside antechamber door and/or refill valve; either one may be open. Close the door and refill valve to the antechamber.
- Keep the antechamber doors and valves tightly closed when not in use.

- Never attempt to force the antechamber doors open.
- When opening the antechamber doors, back door off firmly against the bar before raising.
- Do not allow the glove box pressure to go negative. Refill gas into the glove box at a rate that maintains the same volume of gas as before the antechamber was filled.

PASSING MATERIALS IN/OUT OF DRI-LAB

Passing materials into and out of the Dri-Lab are explained in Figures 3-2 and 3-3, respectively.

FIGURE 3-2
PROCEDURE FOR PASSING MATERIALS INTO DRI-LAB

- STEP 1 - ARTICLE OUTSIDE A/C.
 - INSIDE DOOR CLOSED.
 - OUTSIDE DOOR OPENED.
 - A/C IS CONTAMINATED.
 - DRI-LAB HAS INERT ATMOSPHERE.

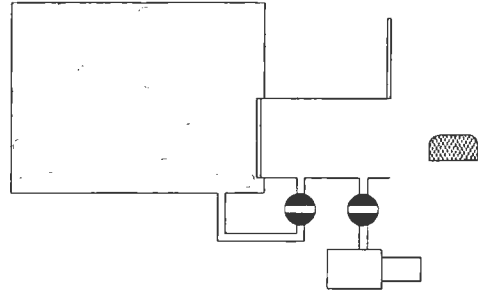

- STEP 2 - ARTICLE IS IN A/C.
 - BOTH DOORS ARE CLOSED.
 - A/C IS PARTIALLY EVACUATED.
 - DRI-LAB HAS INERT ATMOSPHERE.

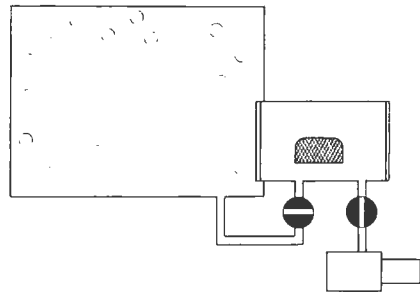

- STEP 3 - ARTICLE IS IN A/C.
 - A/C IS COMPLETELY EVACUATED.
 - DRI-LAB HAS INERT ATMOSPHERE.

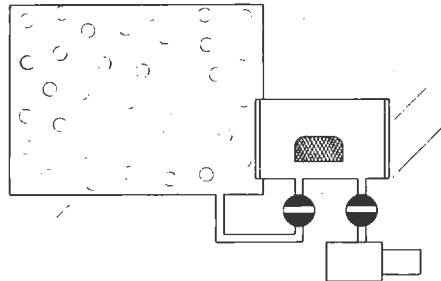

- STEP 4 - ARTICLE IS IN A/C.
 - BOTH DOORS STILL CLOSED.
 - A/C IS BACKFILLED WITH ATMOSPHERE FROM DRI-LAB.
 - DRI-LAB & A/C HAVE INERT ATMOSPHERE.

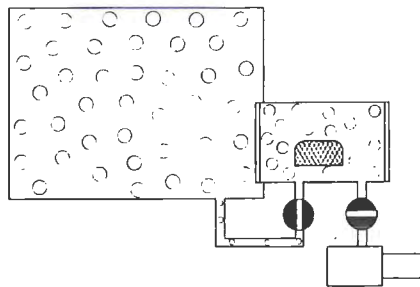

- STEP 5 - OUTSIDE DOOR CLOSED.
 - INSIDE DOOR OPENED.
 - ARTICLE MOVED INTO DRI-LAB.

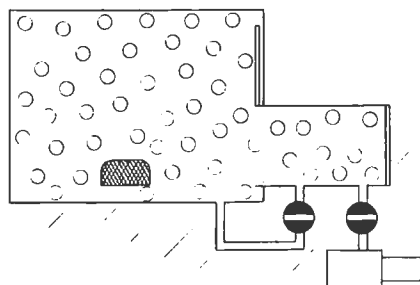

NOTES :



- 1 -  VALVE OPEN.
- 2 -  VALVE CLOSE.
- 3 - KEEP A/C DOORS CLOSED UNLESS IN USE.

FIGURE 3-3
PROCEDURE FOR PASSING MATERIALS OUT OF DRI-LAB



- STEP 1 - ARTICLE INSIDE DRI-LAB.
 - INSIDE DOOR CLOSED.
 - OUTSIDE DOOR OPENED.
 - A/C IS CONTAMINATED.
 - DRI-LAB HAS INERT ATMOSPHERE

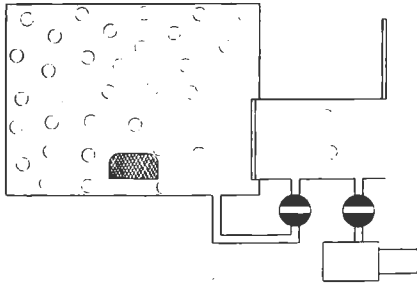
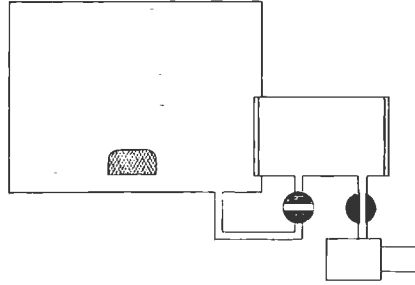

- STEP 2 - ARTICLE INSIDE DRI-LAB.
 - BOTH DOORS ARE CLOSED.
 - A/C IS PARTIALLY EVACUATED.
 - DRI-LAB HAS INERT ATMOSPHERE

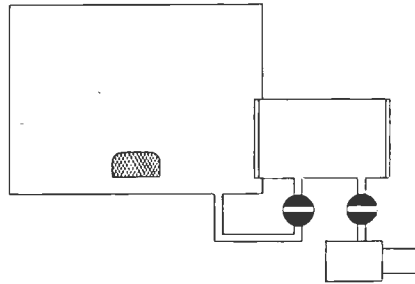

- STEP 3 - ARTICLE INSIDE DRI-LAB.
 - A/C IS COMPLETELY EVACUATED.
 - DRI-LAB HAS INERT ATMOSPHERE

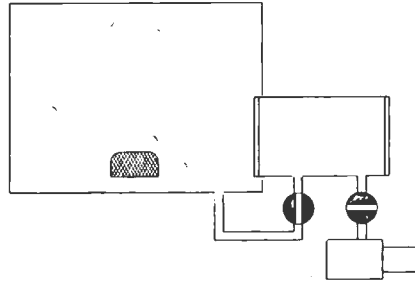

- STEP 4 - ARTICLE INSIDE DRI-LAB
 - BOTH DOORS STILL CLOSED.
 - ATMOSPHERE FROM DRI-LAB BACKFILLS A/C.
 - DRI-LAB & A/C HAVE INERT ATMOSPHERE.

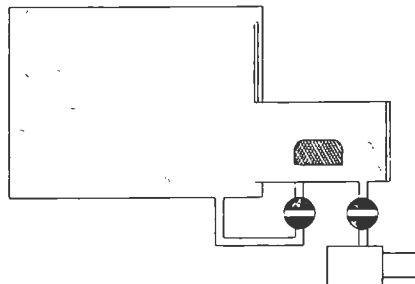

- STEP 5 - INSIDE DOOR OPENED.
 - ARTICLE MOVED INTO A/C.
 - DRI-LAB & A/C HAVE INERT ATMOSPHERE

- STEP 6 - INSIDE DOOR CLOSED.
 - OUTSIDE DOOR OPENED.
 - ARTICLE IS MOVED OUTSIDE A/C.

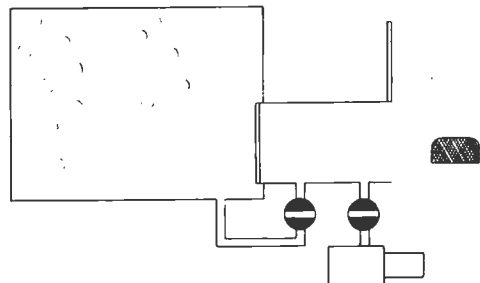

NOTES :

- 1 - VALVE OPEN.
- 2 - VALVE CLOSE.
- 3 - KEEP A/C DOORS CLOSE UNLESS IN USE.

Section 4

MAINTENANCE AND TROUBLESHOOTING

GENERAL

Maintenance of the HE-series Dri-Lab is uncomplicated due to relative simplicity of the unit's design and component selection. However, standard safe practices should always be observed during maintenance.

Periodic Maintenance

Visual inspection of Dri-Lab O-rings, gloves, and vacuum system should be performed to ensure tightness of glove box and proper operation of the vacuum system. (See also Section 2-5, Leak Test.)

Safety Glass Panels (Optional)

Refer to Safety Glass Windows in Appendix E for installation instructions and replacement procedures.

Lexan Panels

Clean panel with a clean cloth and either soap and water or a commercial glass cleaner.

CAUTION

Do not use abrasives such as steel wool, stiff paper towels, or abrasive cleaners to clean panels.

To replace window or metal panels:

- A. Remove 7/16-in. acorn nuts at frame and panel.
- B. Clean gasket, panel, and box and apply a light coat of vacuum grease to gasket. Replace worn or damaged gaskets.
- C. Replace panel and frame over the gasket onto the box studs, and install acorn nuts at 26 to 28 in.-lb torque.
- D. Leak check all joints.

Dri-Lab

Use mild soap and water to clean the outside painted surfaces. Dry the unit with compressed air. At recommended 3-mo intervals, all valves, fittings, lines, tubing, and connections should be inspected for general mechanical and electrical integrity.

Antechamber

Check the sealing O-rings periodically and replace when worn or damaged. Clean antechamber doors periodically with a mild solvent, and coat the sealing surfaces with a light coat of vacuum grease. If required, adjust antechamber door tension as follows:

- A. Close door and loosen jam nut at door clamp (Figure 4-1). Loosen nut 2.
- B. Open door and rotate door clockwise (increase tension) or counterclockwise (decrease tension).
- C. Close door to fully closed position - firm pressure should be required to close door.
- D. Tighten nut 2 and then jam nut.

Replacing Old Gloves

Gloves should be replaced at the first sign of deterioration. To replace old gloves with a minimum of Dri-Lab contamination:

- A. Seal glove port with internal glove port cover (optional equipment).
- B. Remove glove by reversing the procedure for installing gloves as outlined in Section 2-4.
- C. Install new glove as outlined in Section 2-4.
- D. Before installing clamp, purge glove as follows:
 - 1) Increase and maintain positive pressure in glove box at approximately 4-in. water column.
 - 2) Loosen glove port cover to allow glove to fill with inert gas from glove box.
 - 3) Once glove is pressurized, tighten glove port cover again.

Detailed Instruction For
Antechamber Door Adjustment

Door Tension

Tools required:

- 9/16 inch open/end/box wrench, 1 each.
- 1-1/2 inch thin open/end wrench, if adjusting Clamp.
(Bonney 1-1/2 inch open/end thin wrench #1248, 1 each)
- 3/4 inch open/end/box wrench, if adjusting Spring, 1 each.

!!NOTE!!

Before adjusting the door make sure that the opposing door is **closed**, to avoid accidental contamination of glove box atmosphere. If adjusting inside door, evacuate and refill Antechamber using your standard pump down time.

1.) Tension Door Adjustment:

- A)**Close door and loosen nut 2 (*J*) close to the door clamp (*F*). Never loosen nut 1 (*H*) (Figure 4-1).
- B)**Release door clamp (*F*), until door will turn.
- C)**Turn door (*C*) (clockwise CW to increase tension), (counterclockwise CCW to decrease tension).
- D)**Close door clamp (*F*) fully. Firm pressure should be required to close door. This may require several movements of the door (*C*) to increase or decrease the tension required to close the door.
- E)**Close door clamp (*F*) fully then tighten nut 2 (*J*).

2.) Adjusting / Replacing Door Clamp:

- A)**Close door, evacuate antechamber to 10 inches Hg.
- B)**Loosen nut 2 (*J*) and jam nut (*K*).
- C)**Release door clamp (*F*). Turn CCW allowing the door clamp handle to move freely.

Detailed Instruction For
Antechamber Door Adjustment

!!NOTE!!

Use a clamp on the end of the door bar (E) at the door boss close to the window. This will keep the door bar from flying up and back to the door stop, because of the balance weight (D) and no door for counter balance.

D)To replace door clamp (F), install jam nut (K) until it is fully seated against the door clamp shoulder.

E)Open the door clamp (F) fully then slowly turn CW until you have engaged the threads in the door bar (E). Now close the door clamp slowly to pick up the door screw (G) while turning the door clamp CW. Let the door handle move freely while turning. Turn the door handle until it is as close to the door bar (E) as possible. Now return the handle to the original position and tighten jam nut (K) against door bar.

F)Refill antechamber and go to Tension Adjustment on page one.

3.)Adjusting Counter Balance Spring (Dri-Labs 1989 and Newer)

A)Open door clamp (F). Do not raise door bar (E).

B)Place your 3/4 inch open end wrench on flats of the door boss spring holder located at the door hinge point. (Note the present location of the screw holding the end of the spring for a reference point).

C)Holding the 3/4 inch open end wrench with one hand, use your other hand, with the 9/16" box end wrench loosen the 9/16 inch bolt by turning it CCW.

D)Now you are ready to adjust the Counter Balance Spring. You turn the door boss spring holder with the 3/4 inch open end wrench so that the door bar (E) will stay balance and horizontal with the floor of the Dri-Lab. Tighten the 9/16 inch bolt before releasing pressure on the 3/4 inch wrench for each adjustment.

Dri-Lab-08/91

FIGURE 4-1
ANTECHAMBER DOOR ASSEMBLY

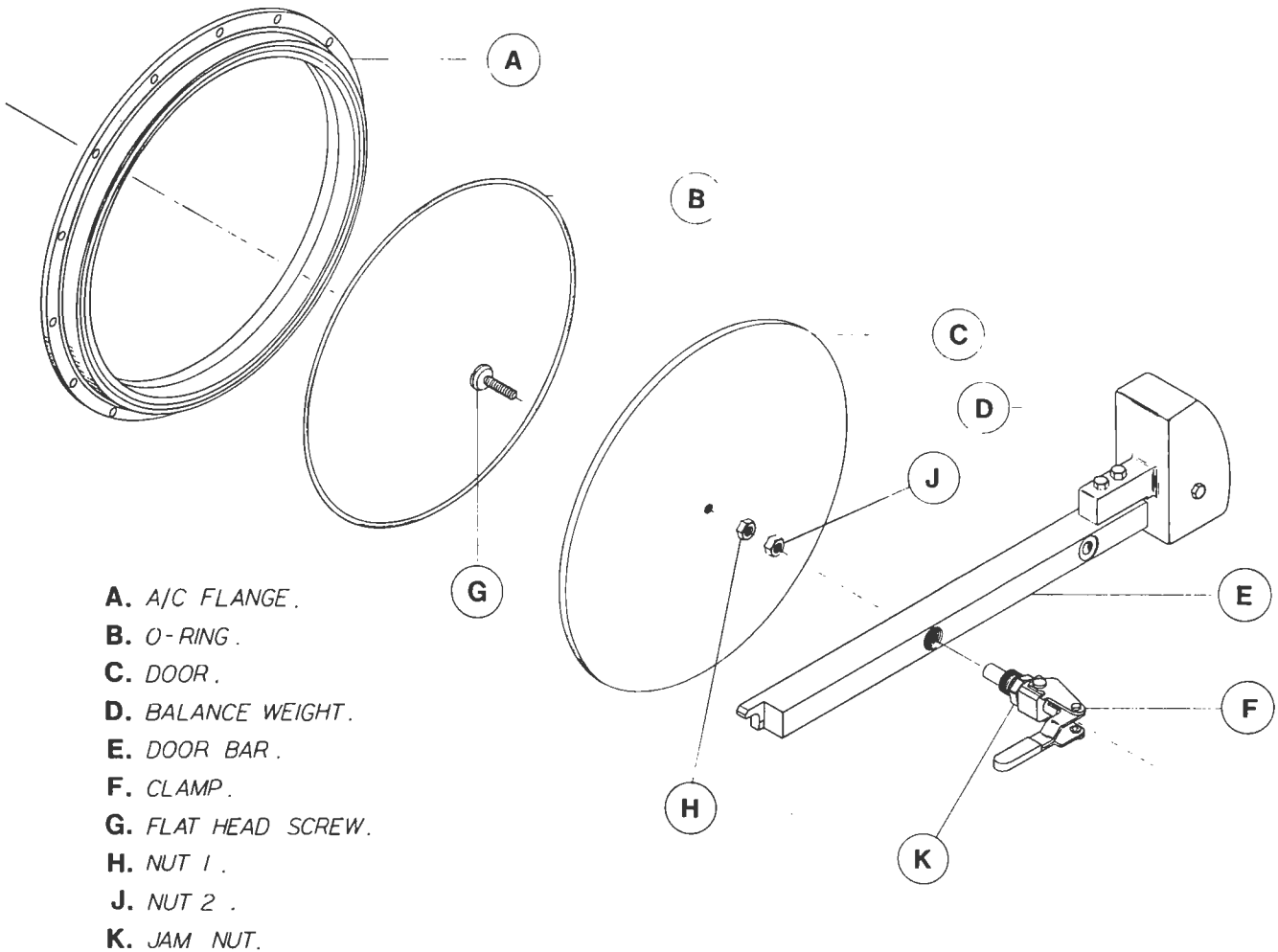

- 4) Roll glove slowly toward box, starting at fingers, intermittently releasing glove around glove port to allow pressure to release. Continue until glove has been rolled up to glove port.
 - 5) Repeat steps 1 to 4 approximately two or three times before removing glove port cover and placing it back in the glove box.
- E. Install clamp over O-ring.
- F. Remove internal glove port cover and check for leaks.

Accessories

For maintenance of purchased accessories, refer to accessory instruction sheets in Appendix E.

TROUBLESHOOTING

Failures in operating the Dri-Lab may occur in one or more of the following areas: a) glove box, b) vacuum system, or c) ante-chamber. Check these areas first. Table 4-1 provides additional information in locating and correcting problems.

Table 4-1
Troubleshooting Dri-Lab

Problem	Test	Solutions
I. Glove box does not hold pressure or unable to establish low oxygen levels (bad atmosphere).	<ul style="list-style-type: none"> ● Check leak test procedures for glove box. ● Visually inspect gloves for holes or damage; inspect purge exhaust valve. 	<ul style="list-style-type: none"> ● New gloves. ● Tighten loose connections into glove box. ● Clean or replace purge exhaust valve.

II. Pressure decreases in glove box when evacuating anti-chamber. <p style="text-align: center;"><u>or</u></p> Oxygen levels increased when opening outside anti-chamber door.	<ul style="list-style-type: none"> ● Dirty/damaged inside door O-ring. ● Defective anti-chamber refill valve - can be eliminated from problem by plugging hole inside Dri-Lab. 	<ul style="list-style-type: none"> ● Clean or replace valves/O-ring.

III. Atmosphere deteriorates inside glove box when inside anti-chamber door is opened and outside door is closed.	<ul style="list-style-type: none"> ● Dirty/damaged outside door O-ring. ● Insufficient tension on outside door clamp. 	<ul style="list-style-type: none"> ● Clean or replace O-ring. ● Increase tension of outside door clamp.

IV. Excessive pressure inside glove box.	<ul style="list-style-type: none"> ● Inspect purge inlet valve. ● Inspect purge exhaust valve for blockage. 	<ul style="list-style-type: none"> ● Clean or replace purge inlet valve. ● Clean or replace purge exhaust valve.

Section 5

PARTS AND ACCESSORIES**REPLACEMENT POLICY**

Vacuum/Atmospheres Company warrants all parts in the HE- and DL-series Dri-Labs. All parts or assemblies installed in these Dri-Labs, whether or not they are built by VAC, are warranted under the Warranty in Appendix C.

SPARE PARTS

VAC spare part numbers are listed in Tables D-1 and D-2 of Appendix D. To order spare or replacement parts, contact Vacuum/Atmospheres Company direct.

ACCESSORIES

Refer to Appendix E for instructions on those accessories provided with Dri-Lab.

APPENDIXES

Appendix A
Specifications And Dimensions

Specifications and dimensions are as outlined below. These details are standard and some may not apply to custom systems.

GLOVE BOX

Construction:

(HE-series) Modular structure with elastomer-gasketed end panels and full-view front window for ease of removal and replacement. Additional box modules may be added at any time. Antechamber may be moved to either end.

(DL-series) One-piece structure with elastomer-gasketed front window for ease of removal and replacement. All interior corners are 1/2-in. minimum radius; no seams, cracks, or crevices.

Material:

(HE-series) 3/16-in., Type 6061 brushed aluminum inside and textured paint outside, or 11-gauge, Type 304 stainless steel.

(DL-series) 12-gauge, Type 304 stainless steel inside and textured paint outside.

Window:

Scratch and chemically resistant, optically clear, 1/4-in. Lexan with high-impact resistance; or safety glass.

Appendix A (Cont'd)

Ports/Gloves:	One pair of 9-in. glove ports, 18 in. on center. No. 8B3032 butyl rubber gloves (optional) 15- or 30-mil. thick, ambidextrous or formed left and right hands.
Lighting: (HE-series)	Skylight panel, 26-1/2-in. long x 14-1/2-in. wide. Two 20 W, external fluorescent tubes in a separate housing on top of the glove box (optional). Light produces 60 foot-candles on glove box floor. Separate AC cord is provided.
(DL-series)	One 30 W, external fluorescent tube in a separate housing on top of full-view front panel (optional).
Electrical Outlets:	Typically two duplex, 115 V, 15 A outlets.
Feedthrough Ports:	<ul style="list-style-type: none">o Four 1/2-in. FPT couplingso Two 1-1/2-in. circulation portso One 1-in. FPT coupling for bubblero One 1/2-in. FPT coupling for hygrometer probeo One 1/4-in. FPT coupling.
Test & Certification:	No detectable leaks at +8 in. water column helium and sniffed with a helium mass spectrometer with a calibrated sensitivity of 3×10^{-10} std. cc/sec (the sniff probe sensitivity is less than 1×10^{-5} std. cc/sec).

Appendix A (Cont'd)

ANTECHAMBER

Construction: High-vacuum design, O-ring sealed doors and valves. TIG-welded structure.

Material:

(HE-series) 1/8-in., Type 6061 aluminum or 12-gauge, Type 304 stainless steel, textured paint on outside only.

(DL-series) 12-gauge, Type 304 stainless steel, textured paint on outside only.

Vacuum Capability: One micron (1×10^{-3} torr).

Size: 15-in. diameter x 24-in. long.

Doors: Single, center-clamped, O-ring sealed, counterbalanced vertical action.

Gauge: 2-1/2-in. compound Bourdon tube, dial-type.

Tray: 23-in. long x 12-in. wide extending 11 in. beyond each end, mounted on ball bearing slide.

Connections: 1-in. evacuation valve, 1/4-in. refill valve.

Test &

Certification: No detectable leaks at full vacuum with helium mass spectrometer calibrated at 3×10^{-10} std. cc/sec.

Appendix A (Cont'd)

STAND

Construction: Table top stand with removable legs, or tubular frame for bolting on Dri-Lab.

Material: Mild steel.

Appendix B
Special Schematics or Diagrams

FIGURE B-2
SCHEMATIC DIAGRAM OF JUNCTION BOX

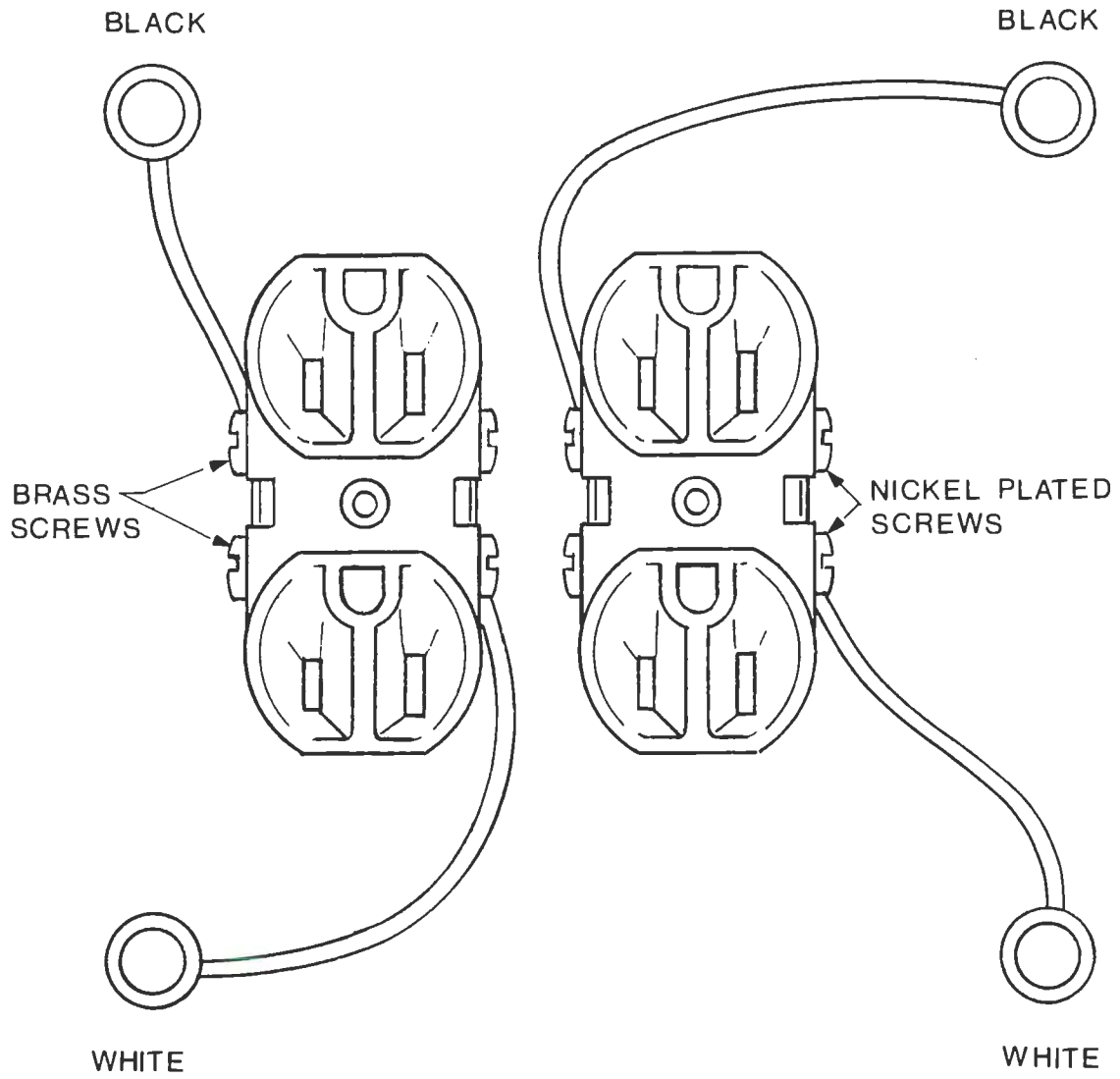

Appendix C
Warranty

This unit is warranted to be free from defect in factory material and workmanship for a period of 1 year from date of purchase, subject to normal wear, and freedom from undue abuse during handling and operation.

This warranty applies only to new equipment that, after shipment from the factory, has not been altered or treated in any manner whatsoever, and does not extend to trade accessories operated with VAC's own equipment.

VAC warrants that it will repair or furnish, FOB its factory, a replacement provided a part is found to have been defective at the time it was received and the defective part is returned to the factory, charges prepaid.

This warranty is the only warranty expressed, implied, or statutory upon which said equipment is sold. All other damages and warranties, statutory and otherwise, being hereby expressly waived by purchaser.

Components purchased from other manufacturers and included in the unit are subject to warranties as offered by the manufacturer of said components; of these components, certain expendable items are not covered; others are warranted for 90 days; others are warranted for 1 year.

Appendix D
Spare Part Listings

Table D-1. Spare Parts List (HE-series)

Item	Description	Part No.	Qty.
1	Lexan Front Panel	08651	1
2	1/2" Safety Glass Front Panel	013545	1
3	Front Panel Gasket (all)	08698	1
4	End Panel Gasket (HE-43/553)	08699	1
5	End Panel Gasket (HE-243/453-2)	08700	1
6	End Panel Gasket (HE-453-6)	08615	1
7	Skylight Gasket (all)	08695	1
8	O-ring Antechamber 15" dia.	2633	2
9	O-ring over glove	2631	1
10	O-ring Glove Port (Lexan)	2744	1
11	Gasket Glove Port (glass)	013921	1
12	O-ring Inside Door Boss	2635	1
13	1/4" Antechamber Refill Valve	2534	1
14	1" Antechamber Evacuation Valve	2743	1
15	1-1/2" Circulation Valve	7416	1
16	Gauge, Vacuum/Pressure (antechbr.)	2600-2	1
17	30 mil Butyl Rubber Glove 9-3/4" - Formed L & R	8B3032-L&R	1 pr
	Ambidextrous	8B3032-A	1 pr
18	15 mil Butyl Rubber Glove 9-3/4" - Formed L & R	8B1532-L&R	1 pr
	Ambidextrous	8B1532-A	1 pr
19	Dri-Lab Filter Replacement Cartridge	1211	2

Appendix D (Cont'd)

Table D-2. Spare Parts List (DL-series)

Item	Description	Part No.	Qty.
1	Lexan Front Panel (DLX)	08651	1
2	Lexan Front Panel (DL)	013349	1
3	1/2" Safety Glass Front Panel (DLX)	013545	1
4	1/2" Safety Glass Front Panel (DL)	011461-03	1
5	Front Panel Gasket (DLX)	08698	1
6	Front Panel Gasket (DL)	013350	1
7	O-ring Antechamber 15" dia.	2633	2
8	O-ring over gloves	2631	1
9	O-ring Glove Port (Lexan)	2744	1
10	Gasket Glove Port (glass)	013921	1
11	O-ring Inside Door Boss	2639	1
12	1/4" Antechamber Refill Valve	2534	1
13	1" Antechamber Evacuation Valve	2743	1
14	1-1/2" Circulation Valve	7416	2
15	Gauge, Vacuum/Pressure (antechbr.)	2600	1
16	30 mil Butyl Rubber Glove 9-3/4" - Formed L & R	8B3032-L&R	1 pr
	Ambidextrous	8B3032-A	1 pr
17	15 mil Butyl Rubber Glove 9-3/4" - Formed L & R	8B1532-L&R	1 pr
	Ambidextrous	8B1532-A	1 pr
18	Dri-Lab Filter Replacement Cartridge	1211	2

Index

- Aligning Dri-Lab, 2-1
- Adjusting gloves, 2-2
- Accessories, 4-4, 5-1, E-1
- Acorn nuts, 2-2, 4-1
- Antechamber
 - evacuate procedure, 3-2
 - door assembly, 4-3
 - refill procedure, 3-2
 - specifications, A-3
 - maintenance, 4-2
- Appendixes, A 1 - E-1
- Application (Dri-Lab), 1-1
- Area (working), 1-1, A-1
- Argon gas, 1 1
- Assembly
 - Dri-Lab, 1-2
- Atmosphere (see Establishing Inert Atmosphere)
- Auxilliary feedthrough
 - ports, 1-2
- Balance weight, 4-3
- Bead
 - glove, 2-2 - 2 3
 - welded, 2-6
- Blockage
 - valve, 4-5
- Box
 - studs, 4-1
 - pressure (see Glove Box)
- Compound gage, 1-2
- Connections
 - gas, 1-1 - 1-2, 3-1
 - electrical, 1-1 - 1 2,
 - water, 1 1 - 1-2,
- Contents, ii
- Corrosive materials, 2 5
- Clamp
 - stainless steel, 2-3
- Cleaners, 4-1
- Cleaning (see Maintenance)
- Diethylzinc test, 2-7
- Dimensions (see Specifications)
- Door
 - assembly (see Antechamber)
 - tension, 4-2
- Electric lightbulb test, 2-6
- Electrical
 - schematic diagram, B-1
 - utility requirements, 2-1
- Establishing inert
 - atmosphere, 3-1 - 3-2
- Evacuate procedure, 3-2
- Evacuation
 - valve, 1-2, 2-2, 2-4
- Exhaust valve, 3-1
- Functional description, 1-1

Index (Cont'd)

- Gas
 - inert, 1 1, 2 1
 - supply, 2-2, 3-1
- General
 - installation, 2-1
 - maintenance, 4-1
 - operation, 3 1
- Gloves
 - installation, 2 2 - 2 3
 - leaks, 2-5
 - replacement, 4-2
- Glove box
 - description, 1-1
 - maintenance (see Maintenance)
 - operation, 3 2
 - user information, 3-2
- Glove port, 1-2, 2-1

- Halogen leak detection, 2-4
- Helium leak detection, 2-4
- Hose
 - vacuum, 2-2
- Inert atmosphere (see Establishing Inert Atmosphere)
- Installation, 2 1 - 2-7
- Introduction, v
- In/Out procedures (see Passing Materials In/Out)

- Jam nut, 4-2 - 4-3
- Junction box, 1-2, 2-1, 2-6, B-1

- Leak testing, 2-2
- Lexan panel
 - maintenance, 4-1
- List of Figures, iv
- List of Tables, iv

- Maintenance, 4-1 - 4-4
- Moisture testing, 2-6

- Operation
 - antechamber, 3-2
 - general, 3-1
 - glove box, 3-2
 - passing materials, 3-4 - 3-5
- Overview, 1-1
- Oxygen testing, 2-6
- O-ring
 - antechamber, 4-3
 - glove box, 2-2 - 2-3

- Panels
 - Lexan, 4-1
 - safety glass, 4-1
- Parts, 5-1
- Passing materials in/out, 3-4 - 3-5
- Periodic maintenance, 4-1

- Refill procedure, 3-2
- Refill valve, 1-2, 3-2
- Replacement policy, 5-1

Index (Cont'd)

Replacing

- gloves (see Gloves)
- panels, 4-1
- windows, 4-1

Schematic diagram, B-1

Skylight, 1-1 - 1-2, 2-1

Sliding tray, 1-1

Spare parts, 5-1

Spare parts listing, D-1 - D-2

Specifications, A-1 - A-2

Testing

- leak, 2-2
- moisture, 2-6
- oxygen, 2-6

Titanium tetrachloride

test, 2-7

Troubleshooting, 4-1 - 4-5

Tubing, 2-1

Utility requirements, 2-1

Vacuum

- line, 2-2
- pump, 2-1

Valves

- inlet/exhaust, 3-1
- (see Evacuation or Refill)

Warranty, C-1

**Appendix E`
Accessories**



4652 West Rosecrans Avenue
P.O. Box 1043
Hawthorne, CA 90250-6896
(310) 644-0255
Fax: (310) 970-0980

**IMPORTANT
SERVICE BULLETIN**

READ CAREFULLY

Dear Customer:

Vacuum/Atmospheres Company wishes to continue to provide you with the very best service possible. Recent changes in environmental laws now require some changes in our "returned goods" policies.

Before any item can be returned for repair or replacement, a **Returned Goods Authorization Number (RGA)** must be obtained from the VAC Sales Department. Be prepared to provide information about the chemicals which the item to be returned has been exposed. VAC Sales may be reached at:

Telephone: (310) 644-0255 (8:00am - 5:00pm PST)

Fax: (310) 970-0980 (24 Hours)

The **RGA** Number must be shown on the packing slip accompanying the item and be marked on the outside of the shipping container. Items without a **RGA** Number will not be accepted for repair or replacement.

Material Safety Data Sheets (MSDS) for each chemical to which the returned item has been exposed, must accompany the item being returned.

Any item being returned must be cleaned for safe handling before being shipped to VAC. Vacuum Pumps must be drained of all pump oil before being returned. Items that have not been cleaned and made safe for handling **WILL NOT BE ACCEPTED** for repair or replacement.

If you have any questions, please call or fax VAC at the numbers listed above.

```

#####
##           ##
## #####   ##
## #####   ##
##           ##
## #####   ##

```

Panametrics, Inc.
221 Crescent St.
Waltham, MA 02154-3497
Phone: 781-899-2719 / Fax: 781-894-8582

Moisture Sensor Calibration Data Sheet for use with AMX 1

Probe Serial Number 13128-GL
Calibrated on October 01, 1999
Sales Order Number P 152650-4

AMX 1 SN 2055

Point Number	Dew Point (Deg C)	Output Signal (mA)	MH Reading (M)	Dew Point (Deg F)
0	-80	4.00	0.5953	-112
1	-70	5.60	0.6240	-94
2	-60	7.20	0.6638	-76
3	-50	8.80	0.7082	-58
4	-40	10.40	0.7735	-40
5	-30	12.00	0.8735	-22
6	-20	13.60	1.058	-4
7	-10	15.20	1.319	14
8	0	16.80	1.758	32
9	10	18.40	2.632	50
10	20	20.00	3.957	68

 ##
 ## #####
 ## #####
 ##
 ## #####

Panametrics, Inc.
 221 Crescent St.
 Waltham, MA 02154-3497

Phone: 781-899-2719 / Fax: 781-894-8582

Moisture Sensor Calibration Data Sheet for use with AMX 1

Probe Serial Number 13128-GL
 Calibrated on October 01, 1999
 Sales Order Number P 152650-4

AMX 1 SN 2055

Point Number	Dew Point (Deg C)	Output Signal (mA)	MH Reading (M)	Dew Point (Deg F)
0	-80	4.00	0.5953	-112
1	-70	5.60	0.6240	-94
2	-60	7.20	0.6638	-76
3	-50	8.80	0.7082	-58
4	-40	10.40	0.7735	-40
5	-30	12.00	0.8735	-22
6	-20	13.60	1.058	-4
7	-10	15.20	1.319	14
8	0	16.80	1.758	32
9	10	18.40	2.632	50
10	20	20.00	3.957	68

Glove Box Static Eliminator

- DC Ionization
- Replaceable Thoriated Tungsten Emitters
- Controllable Pulse Rates
- Controllable Polarity Balance
- Grounded Metal Housing
- Current Limited Emitters
- Ion Coverage up to 36"

Features

The work station ionizer is designed to effectively eliminate localized static charges which exist in the glove box or lab work area.

Pulse rate and ion balance controls allow for effective calibration and adjustment to give optimum balance and output.

Replaceable Thoriated Tungsten emitter points ensure long life and reliability.

Compact design utilizes minimum amount of valuable glove box or bench counter space.



Specifications

- Current Limiting:** To 15 microamps
- Output Voltage:** 15kVDC
- Input Voltage:** 120 VAC/220 VAC
- Electrode Material:** Thoriated Tungsten
(replaceable)
- Pulse Frequency:** Adjustable from 1 pulse per sec. to 5 pulses/sec.
- Ozone:** less than 0.1 ppm
- Housing:** Grounded metal case
- Power:** On/Off Switch
- Power Cord:** 3-wire UL approved
- Size:** 4.25" W x 5.0"H x 2.5"D
- Weight:** 2lbs.

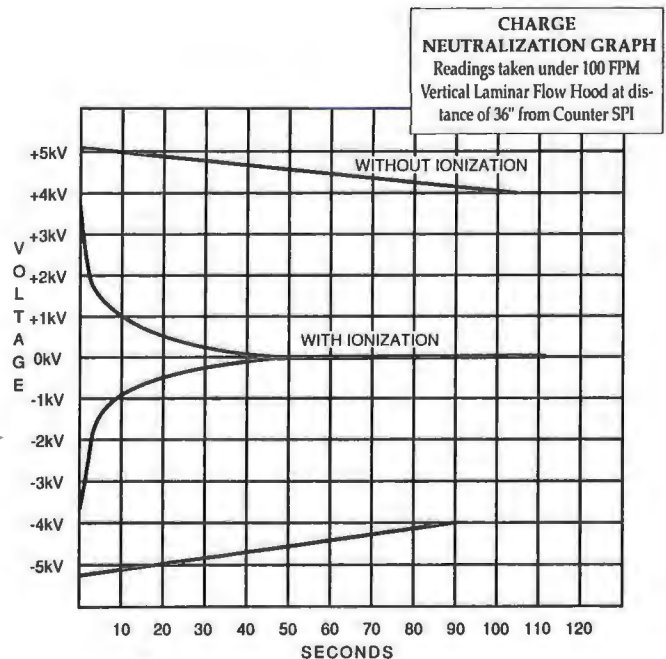

MB-150-M Glove Box System

Catalyst usually last 5-10 years and consists of a copper oxide on alumina catalyst and Molecular Sieves

Catalyst: Need 4.5kg of 14x20 particle size (can also use 8x14)

MBraun: FC-01 \$425

Englehard: Cu-0226

Purchase catalyst from Englehard Corp

Molecular Sieves: Need 12 lbs of 13X Beads (not pellets!). We used 8-12 mesh, but not sure if that's going to make a difference.

Purchase sieves from Aldrich or wherever.

Accessories:

1. Spare Gloves
2. Static Eliminator Part# ACC-11 \$460
3. Internal Glove Port Cover Part# GP-03
4. PLC H₂O Analyzer
5. PLC O₂ Analyzer

Regeneration:

1. Purge with Regen gas for 345 mins
 - a. R_g open
 - b. E open
2. Evacuate for 60 mins
 - a. R_g closed
 - b. E closed
 - c. R_v open
3. Cool and cycle for 660 mins
 - a. R_v closes, K opens
 - b. Cycles through the opening and closing.

Englehard Corp (Sales)
120 Pine St.
P.O. Box 4017
Elyria, Ohio 44035
1-800-321-2747
Contact: Judy Leach

Englehard Corp (Manufacturer)
1 West Central Avenue
E. Newark, NJ 07024

MBraun
14 Marin Way
Stratham, NH 03885
1-603-773-9333